

# nEXT TURBOMOLECULAR PUMPS

 **EDWARDS**





## EDWARDS THE PARTNER OF CHOICE

**Edwards is a world leader in the design, technology and manufacture of vacuum pumps, with over 100 years' history and more than 80 years' manufacturing experience.**

We believe in delivering results that bring value to our customers by using our breadth of industry experience to identify and apply solutions to your problems. Using the most innovative and up-to-date modelling techniques and know-how, we can optimise the pumping configuration to achieve the maximum performance in the most reliable and cost-effective way.



# CONTENTS

INNOVATION  
AND RELIABILITY | 04

PERFORMANCE  
YOU CAN RELY ON | 06

nEXT55 AND nEXT85  
TURBOMOLECULAR PUMP | 08

nEXT240, nEXT300, nEXT400  
TURBOMOLECULAR PUMP | 11

nEXT730, nEXT930, nEXT1230  
TURBOMOLECULAR PUMP | 14

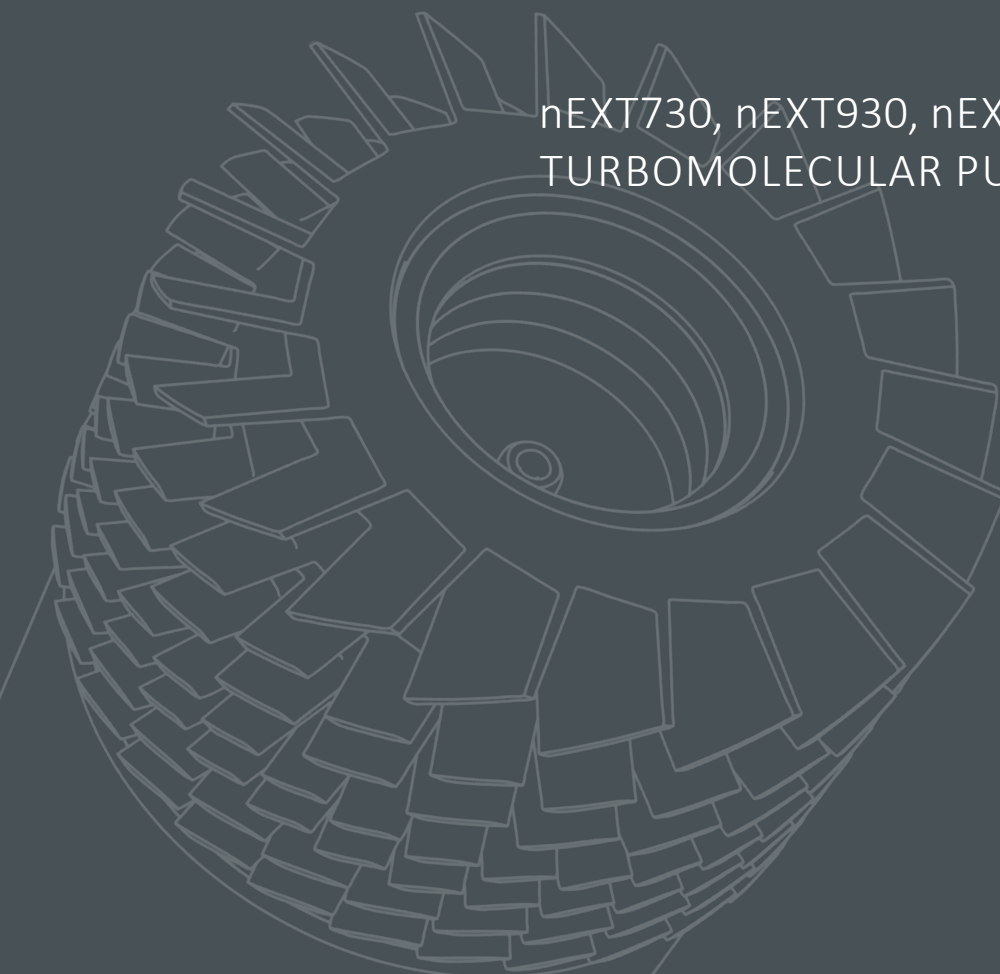

# INNOVATION AND RELIABILITY

Edwards nEXT is the ultimate experience in turbomolecular pumps

nEXT turbomolecular pumps are built on decades of experience and are drawing from our tried and trusted EXT and STP ranges. nEXT pumps offer superior performance, reliability and end user serviceability, setting the benchmark for scientific turbomolecular pumps.

## Superior performance

Exceptional pumping speeds and compression ratios

## Proven reliability for peace of mind

Huge install base of turbo pumps

## Flexible solutions

Bespoke design service available

## Ease of use

Integrated intelligent controls

## Extended lifetime and low cost of ownership

Fully end user serviceable

## Large variety of standard variants

Enhanced customer choice



nEXT55



nEXT85



nEXT240



nEXT300



nEXT400



nEXT730



nEXT930



nEXT1230

# APPLICATIONS

	nEXT55	nEXT85	nEXT240	nEXT300	nEXT400	nEXT730	nEXT930	nEXT1230
<b>Research &amp; Development</b>								
Chamber evacuation, coating systems, turbomolecular pump systems	✓	✓	✓	✓	✓	✓	✓	✓
<b>High Energy Physics</b>								
Beam Lines, accelerators, mobile pump carts, turbomolecular pump backing, laser evacuation, medical systems	✓	✓	✓	✓	✓	✓	✓	✓
<b>Mass Spectrometry</b>								
GCMS, LCMS, ICPMS, MALDI, inorganic MS, RGA, surface science, leak detectors	✓	✓	✓	✓	✓	✓		
<b>Electron Microscopy</b>								
TEM, SEM, EPMA, SPM sample prep benches	✓	✓	✓	✓	✓			
<b>Industrial</b>								
Glove boxes, coating systems, XRD/XRF systems, Leak testing, energy, furnaces, medical technologies	✓	✓	✓	✓	✓	✓	✓	✓

You can be assured Edwards has the application expertise and vacuum solution to meet your needs.

# ADVANCED TECHNOLOGY

nEXT has been designed to combine all the latest technological advances in turbomolecular pumps with some new thinking in design for manufacture, delivering a truly class leading product.

The nEXT platform brings a high level of modularity to offer maximum flexibility for customer application and requirements. Each pump is available in different internal configurations to offer differing functionality and performance.

Our nEXT pumps come in different variants "D" Duplex comes with both turbomolecular and drag stages for improved tolerance to higher backing line pressures. The "D" variants offer superior pumping speed and compression across all gas species. Triplex "T" variants feature turbomolecular, drag and Edwards unique regenerative pumping stages for the ultimate in compression ratio and boost technology for unique vacuum system rationalisation.

The "H" variant has been physically tuned to offer an improvement where an application has focus on light gas compression.

nEXT is available in eight models with a range of inlet flange sizes

		NW40	DN63 ISO-K	DN63-ISO CF	DN100 ISO-K	DN100 ISO CF	DN160 ISO-K	DN160 ISO CF	DN200 ISO-K	DN200 ISO CF	DN200 ISO-F
nEXT55D		x*	x	x	x*						
nEXT85D	nEXT85H	x	x	x	x						
nEXT240D	nEXT240T				x	x					
nEXT300D	nEXT300T				x	x					
nEXT400D	nEXT400T						x	x			
nEXT730D							x	x	x	x	
nEXT930D									x	x	
nEXT1230H									x	x	x

\*Available by special order

# PERFORMANCE YOU CAN RELY ON

The compact design of nEXT allows for close pitch positioning in multiple pump installations. Offering superior performance in a smaller space envelope. Compatible with Edwards TIC and TAG controllers.

Multiple drag stages for higher compression ratios and greater backing pressure tolerance

Direct temperature measurements within the pump enables wider operating envelope (nEXT55-nEXT85)

Third regenerative stage enables boost port options and higher compression (nEXT240, 300, 400)

Patented bearing suspension system minimises noise and vibration transmitted to vacuum (nEXT240, 300, 400)

User replaceable oil cartridge for a speedy interim service and bearing cartridge for a quick low cost scheduled overhaul (nEXT55-400)

Purge port for safe operation of pump with specialised gases

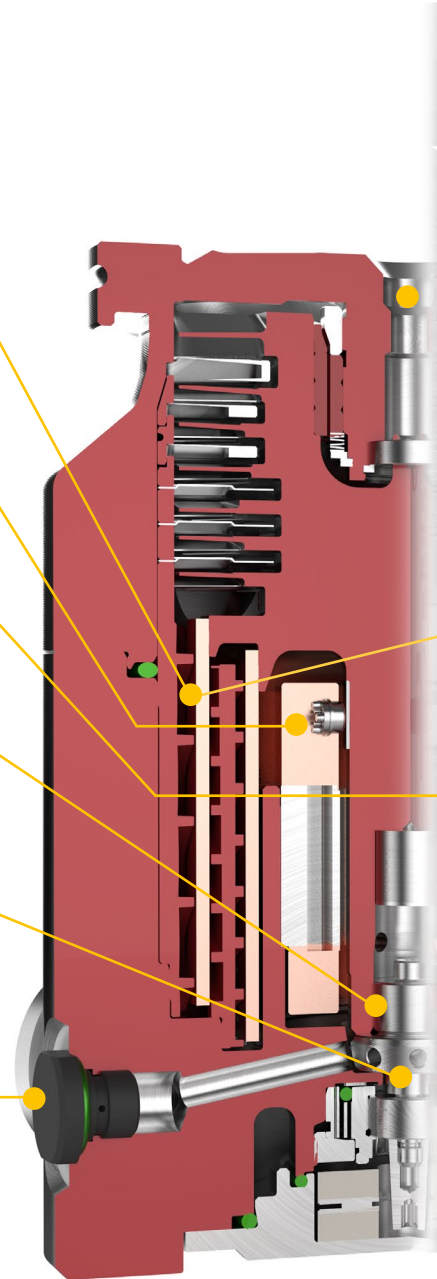

nEXT85 turbomolecular pump sectional view

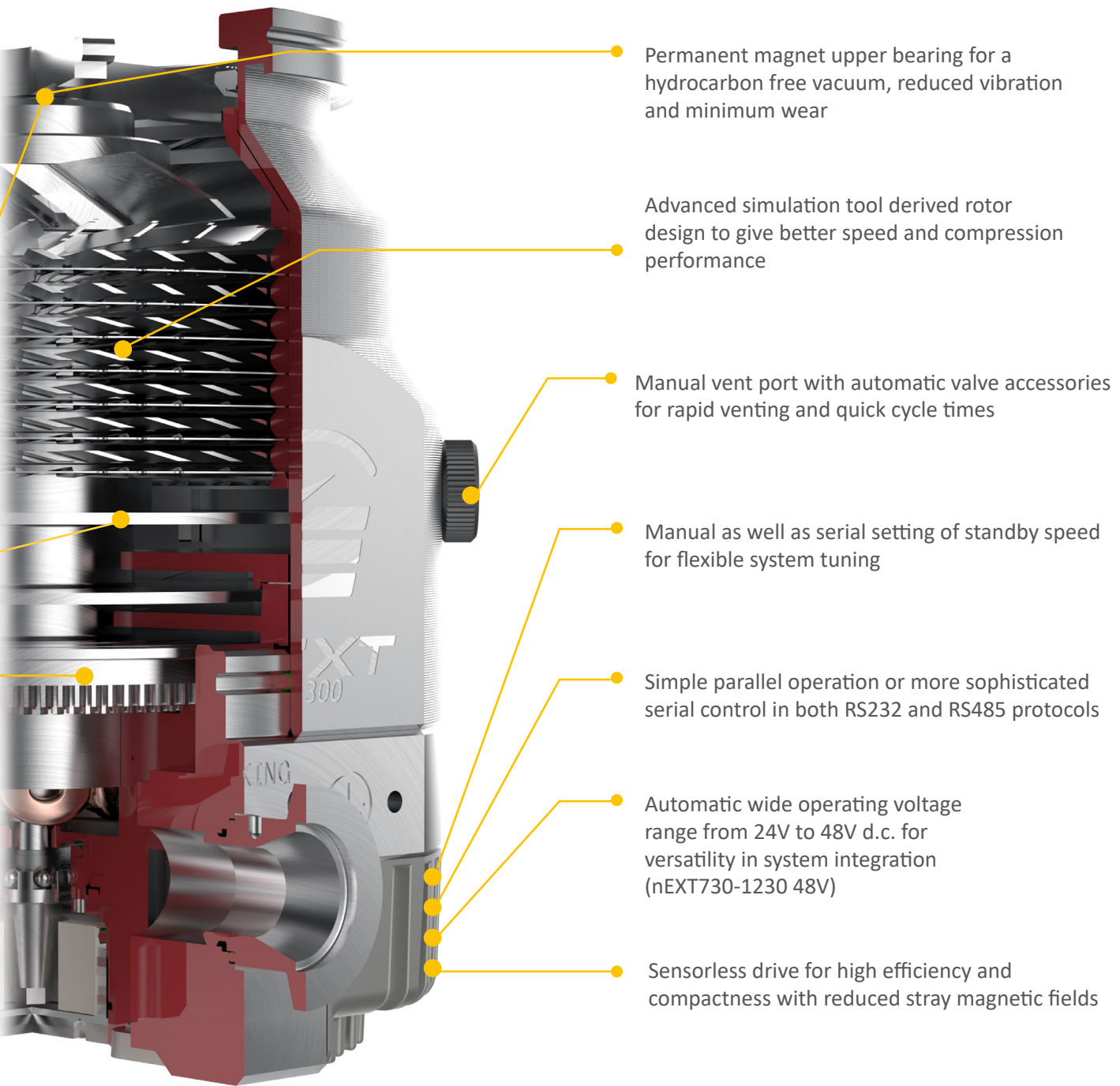

Permanent magnet upper bearing for a hydrocarbon free vacuum, reduced vibration and minimum wear

Advanced simulation tool derived rotor design to give better speed and compression performance

Manual vent port with automatic valve accessories for rapid venting and quick cycle times

Manual as well as serial setting of standby speed for flexible system tuning

Simple parallel operation or more sophisticated serial control in both RS232 and RS485 protocols

Automatic wide operating voltage range from 24V to 48V d.c. for versatility in system integration (nEXT730-1230 48V)

Sensorless drive for high efficiency and compactness with reduced stray magnetic fields

nEXT300 turbomolecular pump sectional view

# nEXT55 AND nEXT85 TURBOMOLECULAR PUMP

---

The nEXT55 and nEXT85 are the most compact pumps of the nEXT range with a significantly reduced height and improved performance in a smaller package. These pumps offer pumping speeds of 55 l/s and 85 l/s for nitrogen, they provide a high pumping density, greater than other pumps in its class, with almost double the pumping speed of similar sized turbo pumps.

The rotor has been designed to optimise pump performance and achieve both higher speeds and higher compression while maintaining high levels of reliability and low risk to adoptors. As with all the pumps in the nEXT range field maintenance is only required every 4 years of operation, and this including replacement of the bearing can be performed by the end user.

nEXT55 and nEXT85 bring with them the benefits in flexibility with comprehensive communication and control options available, as well as a full set of accessories, the ideal choice in deployable instruments or portable applications where a compact footprint or lower weight are key factors.





## TECHNICAL SPECIFICATIONS

		nEXT55		nEXT85	
Inlet flange		DN63 ISO-K or DN63 CF	NW40	DN63 ISO-K or DN63 CF	DN100 ISO-K
Inlet pumping speed $l s^{-1}$	N <sub>2</sub>	55	47	84	86
	Ar	55	44	80	84
	He	41	61	78	80/78 (D/H)
	H <sub>2</sub>	27	49/44 (D/H)	60/54 (D/H)	60/54 (D/H)
Compression ratio (D)	N <sub>2</sub> /Ar	>1 x 10 <sup>11</sup>			
	He	6.9 x 10 <sup>5</sup>	8 x 10 <sup>6</sup>		
	H <sub>2</sub>	2.9 x 10 <sup>4</sup>	2 x 10 <sup>5</sup>		
Compression ratio (T/H)	N <sub>2</sub> /Ar	NA	>1 x 10 <sup>11</sup>		
	He	NA	2 x 10 <sup>7</sup>		
	H <sub>2</sub>	NA	5 x 10 <sup>5</sup>		
Backing/interstage/boost ports		NW16			
Vent/purge port		1/8" BSPP			
Critical backing pressure (D/H)	mbar	18			
Critical backing pressure (T)	mbar	NA			
Bake out water cooled/forced air cooled max.	°C	120/115°			
Recommended backing pump*		nXDS6i			
Normal rotational speed (rpm)		90,000			
Start time to 90% speed (sec) D/H (T)		90			
Mass (kg) D/H (T)	ISO	2.47	2.9	3.0	3.2
	CF	3.5		4.4	

\*A smaller backing pump may be used depending on application.

# DIMENSIONS

## nEXT55

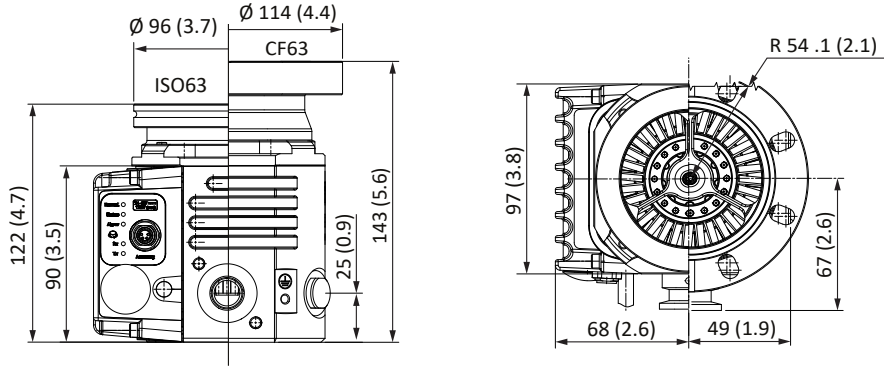

## nEXT85

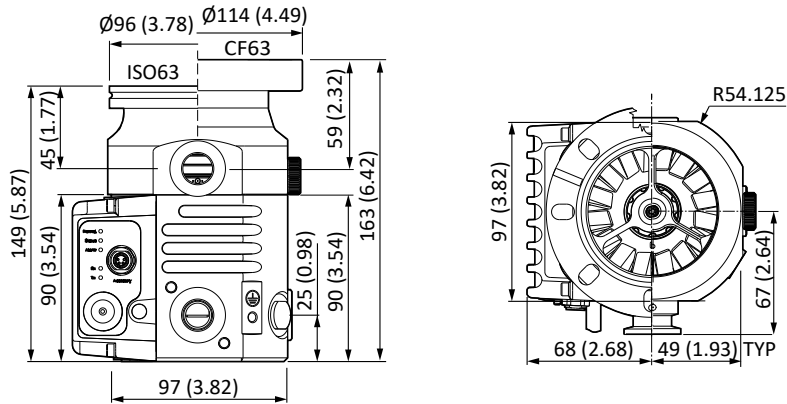

# PERFORMANCE

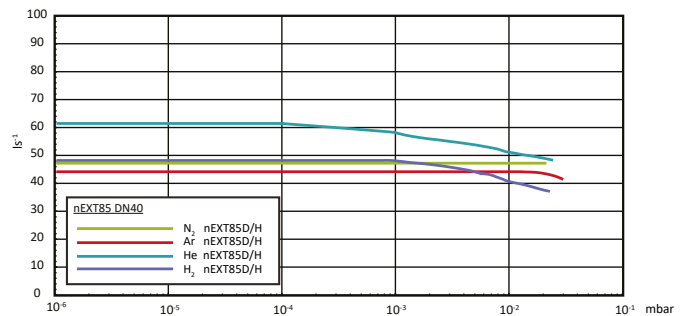
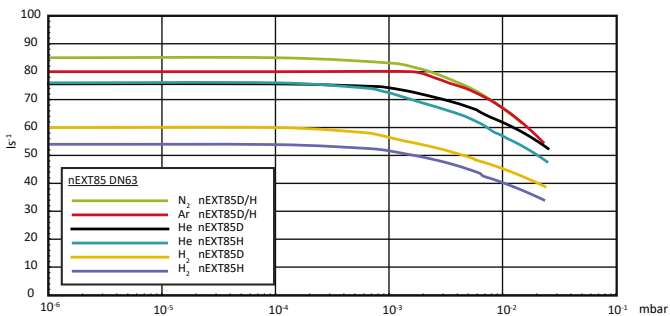
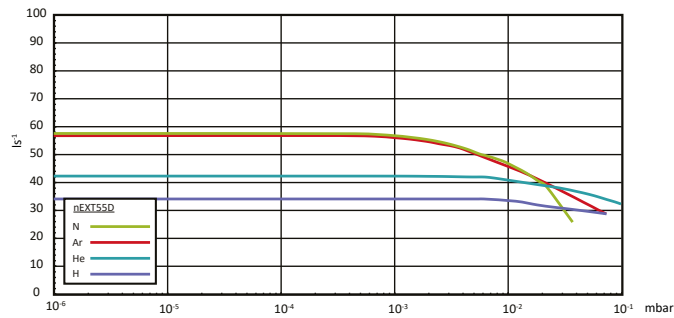

# nEXT240, nEXT300, nEXT400 TURBOMOLECULAR PUMP

The innovative nEXT240, nEXT300 and nEXT400 pumps, have been designed to provide high vacuum performance in a compact size.

The range offers a wide variety of sizes and variants giving OEMs and end users a greater choice and the flexibility to tailor the most appropriate vacuum solution to meet their individual needs.

Each is available in two variants: the D-Type combines turbo and drag stages; and the T-Type adds Edwards unique fluid dynamic stages and the option of additional booster ports for increased system rationalisation. See Boost technology custom interface splitflow variants are also available in three sizes for further vacuum system optimisation.

The pumps feature a field replaceable oil cartridge and bearing assembly and the user is notified as to when service intervention is required. This enables easy maintenance as users can carry out servicing in-house, which reduces the cost of ownership.

The efficient pumps have low power consumption and also feature a standby mode, which allow users to make further energy savings. nEXT240-300-400 pumps have extra low vibration and low magnetic field signature variants for sensitive electron microscope applications.

The compact design means the pumps fit together neatly in high product density applications. They are easy to configure and have an intelligent control interface accepting a 24 to 48Vdc input power supply voltage range and can be controlled using a simple parallel control or serial communications in both RS232 or RS485 formats.



# BOOST TECHNOLOGY

For our Analytical Instrument Customers the "T" variants of nEXT240,300,400 employ a unique regenerative pumping stage which can be used to 'boost' the performance of the backing pump. This offers a much simplified vacuum solution with greatly improved pumping speeds and system power reduction. The examples below shows how boost can be used to either reduce the size of the primary pump or increase the gas flow into the instrument on a differentially pumped system. It also illustrates how the number of turbo pumps required can be reduced from two discrete pumps to a single splitflow pump with two inlets to achieve the same vacuum performance.

Customers in general laboratory and R&D applications will also benefit from the improved compression achieved with the "T" variant. To take maximum advantage of boost technology, please contact Edwards.

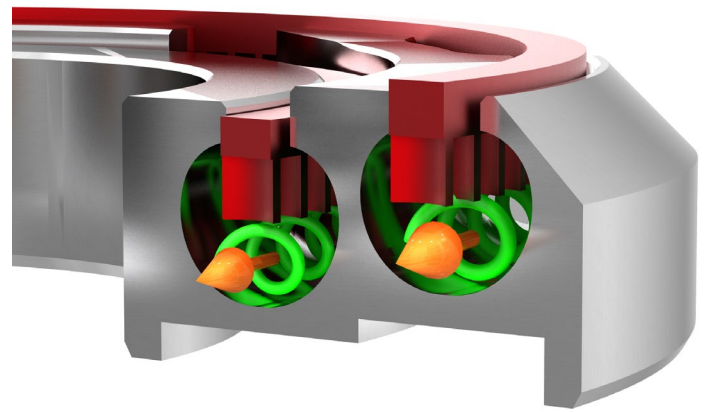

Regenerative stage

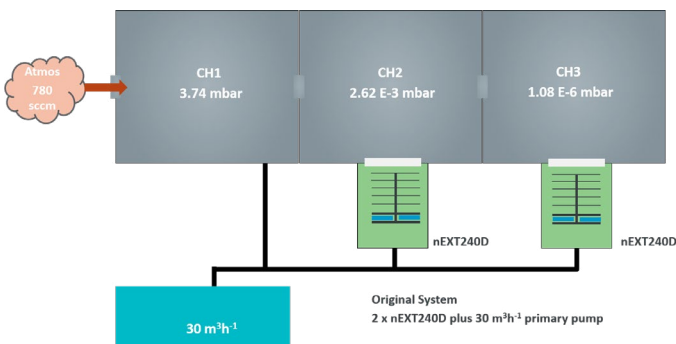

Original System

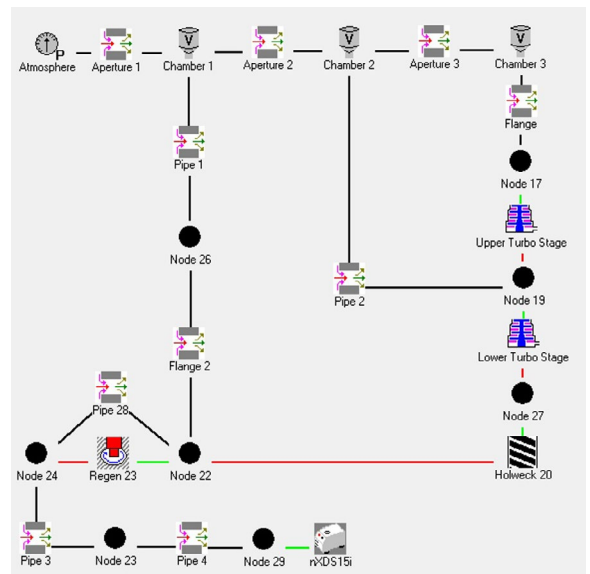

Screenshot taken from TransCalc HSM

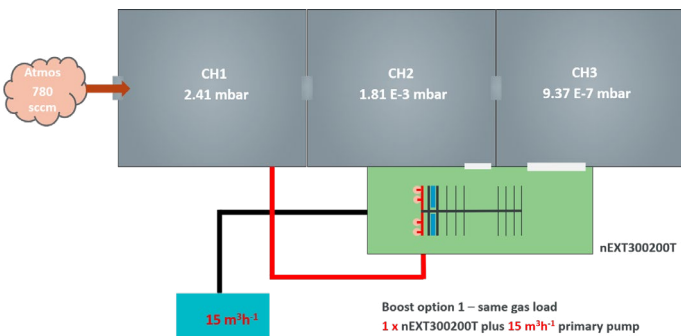

Boost Option 1

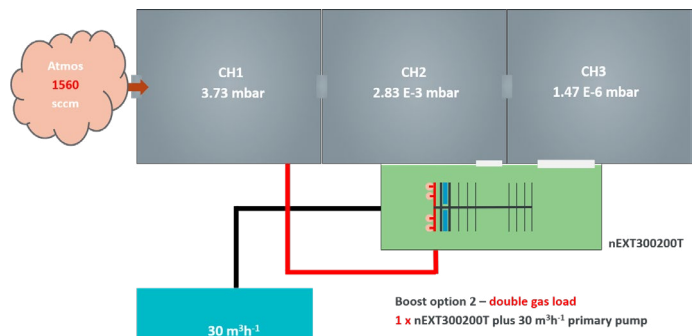

Boost Option 2



## TECHNICAL SPECIFICATIONS

		nEXT240	nEXT300	nEXT400
Inlet flange		DN100 ISO-K or DN100 CF	DN100 ISO-K or DN100 CF	DN160 ISO-K or DN160 CF
Inlet pumping speed $l s^{-1}$	N <sub>2</sub>	240	300	400
	Ar	230	280	380
	He	230	340	390
	H <sub>2</sub>	165	280	325
Compression ratio (D)	N <sub>2</sub> /Ar	$>1 \times 10^{11}$	$>1 \times 10^{11}$	$>1 \times 10^{11}$
	He	$3 \times 10^5$	$1 \times 10^6$	$1 \times 10^8$
	H <sub>2</sub>	$1 \times 10^4$	$5 \times 10^4$	$5 \times 10^5$
Compression ratio (T/H)	N <sub>2</sub> /Ar	$>1 \times 10^{11}$	$>1 \times 10^{11}$	$>1 \times 10^{11}$
	He	$1 \times 10^6$	$3 \times 10^6$	$>1 \times 10^8$
	H <sub>2</sub>	$1.5 \times 10^4$	$1 \times 10^5$	$1 \times 10^6$
Backing/interstage/boost ports		NW25	NW25	NW25
Vent/purge port		1/8" BSPP	1/8" BSPP	1/8" BSPP
Critical backing pressure (D/H)	mbar	9.5	9.5	10
Critical backing pressure (T)	mbar	20	20	20
Bake out water cooled/forced air cooled max.	°C	120/115°	120/115°	120/115°
Recommended backing pump*		RV12/nXDS10i	RV12/nXDS10i	RV12/nXDS10i
Normal rotational speed (rpm)		60,000	60,000	60,000
Start time to 90% speed (sec) D/H (T)		115 (150)	145 (190)	180 (210)
Mass (kg) D/H (T)	ISO	5.7 (6)	5.7 (6)	6.5 (6.8)
	CF	8.8 (9.1)	8.5 (8.8)	9.5 (9.8)

\* A smaller backing pump may be used depending on application.

## DIMENSIONS

### nEXT240D

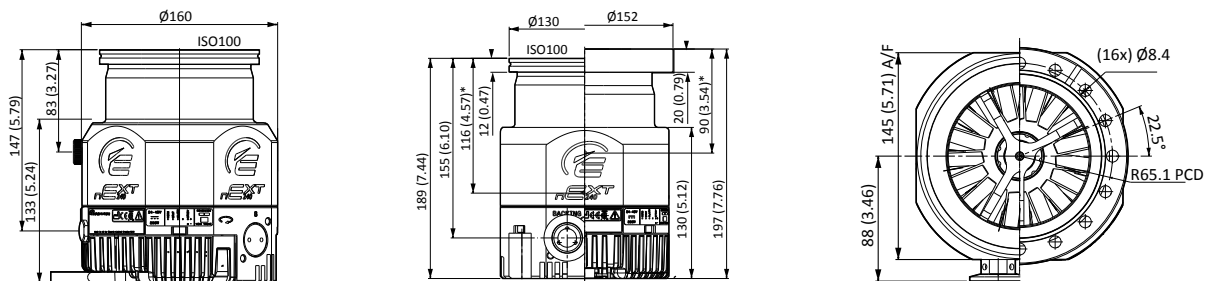

## nEXT300D

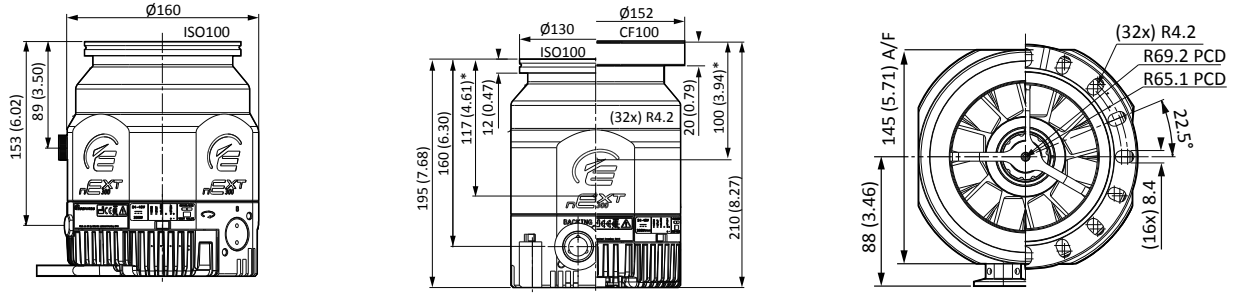

## nEXT400D

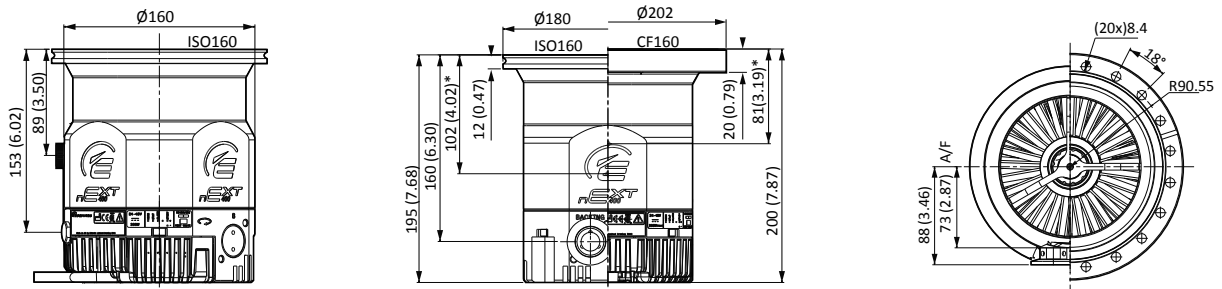

## PERFORMANCE

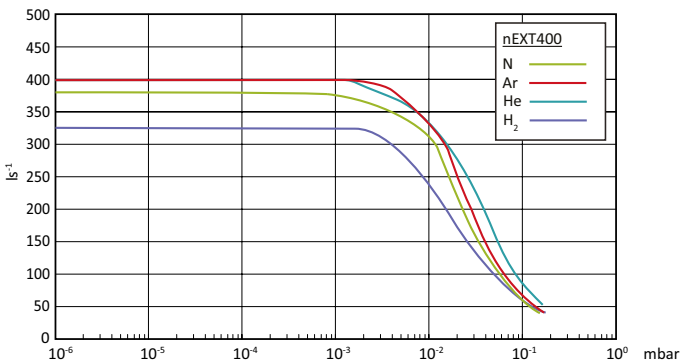
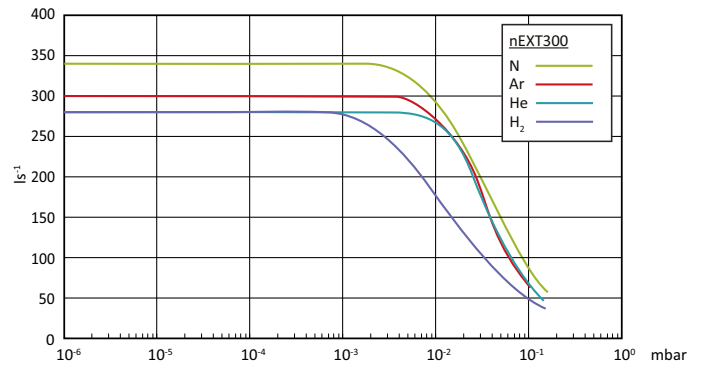
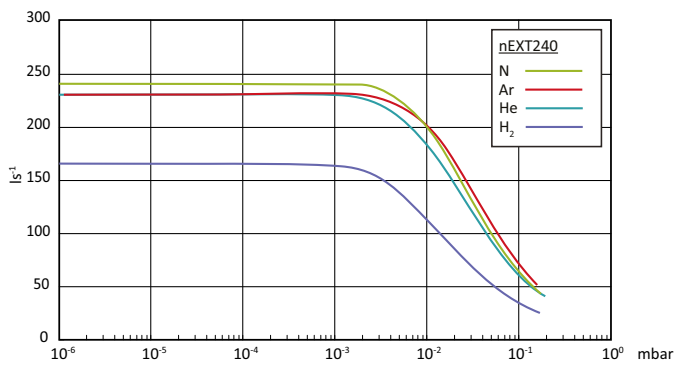

# nEXT730, nEXT930, nEXT1230 TURBOMOLECULAR PUMP

---

With the nEXT730, nEXT930 and nEXT1230 turbomolecular pumps Edwards provides larger pumps offering nitrogen pumping speeds of 730, 925 and 1250 l/s respectively.

As well as addressing the general R&D market, where high pumping speeds are often required, these pumps are also designed to meet the requirements of the coating market and other diffuse market sectors such as Heat treatment, furnace applications, E-beam welding, Etch, Ion implant, Degassing and Cylinder evacuation.

For our OEM customers, derivative versions of these products including split flow variants can be developed to match specific applications.

These compact pumps are able to operate in any orientation, and are supported by a full range of accessories for cooling, venting, powering and control.

The pumps feature bearings with a typical life time of at least 4 years with no maintenance. When required, a bearing replacement can be undertaken by the customer themselves or they can take advantage of our other service support options.



## TECHNICAL SPECIFICATIONS

		nEXT730D		nEXT930D		nEXT1230H			
Inlet flange		DN 160 ISO-K	DN 160 CF	DN 200 ISO-K	DN 200 CF	DN 200 CF	DN 200 ISO-F	DN 200 ISO-K	
<b>Main inlet pumping speed</b>									
Inlet pumping speed ls <sup>-1</sup>	N <sub>2</sub>	730		925		1250			
	Ar	665		865		1150			
	He	820		905		1350			
	H <sub>2</sub>	715		735		1150			
<b>Gas throughput</b>									
Gas throughput mbar ls <sup>-1</sup>	N <sub>2</sub>	14				12			
	Ar	3.5				4			
	He	21				>20			
	H <sub>2</sub>	>> 14				>20			
<b>Peak compression ratio backing port to main inlet port</b>									
Compression ratio	N <sub>2</sub>	> 1x10 <sup>11</sup>							
	Ar	> 1x10 <sup>11</sup>							
	He	1,2x10 <sup>8</sup>				4 x 10 <sup>-8</sup>			
	H <sub>2</sub>	4,0x10 <sup>6</sup>				1 x 10 <sup>-7</sup>			
Ultimate pressure with 2-stage oil sealed rotary vane pump ISO-K/CF	mbar	< 3,5x10 <sup>-9</sup>	< 6x10 <sup>-10</sup>	< 3,5x10 <sup>-9</sup>	< 6x10 <sup>-10</sup>	< 5 x 10 <sup>-10</sup>	< 5 x 10 <sup>-9</sup>		
Backing/interstage/boost ports		NW40							
Normal rotational speed	rpm	49 200				42 000			
Start time to 90% speed (sec) D/H (T)	min	2.5				3			
Cooling water consumption	l/h	60							
Critical backing pressure	mbar	6							
Mass (kg) D/H (T)	kg	14.6	19.6	15.4	21.7	32.6	24.9	23.7	
Recommended backing pump*		nXRi, XDS35i, E2M28*							
Bake out water cooled/forced air cooled max.	°C	n/a	100	n/a	100		n/a		
Vent/purge port		G 1/8"							

\*Please contact your local representative to discuss the correct option for your application.



# DIMENSIONS

## nEXT730D

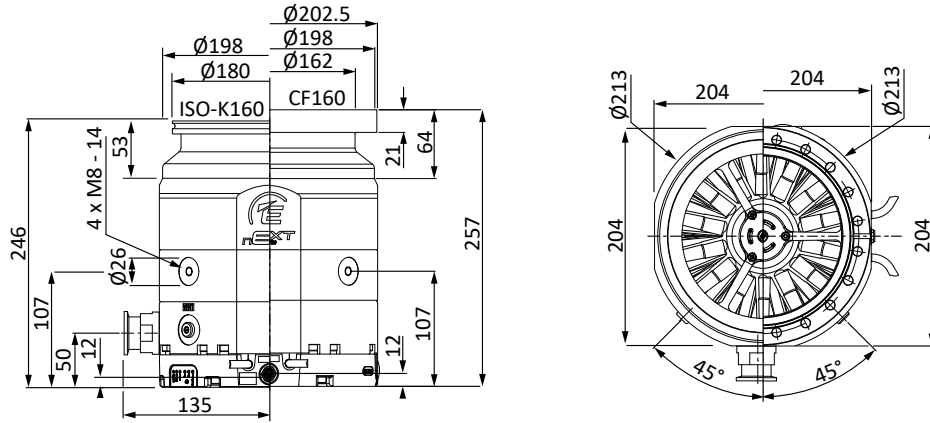

## nEXT930D

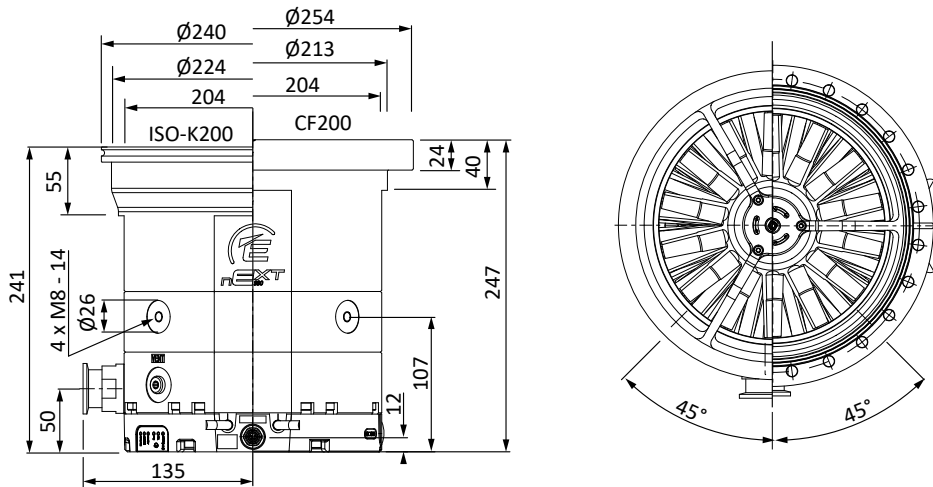

## nEXT1230H

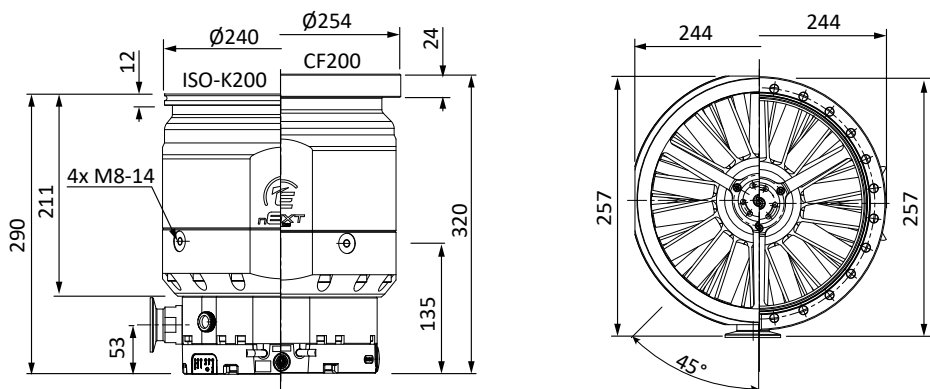

## PERFORMANCE

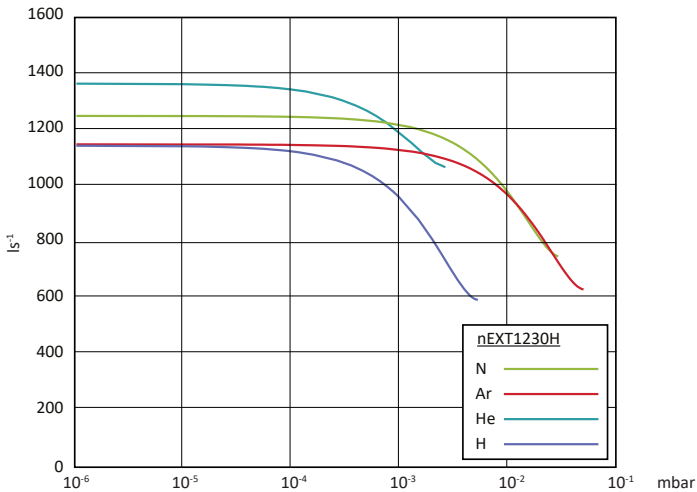
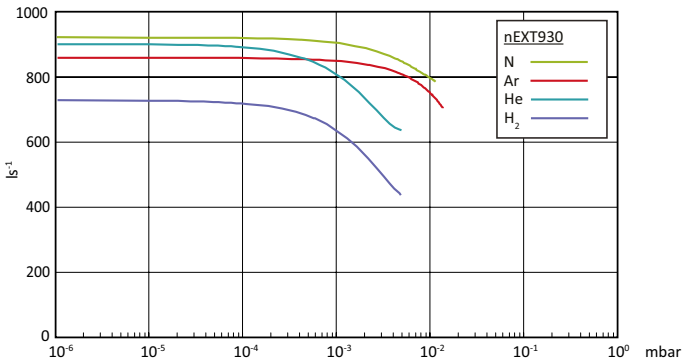
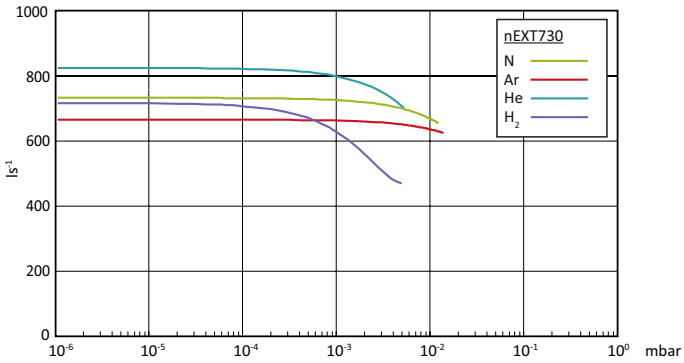

## BESPOKE PRODUCT DEVELOPMENT

With Edwards, you can quickly and accurately create the perfect vacuum solution for your needs. When an off the shelf pump will not meet your requirements for space or performance, our Bespoke Product Development (BPD) team will develop a customised vacuum solution to turn your requirement into reality.

At Edwards, a partnership approach is taken to system design, and it all starts with a vacuum expert gathering your application details: what pressures you wish to achieve, what gas flows you have, how much space is available etc. Our expert then uses a number of in-house and publicly available modelling tools at his disposal to optimise your vacuum system. Developed by our Analytical Services group, these tools are used to model complete vacuum systems from atmosphere down to ultra-high vacuum (UHV). This software has been developed to give rapid simulation of the behaviour of the proposed vacuum solution to ensure that it perfectly meets your requirements.

Accurate computer modelling offers you the chance to streamline your development cycle, avoiding a costly iterative approach and delivering a quicker time to market. Please contact Edwards to take advantage of this service.



## CONTROLLERS AND ACCESSORIES

The TIC (Turbo and Instrument Controller) automatically recognises and supports one turbomolecular pump from the nEXT range, One backing pump (nxds, or diaphragm) plus three Edwards active gauges on top of that Cooling and vent valve support is provided directly from the controller. Backing pump power is provided for a compact 24V diaphragm pump (on 200W versions only), or where greater pumping speeds are required, nXDS and large XDS pumps can be controlled directly via the backing pump connector on a TIC 200 mains backing pumps (up to RV12) may be controlled via an optional relay box.

The relay box can also be used to control a mains heater band and backing line isolation valve. Time delays and normal speed signals may be used to control events such as turbo start and there is a comprehensive selection of protection and safety interlock features. The TIC turbo controller may be either rack or bench mounted and provides a useful hub for the flexible operation of a wide range of vacuum system configurations.



The **TAG (Turbo and Active Gauge)** controller is a small, compact, low cost pumping system controller, which is suitable for a wide range of vacuum applications. It is a 24V controller that is compatible with all Edwards nEXT turbomolecular pumps. In addition to a turbomolecular pump it can control a backing pump, a vent valve, an air cooler and an Edwards active gauge. The TAG is controlled by an easy to use interface. A large clear LED display shows the pump speed or vacuum pressure. The compact size of the controller is ideal for use on bench-tops or suitable mobile platforms.

## END USER SERVICEABILITY

New technologies employed in nEXT have enabled the pumps to be serviced by the end user in the field. An oil lubrication cartridge change can be performed where fitted, typically in less than 5 minutes. A full bearing change can also be performed by the end user in around 10 minutes on all nEXT pumps. Both with the minimum of specialist tooling. These simple interventions will, in many cases, mean that the pump never requires a full return to base service during its lifetime.

nEXT turbomolecular pumps will advise the user when a service is due and what level of intervention is required. The user is alerted to a service request by a simple flashing LED sequence on the pumps and by serial comms notification.

Flexibility is again key as these simple services can be performed either by the end user, on site by an Edwards field service technician, or the pump can be returned to an Edwards service hub.

Using remote diagnostics, a user can interrogate the pump to determine how long it is to the next service so that a proactive approach to preventative maintenance can be planned.

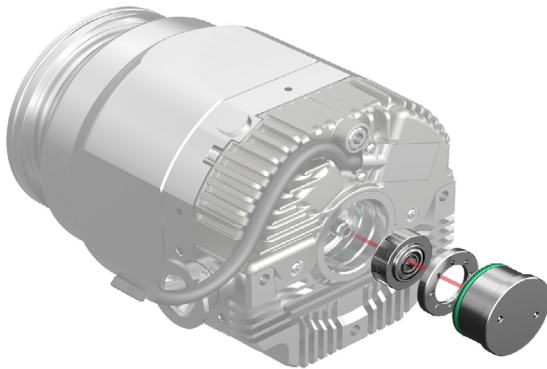

**nEXT55, 85, 240, 300, 400**

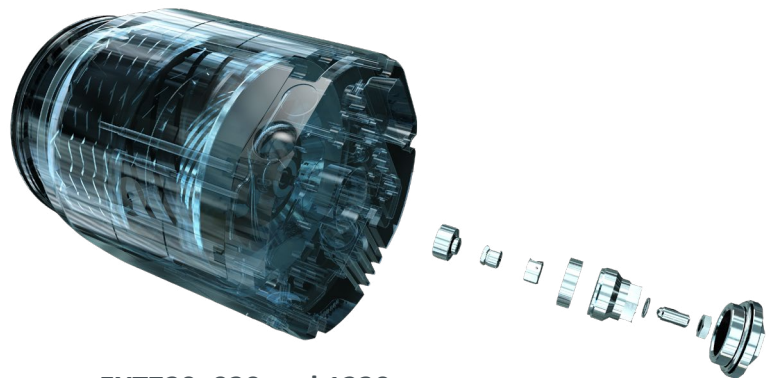

**nEXT730, 930 and 1230**

## PROLONGED PEACE OF MIND

Extending the new equipment warranty gives you a simple opportunity to add peace of mind to your purchase of new equipment, should a fault occur as a result of a manufacturing defect, equipment is expressly repaired or replaced.

Cover is available on many of our products allowing the original factory warranty to be extended from 12 months to 2 years and beyond.

## YOUR GLOBAL PARTNER

We understand the importance of local support. Edwards has a number of major service facilities located throughout the world, each location is supported by an extensive team of engineers and technicians to provide local, rapid response and great value service. All our service operations are conducted at the highest international standards in accordance with ISO9001 (Quality), ISO14001 (Environmental), and OHSAS18001 (Workplace safety).





## ORDERING INFORMATION

Pumps:

Product description	Order number
nEXT55D NW40 NW16 80W	B8E210A01
nEXT55D CF63 NW16 80W	B8E210C01
nEXT55D ISO63 NW16 80W	B8E210B01
nEXT55D ISO100 NW16 80W	B8E210101
nEXT85D ISO63 NW16 80W	B8G210B01
nEXT85D CF63 NW16 80W	B8G210C01
nEXT85D ISO100 NW16 80W	B8G210101
nEXT85D NW40 NW16 80W	B8G210A01
nEXT85D ISO100 NW25 80W	B8G240101
nEXT85iD ISO63 NW16/16 80W	B8G211B01
nEXT85iD ISO63 NW16/25 80W	B8G214B01
nEXT85H ISO63 NW16 80W	B8G410B01
nEXT85H CF63 NW16 80W	B8G410C01
nEXT85H NW40 NW16 80W	B8G410A01
nEXT85iH CF63 NW16/16 80W	B8G411C01
nEXT85H ISO100 NW16 80W	B8G410101
nEXT240D ISO-K100 160W	B81200100
nEXT240D CF100 160W	B81200200
nEXT240T ISO-K100 160W	B81300100
nEXT240T CF100 160W	B81300200
nEXT300D ISO-K100 160W	B82200100
nEXT300D CF100 160W	B82200200
nEXT300T ISO-K100 160W	B82300100
nEXT300T CF100 160W	B82300200
nEXT400D ISO-K160 160W	B83200300
nEXT400D CF160 160W	B83200400
nEXT400T ISO-K160 160W	B83300300
nEXT400T CF160 160W	B83300400
nEXT730D ISO-K160 NW25	B8J200300
nEXT730D CF160 NW25	B8J200400
nEXT930D ISO-K200 NW25	B8K200D00
nEXT930D CF200 NW25	B8K200F00
nEXT1230H CF200 NW40	B8N4A0F00
nEXT1230H ISO-F200 NW40	B8N4A0E00
nEXT1230H ISO-K200 NW40	B8N4A0D00
nEXT1230H CF200 NW40 INV	B8N4A0FU0
nEXT1230H ISO-F200 NW40 INV	B8N4A0EU0
nEXT1230H ISO-K200 NW40 INV	B8N4A0DU0

*Other insterstage port positions available upon request*

## ORDERING INFORMATION

Accessories and spares:

Pump		Product description	Order number
nEXT55/85	Controller <sup>(1)</sup>	TAG controller	D39592000
		TAG power supply	D39592800
		TIC 200 turbo and instrument controller	D39721000
	Cooling	WCX85 water cooling kit (4 position)	B8G200833
		ACX85 air cooler connector fitted	B8G200820
	Venting	N/O TAV5 vent valve connector fitted	B8G200834
		N/C TAV5 vent valve connector fitted	B8G200835
	Bakeout	CF63 flange heater 110 V	B8G200823
		CF63 flange heater 240 V	B8G200824
	Service	Oil cartridge kit	B8G200828
		Bearing and oil cartridge kit	B8G200811
		Bearing replacement tool kit	B8G200845
	Miscellaneous	Accessory "Y" adaptor	B8G200837
		Accessory cable 90 degree/extension	B8G200836
		Accessory connector bare wired	B8G200839
nEXT85/EXT75DX base mounting adaptor		B8G200838	
nEXT240/ 300/400	Controller <sup>(1)</sup>	TAG controller	D39592000
		TAG power supply	D39592800
		TIC100 turbo and instrument controller	D39722000
	Cooling	nEXT radial air cooler	B58053175
		nEXT axial air cooler	B58053185
		nEXT water cooler	B80000815
	Bakeout	CF100 flange heater 100-120 V	B58052773
		CF100 flange heater 200-240 V	B58052774
		CF160 flange heater 100-120 V	B58052775
		CF160 flange heater 200-240 V	B58052776
	Venting	TAV5 solenoid operated vent valve	B58066010
	Service	Oil cartridge tool kit	B80000812
		Bearing tool kit	B80000805
		Oil cartridge	B80000811
		Bearing and oil cartridge	B80000810

## ORDERING INFORMATION

Accessories and spares:

Pump	Product description	Order number		
nEXT730/ 930/1230	Controllers	TAG controller	D39592000	
		TAG power supply	D39592800	
		TIC100 turbo and instrument controller	D39721000	
	Cooling	Air cooling nEXT730/930 /1230 radial	B8J200800	
		Water cooling nEXT730/930, 1/4"	B8J200820	
	Venting	N/O TAV5 vent valve connector fitted	B8G200834	
		N/C TAV5 vent valve connector fitted	B8G200835	
		Vent port adaptor	B58066011	
	Inlet screens	Center ring w. prot. screen DN200 ISO-K coarse	B8J200807	
		Center ring w. prot. screen DN200 ISO-K fine	B8J200808	
		Coarse inlet screen DN 200 CF	B8J200809	
		Fine inlet screen DN 200 CF	B8J200810	
		CF160 coarse inlet screen	B80000823	
		CF160 fine inlet screen	B80000824	
		ISO160 coarse inlet screen	B80000825	
	Service	Bearing replacement kit	B8J200827	
		Bearing replacement tooling	B8J200845	
	Mains input cable	Mains input cable 3m UK	B8J200814	
		Mains input cable 3m EU	B8J200812	
		Mains input cable 3m US	B8J200813	
	Power supply to pump	EPS 800	B8J200819	
		3m EU (mains cable) EPS 800, IP54 protected	B8J200829	
		3m EU (mains cable) EPS 800, IP54 protected	B8J200830	
		3m EU (mains cable) EPS 800, IP54 protected	B8J200831	
		nEXT 3m extension cable for EPS 800	B8J200824	
		nEXT 5m extension cable for the EPS 800	B8J200825	
		Cable nEXT supply 48VDC 1m	B8J200821	To connect the EPS 800 power supply to the pump
		Cable nEXT supply 48VDC 3m	B8J200822	To connect the power supply to the pump
		Cable nEXT supply 48VDC 5m	B8J200823	To connect the power supply to the pump
		nEXT 1m open end cable	B8J200815	To connect a 3rd party power supply to the pump
		nEXT 3m open end cable	B8J200816	
		nEXT 5m open end cable	B8J200817	
		EPS 800 mount kit to place the power supply directly on the pump	B8J200832	
	Miscellaneous	Accessory "Y" adaptor	B8G200837	
		Accessory cable 90 degree/extension	B8G200836	
		Accessory connector bare wired	B8G200839	
	Extension cables	1 m pump to controller cable	D39700835	
		3 m pump to controller cable	D39700836	
		5 m pump to controller cable	D39700837	
	Power cables <sup>(1)</sup>	2 m electrical supply cable UK plug	D40013025	
		2 m electrical supply cable EU plug	D40013030	
		2 m electrical supply cable US plug	D40013120	
	Miscellaneous	Vent port adaptor	B58066011	
PRX10 purge restrictor		B58065001		
TIC relay		D39711805		

(1) Denotes need second annotation 730 and bigger pumps need their own power supply required accessory. Others optional depending on application.



## Global contacts

Publication Number: 3601 0091 01  
 © Edwards Limited 2021. All rights reserved  
 Edwards and the Edwards logo are trademarks of  
 Edwards Limited.

Whilst we make every effort to ensure that we  
 accurately describe our products and services,  
 we give no guarantee as to the accuracy or  
 completeness of any information provided in  
 this brochure.

Edwards Ltd, registered in England and Wales  
 No. 6124750, registered office: Innovation Drive,  
 Burgess Hill, West Sussex, RH15 9TW, UK.

### EMEA

<b>UK</b>	+44 1444 253 000 (local rate) 08459 212223
<b>Belgium</b>	+44 1293 60 3350
<b>France</b>	+33 1 4121 1256
<b>Germany</b>	0800 000 1456
<b>Italy</b>	+ 39 02 48 4471
<b>Israel</b>	+ 972 8 681 0633
<b>Russia</b>	+7 495 933 55 50 Ext. 1800/1803 +8 800 775 80 99

### ASIA PACIFIC

<b>China</b>	+86 400 111 9618
<b>India</b>	+91 20 4075 2222
<b>Japan</b>	+81 47 458 8836
<b>Korea</b>	+82 31 716 7070
<b>Singapore</b>	+65 6546 8408
<b>Taiwan</b>	+886 3758 1000

### AMERICAS

<b>USA</b>	+1 800 848 9800
<b>Brazil</b>	+55 11 3952 5000