

NAF Duball DL Ball Valves

FCD NFENTB4167-01-A4 12/14

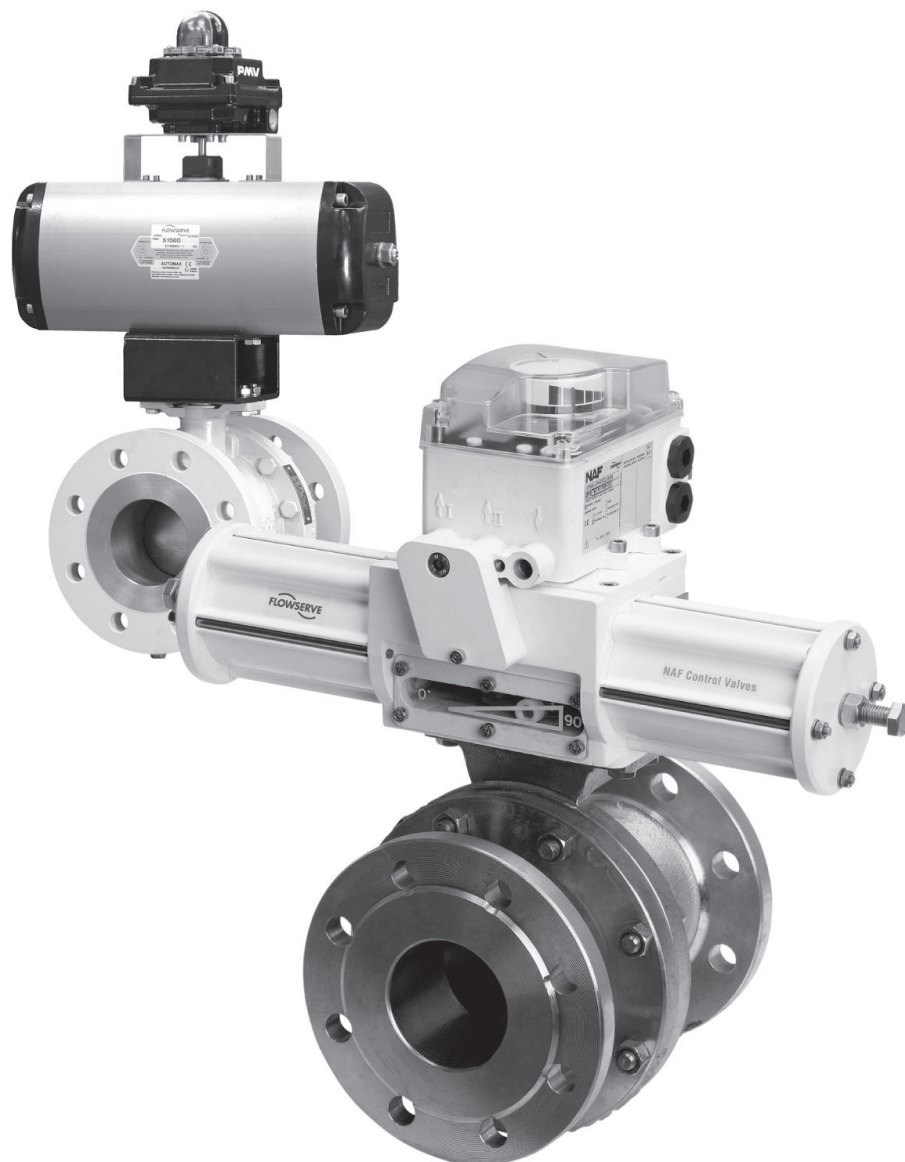

Primary Characteristics

NAF Duball DL is a full-bore ball valve which is equally suitable for isolation, on/off and modulating control applications. The NAF Duball DL is supplied as standard in stainless steel or carbon steel, but is also available in other materials, such as Duplex, titanium, etc.

The NAF Duball DL is the fourth generation of the Duball portfolio, one of the most proven ball valve portfolios in the industry.

The valve has:

- A **spring loaded stem seal packing** that provides a long, maintenance free and safe operation in automated on/off and control service
- **Direct actuator mounting** capabilities of the NAF Turnex actuator which provides a high performance, vibration resistant, compact valve package
- A sturdy, **blowout-proof stem** with a long foot providing a high torque transmission with a **minimum mechanical backlash**
- A floating ball that provides **bidirectional tightness**
- The **unique Z-trim** option that **minimizes cavitation and noise** and has **excellent control characteristics**
- An **extensive size range**, DN 25–400, size 1” to 16”
- An **easy-to-service arrangement**, due to the off-center joint face of the valve body, which allows for easy replacement of the ball and seals, without the need for removing the stem and actuator
- **Metal seats** with a rigid welded overlay of Alloy 6 or alternatively, **metal encapsulated, reinforced PTFE seats**
- A wide range of **optional versions**, including **fire safe** tested versions acc. to API 607/ISO 10497

CE-marked according to Pressure Equipment Directive (PED 97/23/EG) module H, category III. For module H1, category IV contact NAF

Technical specifications for standard design

Material	Stainless steel, carbon steel
Size range	DN 25-400, 1"-16"
Pressure ratings	PN 10-40, ANSI Class 150-300
Face to Face lengths	PN 10-16: EN558-1 series 12 (SSG 1042) PN 25-40: EN558-1 series 4 (SSG 1043) ANSI 150: ANSI B 16.10 Class 150 long ANSI 300: ANSI B 16.10 Class 300 short Size 1"-12" Class 300 long Size 14"-16"
Valve Design	ANSI B16.34 or EN 12 516
Installation method	Flanges to EN or ANSI B 16.5
Temperature Range	-30 - 250C, see graph on page 6 and 7
Test procedure	Body: 1.5 x maximum working pressure Seat: 1.1 x maximum allowed differential pressure Testing medium is water with inhibitor ¹
Tightness class	Soft seats EN 12266-1:2012, rate A (ISO 5208, rate A) Metal seats EN 60534-4 Class V ANSI FCI 70-2 Class V

¹Gas test upon request

Applications

The excellent characteristics of NAF Duball DL are particularly beneficial under the most challenging operating conditions in the process industry, where difficult media and demanding pressure conditions make severe demands on the design, materials and performance.

NAF Duball DL is recommended for applications in the following industries:

- **Chemical and Petrochemical**
- **Pulp and Paper**
- **Oil and Gas**
- **Power Stations**
- **Metals and Mining**
- **General Industries**

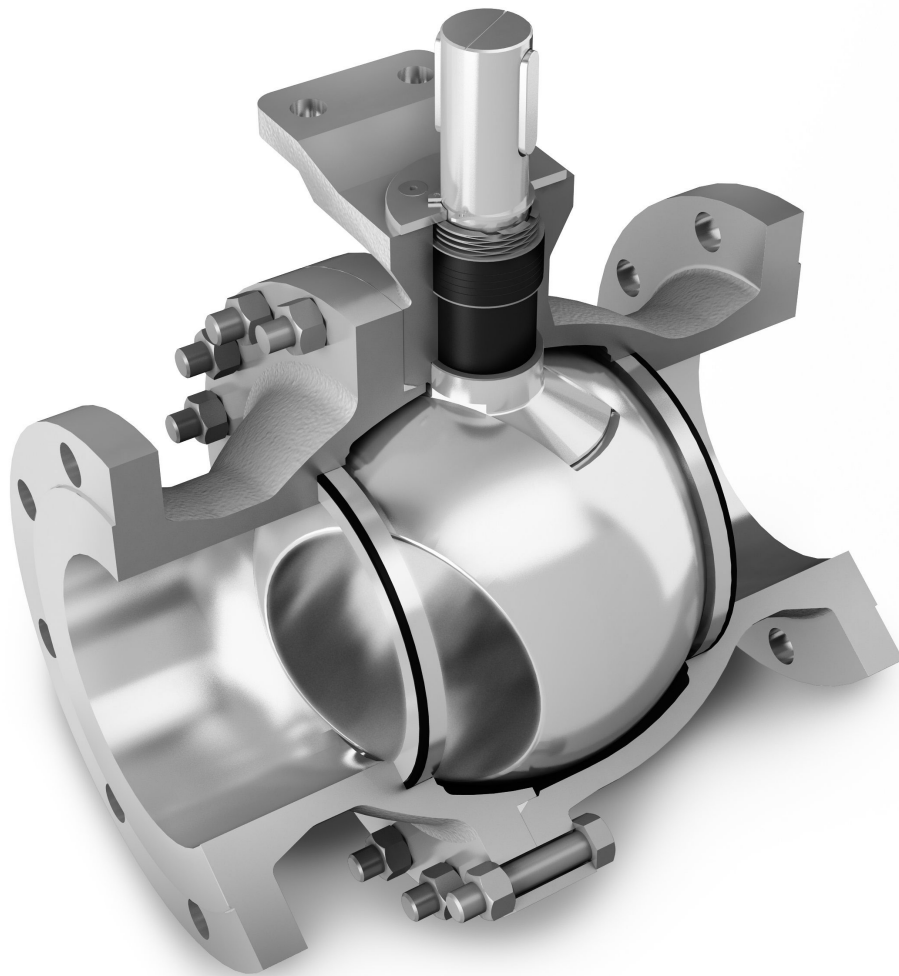

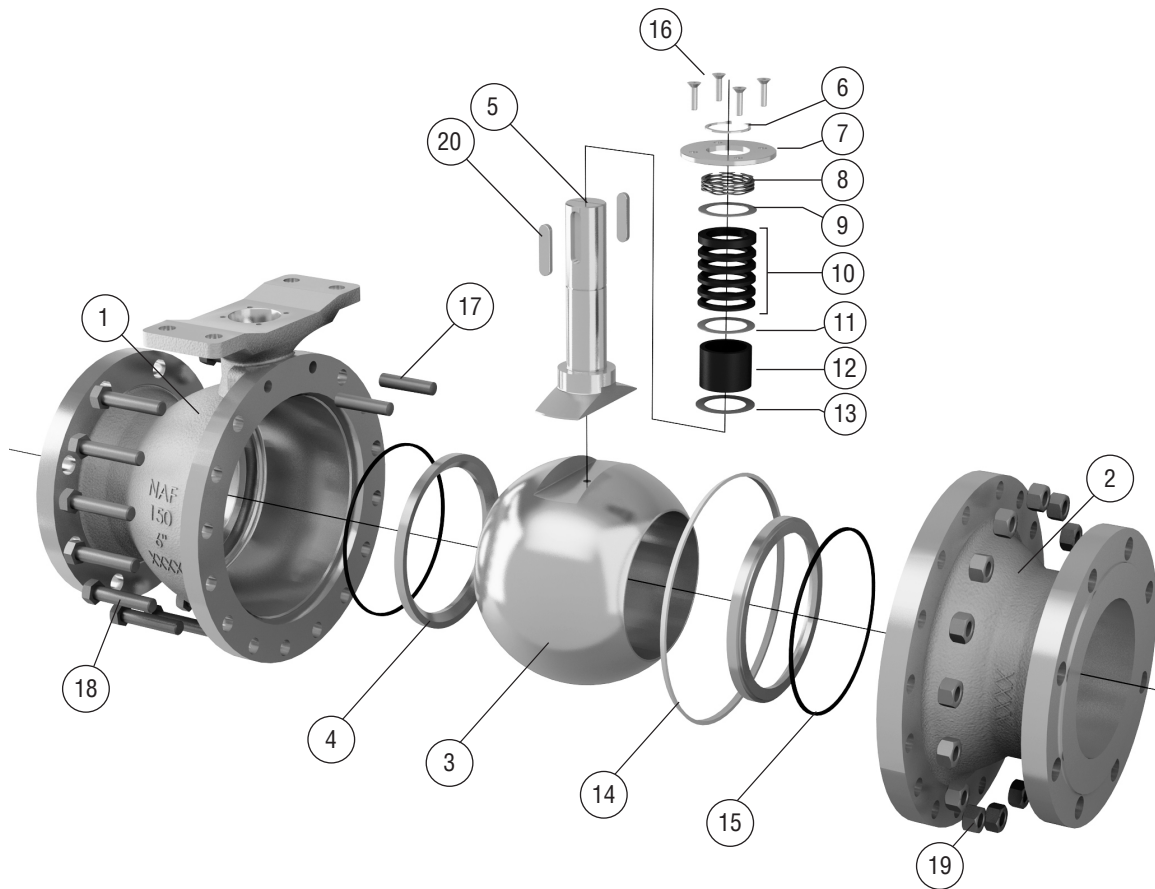
Table 1: Materials (metal seated, standard version)

Item	Qty	Part	Stainless steel	Carbon steel
1	1	Body, main	CF8M / 1.4408	WCB
2	1	Body, cover	CF8M / 1.4 408	WCB
3	1	Ball	CF8M / 1.4408 + Hard Chrome Plated	
4 ¹	2	Seat ring	SS / Alloy 6	
5	1	Stem	EN 1.4460 (type AISI 329)	
6	1	Circlip	A2	
7	1	Cover	AISI 316L / EN 1.4404	
8	1	Spring	17-7PH	
9	1	Washer	AISI 316L / EN 1.4404	
10 ¹	1	Stem packing	R-PTFE carbon reinforced	
11 ¹	1	Washer	AISI 316L / EN 1.4404	
12 ¹	1	Bushing	R-PTFE carbon reinforced	
13 ¹	1	Anti-friction washer	PTFE + stainless steel	
14 ¹	1	Body seal	PTFE	
15 ¹	2	Seat seal	R-PTFE carbon reinforced	
16	2	Screw	A4	
17	2	Stud	A4/ASTM A193 gr. B8M	ASTM A193 gr. B7M
18	2	Bolt	A4/ASTM A193 gr. B8M	ASTM A193 gr. B7M
19	2	Nut	A4/ASTM A194 gr. 8M	ASTM A194 gr. 2HM
20	2	Key	A4	

¹ Recommended spare parts

² Qty depends on the size.

Material combinations others than those specified are available to order - consult your Flowserve NAF representative.

1.4408 = EN 10213-4 1.4408

CF8M = ASTM A351 gr. CF8M

WCB = ASTM A216 gr. WCB

Seat Rings

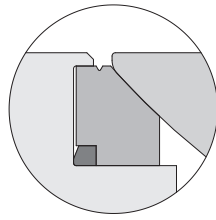

Metal seat standard

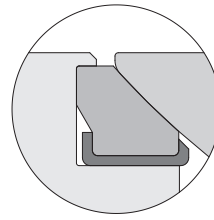

Soft seat standard

Other versions

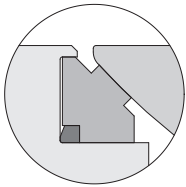

Scraper seat

Seat ring with scraper edge.

Option: S

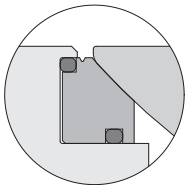

Sealed seat

Seat rings with two O-rings to prevent media penetrating behind seat ring. Used with media that crystallize.

For temperature limitations, please see code 8 in the product code.

Option: T

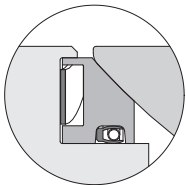

Spring loaded seat

If the differential pressure is low (below 0,5 bar) and a specified tightness must be maintained, O-rings or springs must be fitted behind the seat rings.

Option: E For temperature limitations, please see code 8 in the product code.
W (Wave spring) max 250 °C

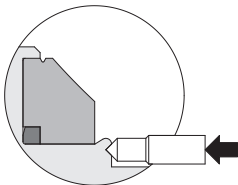

Locked seat rings

All valves are prepared for locking of the seat rings in the form of peening-over.

Option: L

- **Degreased for oxygen service.** NAF Duball DL has an option D which needs to be specified for oxygen service. In this version all components are de-greased before assembly and a special grease, which is approved for oxygen service, is used in assembly.

Option: D

- **Explosive atmosphere** when intended for use in an explosive atmosphere, please specify option XA. With this option, the valve is certified according to ATEX 94/9/EC .

Option: XA

- **Fire safe version**

NAF Duball DL is available in fire safe versions tested according to API 607, 6th edition (soft seated versions) and ISO 10497:2010 (soft and metal seated versions). For a list of approved versions, please contact your Flowserve NAF representative.

Option: Z (only together with stem seal F in code 9)

- **Straight cylindrical flow path for sizes DN300–400 / 12”–16”**

For sizes DN300–400 / 12”–16” the balls are delivered as hollow balls in the standard version. Option -C specifies a solid ball with a straight cylindrical flow path, normally used for applications such as blow-down and discharge valves.

Option: C

Working pressure and temperature

Max. working pressure PN rated valves

Stainless steel body (CF8M)

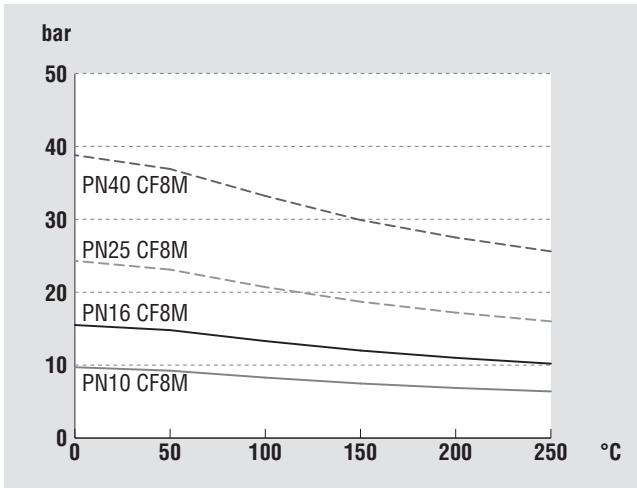

Carbon steel body (WCB)

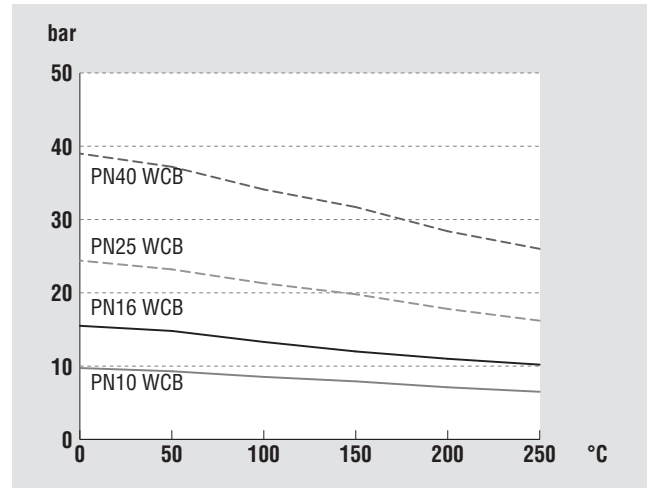

Max. working pressure ANSI rated valves

Stainless steel body (CF8M)

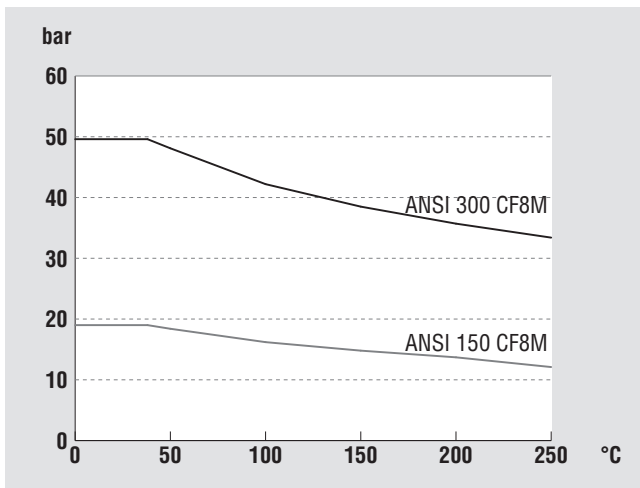

Carbon steel body (WCB)

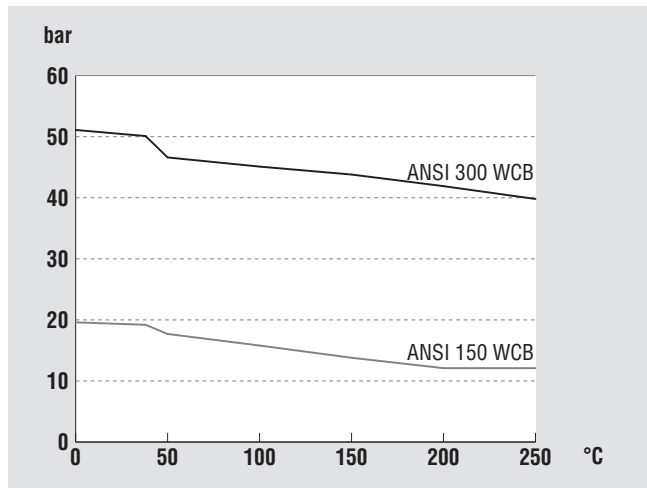

Differential pressure and temperature

Max. dp Alloy 6 seat

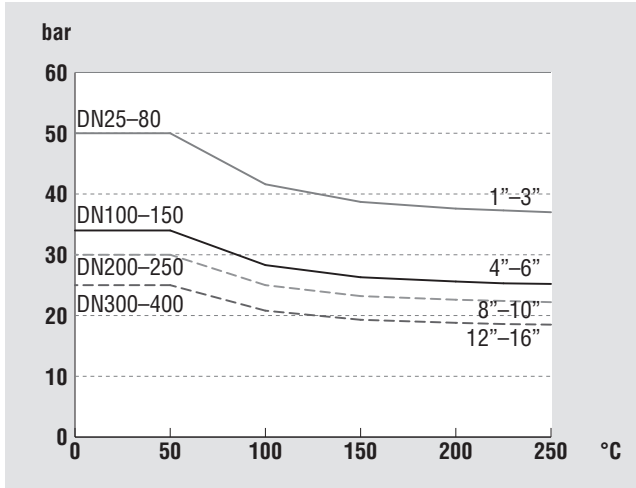

Please note that the maximum allowed differential pressure can be further reduced if the maximum allowed working pressure, based on body material and pressure class of the valve, is lower than the maximum allowed differential pressure.

Max. dp R-PTFE seat

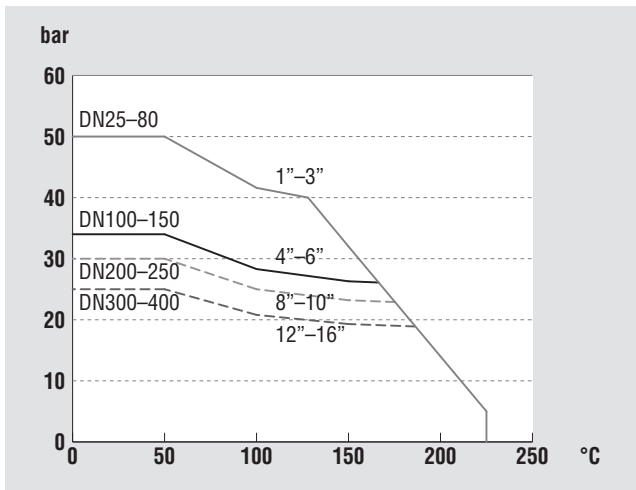

Soft R-PTFE seat ratings are based on differential pressure with the ball in the fully closed position and refer only to the seats. The maximum allowed differential pressure can be further reduced if the maximum allowed working pressure, based on body material and pressure class of the valve, is lower than the maximum allowed differential pressure.

Operating torque and flow capacities

Table 2: Operating torque, Nm

DN	Size	Differential pressure in bar																	
		5		10		16		20		25		30		35		40		50	
		PTFE	Alloy 6	PTFE	Alloy 6	PTFE	Alloy 6	PTFE	Alloy 6	PTFE	Alloy 6	PTFE	Alloy 6	PTFE	Alloy 6	PTFE	Alloy 6	PTFE	Alloy 6
25	1"	12	15	15	20	19	26	22	30	25	35	28	40	32	45	35	50	41	60
40	1.5"	16	20	22	28	29	37	34	43	40	50	46	58	52	65	58	73	70	88
50	2"	20	25	30	36	42	50	50	59	60	70	70	81	80	93	90	104	110	126
80	3"	55	65	91	109	135	161	164	196	200	240	236	284	273	328	309	371	381	459
100	4"	95	115	159	199	235	299	286	366	350	450	414	534	465 ¹	601 ¹	-	-	-	-
150	6"	300	350	500	613	740	928	900	1138	1100	1400	1300	1663	1460 ¹	1873 ¹	-	-	-	-
200	8"	750	930	1288	1573	1933	2344	2363	2858	2900	3500	3438	4143	-	-	-	-	-	-
250	10"	1500	1750	2425	2938	3535	4363	4275	5313	5200	6500	6125	7688	-	-	-	-	-	-
300	12"	2400	3200	4050	5150	6030	7490	7350	9050	9000	11000	-	-	-	-	-	-	-	-
350	14"	3800	4500	6475	7875	9685	11925	11825	14625	14500	18000	-	-	-	-	-	-	-	-
400	16"	5500	7000	9625	11750	14575	17450	17875	21250	22000	26000	-	-	-	-	-	-	-	-

¹ Torques given at max allowed Dp of 34 bar

The minimum design differential pressure for selecting the actuator is 5 bar.

The specified torques in the table above are for clean media. For steam and with Alloy 6 seat rings increase the required torque with factor 1.5.

If the media is a slurry or contains solids, etc., consult NAF.

Table 3: Flow capacities and characteristics

DN	Size	C _v at an opening angle of															
		15°	20°	25°	30°	35°	40°	45°	50°	55°	60°	65°	70°	75°	80°	85°	90°
25	1	0	1	2	2	3	4	5	7	9	12	17	24	34	47	61	72
40	1.5	0	2	3	5	7	10	14	19	25	33	44	60	86	123	165	191
50	2	1	4	5	6	8	14	22	31	39	49	64	89	132	192	255	284
80	3	2	7	16	21	33	49	63	77	101	138	188	247	338	506	768	874
100	4	3	11	23	31	55	79	98	123	165	225	295	380	522	800	1234	1489
150	6	8	53	75	97	146	183	276	333	389	519	735	953	1201	1913	3276	4365
200	8	14	57	92	137	213	269	345	479	652	829	1053	1484	2283	3414	5203	8556
250	10	22	119	172	283	332	492	702	897	1119	1477	2007	2644	3492	5291	9236	14031
300	12	31	132	245	417	552	714	934	1196	1504	1909	2491	3343	4635	6700	9777	12439
350	14	43	220	367	544	737	950	1197	1505	1911	2455	3191	4195	5594	7606	10596	15157
400	16	56	333	572	728	1067	1287	1601	2048	2633	3359	4292	5616	7647	10739	15006	19770

Note: For sizes > DN400 / 16" see Technical Bulletin for NAF-Trunnball DL

$$K_v = C_v / 1.16$$

Dimensions and Weight

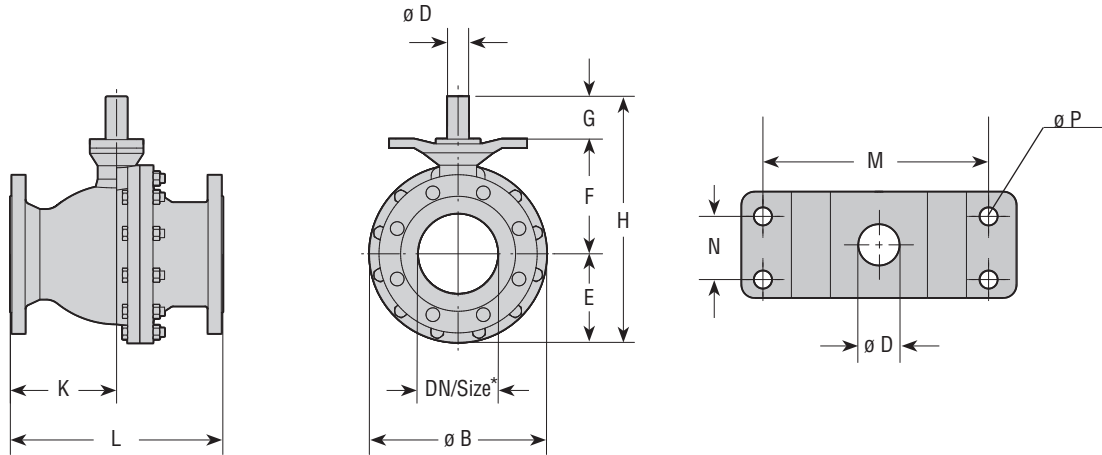

* Indicates nominal valve size

Table 4: Common dimensions - all pressure classes

DN	Size	Dimensions, mm								
		B	D	E	F	G	H	M	N	P
25	1"	124	16	62	83	38	183	115	30	11
40	1.5"	150	16	75	91	38	204	115	30	11
50	2"	165	20	83	106	43	232	115	30	11
80	3"	214	25	107	137	50	284	115	30	11
100	4"	244	25	122	152	50	324	115	30	11
150	6"	336	40	168	218	80	466	214	60	18
200	8"	452	50	226	268	93	587	214	60	18
250	10"	528	60	264	321	111	696	214	60	18
300	12"	622	70	311	379	131	821	277	115	33
350	14"	688	90	344	467	172	983	277	115	33
400	16"	767	100	384	518	190	1092	277	115	33

Table 5: Pressure class related dimensions and weights

DN	Size	Dimensions, mm																	
		PN10			PN16			PN25			PN40			ANSI 150			ANSI 300		
		K	L	Weight kg	K	L	Weight kg	K	L	Weight kg	K	L	Weight kg	K	L	Weight kg	K	L	Weight kg
25	1"									66	165	8	52	127	6	66	165	8	
40	1.5"				Identical to PN40					95	190	12	60	165	10	95	190	13	
50	2"				Choose PN40					108	216	15	74	178	14	108	216	16	
80	3"				121	241	26			142	283	31	102	203	27	142	283	33	
100	4"	Identical to PN16			153	305	38	Identical to PN40			153	305	43	107	229	39	153	305	50
150	6"	Choose PN16			197	394	91	Choose PN40			202	403	105	197	394	96	202	403	112
200	8"	229	457	172	229	457	172	251	502	199	251	502	210	229	457	175	210	419	204
250	10"	267	533	275	267	533	278	284	568	318	284	568	337	267	533	231	229	457	328
300	12"	305	610	341	305	610	349	324	648	358	324	648	454	305	610	359	251	502	430
350	14"	343	686	492	343	686	500	381	762	574	381	762	609	343	686	507	381	762	612
400	16"	381	762	647	381	762	657	419	838	753	419	838	813	381	762	668	419	838	801

Actuators

NAF Duball is available with hand levers or with pneumatic or electric actuators and accessories.

If other pneumatic or electric actuators are required, consult your Flowserve NAF representative.

The maximum differential pressure for selected actuator and valve is based on torque values in table 1 and is valid for clean media, e.g. water. For steam and other media, please see notes under table 2.

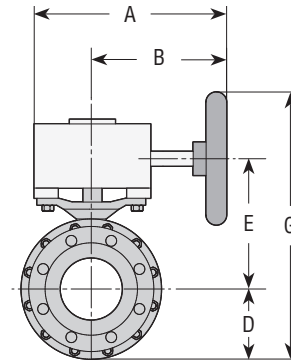
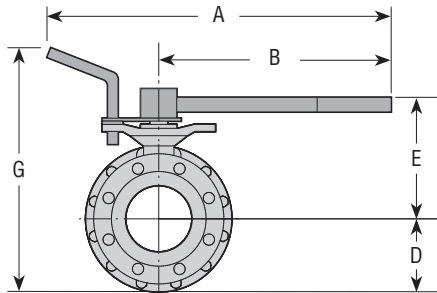

Table 6: NAF Duball valves with hand levers and worm gears

DN	Size	Max. dp bar Seat of		NAF No.	Dimensions, mm					Weight kg ¹
		R-PTFE	Alloy 6		A	B	D	E	G	
Hand lever as per Fk 70.51										
25	1"	25	25	791020-1	500	350	62	121	265	10
40	1.5"	25	25	-1	500	350	75	129	286	14
50	2"	25	25	-2	500	350	83	144	309	17
80	3"	15	13	-3	500	350	107	185	374	33
100	4"	10	8	-3	500	350	107	185	374	45

Worm gear actuator as per Fk 70.76 ²										
DN	Size	Max. dp bar Seat of R-PTFE	Max. dp bar Seat of Alloy 6	NAF No.	A	B	D	E	G	Weight kg ¹
25	1"	50	50	791051-11016	249	174	62	117	279	12
40	1.5"	50	50	791051-11016	249	174	75	125	300	16
50	2"	50	50	791051-11020	249	174	83	140	323	19
80	3"	50	50	791051-11025	249	174	107	171	378	35
100	4"	30	25	791051-11025	249	174	122	186	408	47
100	4"	50	50	791051-21025	328	243	122	195	467	51
150	6"	50	50	791051-33040	416	291	168	268	636	121
200	8"	16	12	791051-33050	416	291	226	333	759	226
200	8"	30	30	791051-43050	507	337	226	323	799	242
250	10"	18	14	791051-43060	507	337	264	376	890	369
250	10"	30	25	791051-53060	591	421	264	376	840	375
250	10"	30	30	791051-63060	697	487	264	410	974	404
300	12"	17	12	791051-55070	591	421	311	459	970	492
300	12"	25	25	791051-65070	697	487	311	468	1079	521
350	14"	20	16	791051-65090	697	487	344	591	1235	676
350	14"	25	23	791051-75090	747	537	344	591	1235	690
350	14"	25	25	791051-85090	848	593	344	552	1246	801
400	16"	13	10	791051-65100	697	487	384	657	1341	880
400	16"	17	14	791051-75100	747	537	384	657	1341	894
400	16"	25	25	791051-85100	848	593	384	628	1362	1005

¹ Applies to average weight of a PN40 valve + lever/gear

² Available with locking device - please contact NAF

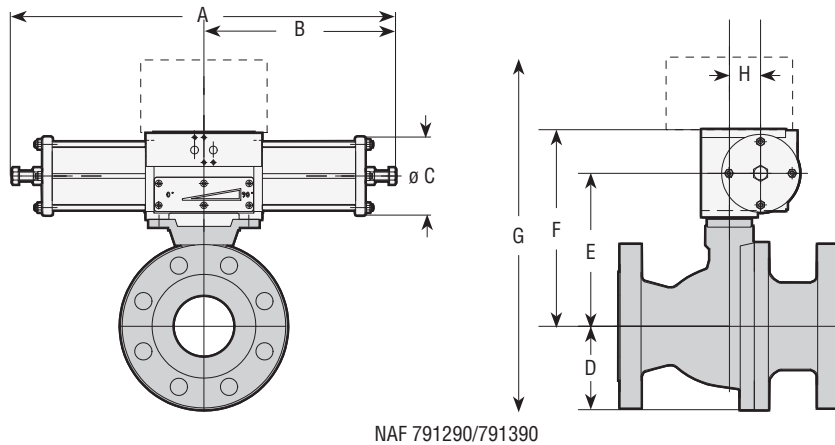

NAF 791290/791390

Table 7: NAF Duball valves with NAF Turnex pneumatic actuators (double acting)

The below stated dP apply for clean media type water 20 °C.
For other media contact NAF, see also page 8.

DN	Size	Max. dP bar at supply of						NAF No.	Dimensions, mm								Weight kg ¹
		4 bar		5 bar		6 bar			A	B	C	D	E	F	G ²	H	
		R-PTFE Alloy 6	R-PTFE Alloy 6	R-PTFE Alloy 6	R-PTFE Alloy 6	R-PTFE Alloy 6	R-PTFE Alloy 6										
Double-acting as per Fk74.59																	
25	1"	50	50	50	50	50	50	791390-0216	370	185	80	62	134	185	357	31	12
40	1.5"	50	45	50	50	50	50	791390-0216	370	185	80	75	142	193	378	31	16
50	2"	35	30	45	39	50	48	791390-0220	370	185	80	83	157	208	401	31	19
50	2"	50	50	50	50	50	50	791290-1220	490	245	100	83	162	218	411	40	21
80	3"	8	6	11	9	14	11	791390-0225	370	185	80	107	188	239	456	31	35
80	3"	19	15	24	20	30	24	791290-1225	490	245	100	107	193	249	466	40	37
80	3"	41	33	50	43	50	50	791290-2125	700	350	145	107	212	285	502	63	48
80	3"	50	50	50	50	50	50	791290-2225	700	350	145	107	212	285	502	63	48
100	4"	-	-	5	-	7	5	791390-0225	370	185	80	122	203	254	486	31	47
100	4"	10	7	13	9	16	12	791290-1225	490	245	100	122	208	264	496	40	49
100	4"	22	17	28	21	35	26	791290-2125	700	350	145	122	227	300	532	63	60
100	4"	34	34	34	34	34	34	791290-2225	700	350	145	122	227	300	532	63	60
150	6"	5	-	7	5	9	7	791290-2140	700	350	145	168	293	366	644	63	122
150	6"	13	10	17	13	21	16	791290-2240	700	350	145	168	293	366	644	63	122
150	6"	22	16	28	21	34	25	791290-3140	820	410	200	168	318	410	688	75	134
150	6"	34	34	34	34	34	34	791290-3240	820	410	200	168	318	410	688	75	134
200	8"	7	5	9	7	11	9	791290-3150	820	410	200	226	368	460	796	75	239
200	8"	16	13	20	16	25	20	791290-3250	820	410	200	226	368	460	796	75	239
200	8"	30	29	30	30	30	30	791390-4250	1110	555	260	226	396	499	835	100	255
250	10"	8	6	11	8	14	10	791390-4160	1110	555	260	264	449	552	926	100	382
250	10"	19	14	25	19	30	23	791390-4260	1110	555	260	264	449	552	926	100	382
250	10"	30	30	30	30	-	-	791390-4560	1250	695	395	264	449	552	926	100	447
250	10"	30	30	30	30	30	30	791390-5160	1600	800	395	264	503	651	1025	150	557
300	12"	-	-	5	-	7	-	791390-4170	1110	555	260	311	543	646	1067	100	499
300	12"	10	7	13	9	16	12	791390-4270	1110	555	260	311	543	646	1067	100	499
300	12"	20	16	25	21	-	-	791390-4570	1250	695	395	311	543	646	1067	100	564
300	12"	21	17	25	22	25	25	791390-5170	1600	800	395	311	561	709	1130	150	674
300	12"	25	25	25	25	25	25	791390-5270	1600	800	395	311	561	709	1130	150	674
350	14"	12	9	16	12	20	15	791390-5190	1600	800	395	344	649	797	1251	150	829
350	14"	25	21	25	25	25	25	791390-5290	1600	800	395	344	649	797	1251	150	829
400	16"	7	5	10	8	12	10	791390-5100	1600	800	395	384	700	848	1342	150	1033
400	16"	17	14	22	18	25	22	791390-5200	1600	800	395	384	700	848	1342	150	1033

¹ Applies to average weight of a PN40 valve + NAF Turnex actuator

² Including all direct mounted Flowserve positioners (NAF 37-series, NAF-LinkIT, PMV P5/EP5, PMV D3, PMV D20, Logix 520 MD Plus) that don't require mounting brackets

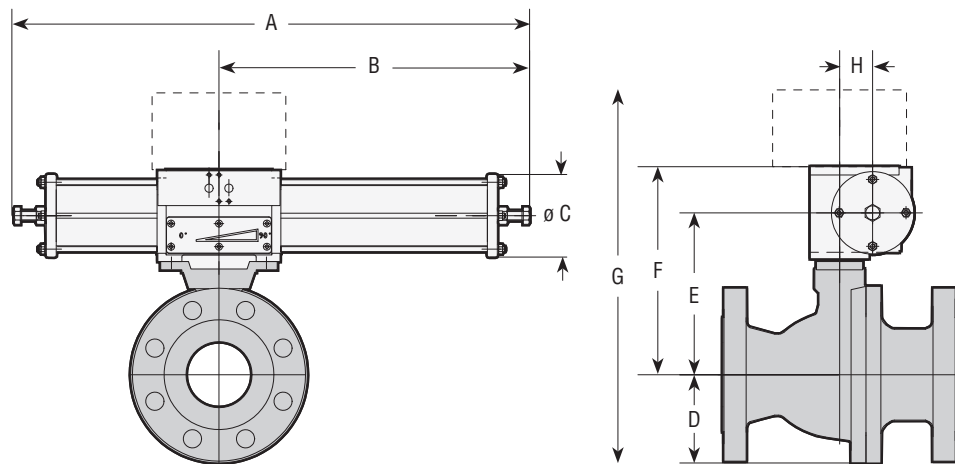

NAF791292/791392

Table 8a: NAF Duball valves with NAF Turnex pneumatic actuators (spring

The below stated dP apply for clean media type water 20 °C.
For other media contact NAF, see also page 8.

DN	Size	Max dP bar at supply of						NAF No.	Dimensions, mm								Weight kg ¹
		4 bar		5 bar		6 bar			A	B	C	D	E	F	G ²	H	
		R-PTFE Alloy 6	R-PTFE Alloy 6	R-PTFE Alloy 6	R-PTFE Alloy 6	R-PTFE Alloy 6	R-PTFE Alloy 6										
Single-acting, spring to close as per Fk 74.59																	
25	1"	50	35	50	41	50	41	791392-0216	455	270	80	62	134	185	357	31	13
25	1"	50	50	50	50	50	50	791292-1216	635	390	100	62	139	195	367	40	17
40	1.5"	29	21	41	26	41	26	791392-0216	455	270	80	75	142	193	378	31	17
40	1.5"	50	49	50	50	50	50	791292-1216	635	390	100	75	147	203	388	40	21
50	2"	17	13	24	16	24	16	791392-0220	455	270	80	83	157	208	401	31	20
50	2"	37	32	50	40	50	40	791292-1220	635	390	100	83	162	218	411	40	24
50	2"	50	50	50	50	50	50	791292-2220	890	540	145	83	180	253	446	63	38
80	3"	9	7	14	9	14	9	791292-1225	635	390	100	107	193	249	466	40	40
80	3"	44	36	50	45	50	45	791292-2225	890	540	145	107	212	285	502	63	54
80	3"	50	50	50	50	50	50	791292-3225	1050	640	200	107	237	329	546	75	74
100	4"	-	-	7	-	7	-	791292-1225	635	390	100	122	208	264	496	40	52
100	4"	24	18	34	23	34	23	791292-2225	890	540	145	122	227	300	532	63	66
100	4"	34	34	34	34	34	34	791292-3225	1050	640	200	122	252	344	576	75	86
150	6"	6	-	10	5	10	5	791292-2240	890	540	145	168	293	366	644	63	128
150	6"	23	17	34	22	34	22	791292-3240	1050	640	200	168	318	410	688	75	148
150	6"	34	34	34	34	34	34	791392-4240	1520	965	260	168	346	449	727	100	205
200	8"	7	5	12	7	12	7	791292-3250	1050	640	200	226	368	460	796	75	253
200	8"	18	14	27	19	28	19	791392-4250	1520	965	260	226	396	499	835	100	310
200	8"	28	19	28	19	28	19	791392-4550	1665	965	395	226	396	499	835	100	355
250	10"	9	6	14	9	14	9	791392-4260	1520	965	260	264	449	552	926	100	437
250	10"	14	9	14	9	14	9	791392-4560	1665	965	395	264	449	552	926	100	482
250	10"	30	30	30	30	30	30	791392-5260	2210	1370	395	264	503	651	1025	150	822
300	12"	-	-	7	-	7	-	791392-4270	1520	965	260	311	543	646	1067	100	554
300	12"	7	-	7	-	7	-	791392-4570	1665	965	395	311	543	646	1067	100	599
300	12"	22	18	25	24	25	24	791392-5270	2210	1370	395	311	561	709	1130	150	939
350	14"	13	10	20	13	21	13	791392-5290	2210	1370	395	344	649	797	1251	150	1094
400	16"	8	6	13	8	13	8	791392-5200	2210	1370	395	384	700	848	1342	150	1298

¹ Applies to average weight of a PN40 valve + NAF Turnex actuator

² Including all direct mounted Flowserve positioners (NAF 37-series, NAF-LinkIT, PMV P5/EP5, PMV D3, PMV D20, Logix 520 MD Plus) that don't require mounting brackets

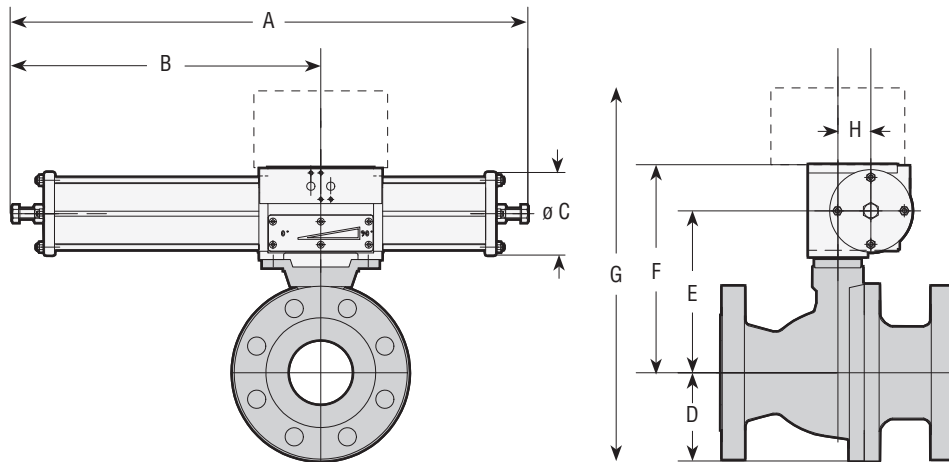

NAF791294/791394

Table 8b: NAF Duball valves with NAF Turnex pneumatic actuators (spring to open)

The below stated dP apply for clean media type water 20 °C. For other media contact NAF, see also page 8.

DN	Size	Max dP bar at supply of						NAF No.	Dimensions, mm								Weight kg ¹
		4 bar		5 bar		6 bar			A	B	C	D	E	F	G ²	H	
		R-PTFE Alloy 6	R-PTFE Alloy 6	R-PTFE Alloy 6	R-PTFE Alloy 6	R-PTFE Alloy 6	R-PTFE Alloy 6										
Single-acting, spring to open as per Fk 74.59																	
25	1"	37	18	50	47	50	50	791394-0216	455	270	80	62	134	185	357	31	13
40	1.5"	18	10	43	29	43	32	791394-0216	455	270	80	75	142	193	378	31	17
40	1.5"	37	22	50	50	50	50	791294-1216	635	390	100	75	147	203	388	40	21
50	2"	10	6	25	19	25	21	791394-0220	455	270	80	83	157	208	401	31	20
50	2"	21	14	50	40	50	50	791294-1220	635	390	100	83	162	218	411	40	24
80	3"	5	-	14	9	14	12	791294-1225	635	390	100	107	193	249	466	40	40
80	3"	26	18	50	44	50	50	791294-2225	890	540	145	107	212	285	502	63	54
100	4"	-	-	7	-	7	-	791294-1225	635	390	100	122	208	264	496	40	52
100	4"	14	8	34	22	34	28	791294-2225	890	540	145	122	227	300	532	63	66
100	4"	34	30	34	34	34	34	791294-3225	1050	640	200	122	252	344	576	75	86
150	6"	-	-	9	5	10	7	791294-2240	890	540	145	168	293	366	644	63	128
150	6"	13	8	34	21	34	28	791294-3240	1050	640	200	168	318	410	688	75	148
150	6"	27	17	34	34	34	34	791394-4240	1520	965	260	168	346	449	727	100	205
150	6"	34	34	34	34	34	34	791394-4540	1665	965	395	168	346	449	727	100	150
200	8"	-	-	11	7	12	10	791294-3250	1050	640	200	226	368	460	796	75	253
200	8"	8	5	24	17	29	24	791394-4250	1520	965	260	226	396	499	835	100	310
200	8"	29	24	29	24	29	24	791394-4550	1665	965	395	226	396	499	835	100	355
250	10"	-	-	13	7	15	11	791394-4260	1520	965	260	264	449	552	926	100	437
250	10"	15	11	15	11	15	11	791394-4560	1665	965	395	264	449	552	926	100	482
250	10"	22	14	30	30	30	30	791394-5260	2210	1370	395	264	503	651	1025	150	822
300	12"	-	-	6	-	8	5	791394-4270	1520	965	260	311	543	646	1067	100	554
300	12"	8	5	8	5	8	5	791394-4570	1665	965	395	311	543	646	1067	100	599
300	12"	11	6	25	21	25	25	791394-5270	2210	1370	395	311	561	709	1130	150	939
350	14"	6	-	19	12	22	17	791394-5290	2210	1370	395	344	649	797	1251	150	1094
400	16"	-	-	11	7	14	11	791394-5200	2210	1370	395	384	700	848	1342	150	1298

¹ Applies to average weight of a PN40 valve + NAF Turnex actuator

² Including all direct mounted Flowserve positioners (NAF 37-series, NAF-LinkIT, PMV P5/EP5, PMV D3, PMV D20, Logix 520 MD Plus) that don't require mounting brackets

Actuators

The pneumatic actuators NAF Turnex can be directly mounted to the NAF Duball DL without any couplings or brackets. Together with the direct mounting capabilities of all NAF positioners and several of the Flowserve positioners (PMV P5/EP5, PMV D3/D20 and Logix 520 MD+), this provides a high performance, vibration resistant and compact valve package suitable for precision control.

Please see data sheet for further information on the NAF Turnex actuator capabilities and all other available accessories.

Product Code for NAF Duball DL

Example:

88 8 4 K F - 0006 - BAB A E A - L
Code 1 2 3 4 5 6 7 8 9 10 11

1. **Valve type**
88 NAF Duball DL
Z-88 NAF Duball DL with Z-trim option ¹
2. **Material**
6 WCB (~EN 1.0619)
8 **CF8M (~EN 1.4408)**
 For other materials, please see ²
3. **Pressure rating**
2 PN 10 (DN 200–400) ³
3 PN 16 (DN 80–400)
4 ANSI Class 150 (Size 1”–16”)
5 PN 25 (DN 200–400) ³
6 PN 40 (DN 25–400)
7 ANSI Class 300 (Size 1”–16”)
4. **Stem bearing**
K R-PTFE, Carbon reinforced
5. **Body type**
F Flanged
6. **Size**

PN ratings		ANSI ratings		Size
	DN			
0025	25	0001		1”
0040	40	01.5		1.5”
0050	50	0002		2”
0080	80	0003		3”
0100	100	0004		4”
0150	150	0006		6”
0200	200	0008		8”
0250	250	0010		10”
0300	300	0012		12”
0350	350	0014		14”
0400	400	0016		16”
7. **Seat, ball and ball overlay**

	Seat	Ball	Overlay
AAA	R-PTFE, carbon reinforced	CF8M / 316 (~EN 1.4408)	-
BAB	Alloy 6 overlay/SS	CF8M / 316 (~EN 1.4408)	Hard Chrome
BAC	Alloy 6 overlay/SS	CF8M / 316 (~EN 1.4408)	Electroless Nickel
BAD	Alloy 6 overlay/SS	CF8M / 316 (~EN 1.4408)	Alloy 6
BBA	Alloy 6 overlay/SS	Solid Alloy 6	-

 For other materials for the ball, please see ²
8. **Seat seal**
A R-PTFE, carbon reinforced, max t=250 °C
B EPDM O-ring (for options E and T), max t=130 °C
C FPM O-ring (for options E and T), max t=130 °C
E PFM O-ring (for options E and T), max t=250 °C
H H-ELAST (same media resistance as EPDM), max t=250 °C
9. **Stem seal**
E Spring loaded R-PTFE V-rings, carbon reinforced
F Spring loaded graphite + R-PTFE V-rings, carbon reinforced
10. **Stem material**
A Duplex EN 1.4460 (~AISI 329)
11. **Options ⁴**
C Ball with straight cylindrical flow path, solid ball DN300–400 / 12”–16”
D Degreased for oxygen service
E Spring loaded seats, O-rings
L Locked seats
S Scraper seat
T Sealed seat
W Spring loaded seats, wave springs
XA ATEX certified
Z Firesafe approved design

Versions marked in bold text are the standard versions with shortest leadtime.

¹ Sizes DN50–400 / 2”–16”

² For material CF8, CF3M, CG3M, CG8M, Duplex EN 1.4470, CW-12MW, 904L, M35-01, CK3MCuN, titanium B367 Grade C2, 904L etc, please contact Flowserve NAF

³ Sizes 25–50 have the same dimensions in PN 10, PN 16, PN 25 and PN 40. Choose PN 40 for these sizes.

Sizes 80–150 have the same dimensions in PN 10 and PN 16. Choose PN 16 for these sizes.

Sizes 80–150 have the same dimensions in PN 25 and PN 40. Choose PN 40 for these sizes.

⁴ If a combination of several options is specified, please add them to a multi-sign code in alphabetic order



NAF AB
SE-581 87 Linköping
Sweden
Telephone: +46 13 31 61 00
Fax: +46 13 13 60 54
E-mail: salesnaf@flowserve.com
Website: www.flowserve.com
www.naf.se

NFENTB4167-01-A4 December 2014

To find your local Flowserve representative
or for more information about Flowserve Corporation,
visit www.flowserve.com or call USA 1 800 225 6989

Flowserve Corporation has established industry leadership in the design and manufacture of its products. When properly selected, this Flowserve product is designed to perform its intended function safely during its useful life. However, the purchaser or user of Flowserve products should be aware that Flowserve products might be used in numerous applications under a wide variety of industrial service conditions. Although Flowserve can (and often does) provide general guidelines, it cannot provide specific data and warnings for all possible applications. The purchaser/user must therefore assume the ultimate responsibility for the proper sizing and selection, installation, operation, and maintenance of Flowserve products. The purchaser/user should read and understand the Installation Operation Maintenance (IOM) instructions included with the product, and train its employees and contractors in the safe use of Flowserve products in connection with the specific application.

While the information and specifications contained in this literature are believed to be accurate, they are supplied for informative purposes only and should not be considered certified or as a guarantee of satisfactory results by reliance thereon. Nothing contained herein is to be construed as a warranty or guarantee, express or implied, regarding any matter with respect to this product. Because Flowserve is continually improving and upgrading its product design, the specifications, dimensions and information contained herein are subject to change without notice. Should any question arise concerning these provisions, the purchaser/user should contact Flowserve Corporation at any one of its worldwide operations or offices.

© 2014 Flowserve Corporation, Irving, Texas, USA. Flowserve is a registered trademark of Flowserve Corporation.