



## OPTIFLEX 1300 C Technical Datasheet

Guided Radar (TDR) Level Transmitter for heavy-duty and interface applications

- Universal device that can measure level of liquids, pastes, granulates, powders, and liquid interface
- Easy to install: on-site calibration is not needed
- Operates up to 300 bar / 4350 psi



<b>1</b>	<b>Product features</b>	<b>3</b>
<hr/>		
1.1	The superior TDR solution .....	3
1.2	Applications .....	5
1.3	Application table for probe selection .....	8
1.4	Measuring principle.....	9
<b>2</b>	<b>Technical data</b>	<b>12</b>
<hr/>		
2.1	Technical data.....	12
2.2	Pressure/temperature table for probe selection .....	18
2.3	Guidelines for maximum operating pressure (CRN certification) .....	19
2.4	Measurement limits .....	23
2.5	Dimensions and weights .....	26
<b>3</b>	<b>Installation</b>	<b>40</b>
<hr/>		
3.1	Intended use .....	40
3.2	Pre-installation requirements .....	40
3.3	How to prepare the tank before you install the device .....	41
3.3.1	General information for nozzles .....	41
3.3.2	Installation requirements for concrete roofs.....	43
3.3.3	Recommendations for pits and tanks made of non-conductive materials.....	43
3.4	Installation recommendations for liquids.....	44
3.4.1	General requirements .....	44
3.4.2	Standpipes.....	45
3.5	Installation recommendations for solids .....	49
3.5.1	Nozzles on conical silos.....	49
3.5.2	Traction loads on the probe.....	50
<b>4</b>	<b>Electrical connections</b>	<b>51</b>
<hr/>		
4.1	Electrical installation: outputs 1 and 2 .....	51
4.1.1	Non-Ex devices .....	51
4.1.2	Devices for hazardous locations.....	52
4.2	Protection category .....	52
4.3	Networks .....	53
4.3.1	General information.....	53
4.3.2	Point-to-point networks .....	53
4.3.3	Multi-drop networks .....	54
<b>5</b>	<b>Order information</b>	<b>55</b>
<hr/>		
5.1	Order code .....	55
<b>6</b>	<b>Notes</b>	<b>66</b>
<hr/>		

## 1.1 The superior TDR solution

This device is a Guided Radar (TDR) Level Transmitter for measuring distance, level, interface, level and interface, volume and mass. It has higher signal dynamics and a sharper pulse than conventional TDR devices and therefore better reproducibility and accuracy. A variant with a remote converter can be mounted up to 14.5 m / 47.6 ft from the probe. The device can operate at very low and very high process temperatures as long as the process connection temperature limits are observed.

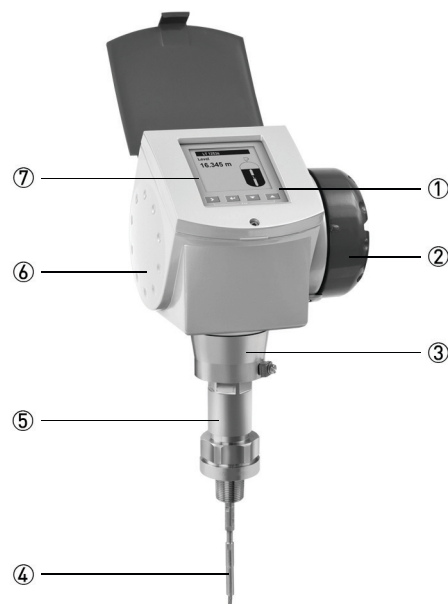

- ① Touch screen with 4-button operation
- ② 2-wire level meter
- ③ Converter is rotatable and removable under process conditions
- ④ 5 different types of probes suitable for a wide range of media
- ⑤ Optional ESD protection (30 kV) or Metaglas® dual process sealing system for dangerous products
- ⑥ Same converter for Ex and non-Ex
- ⑦ Large graphical display

### Highlights

- Displays level and interface
- PACTware and DTMs included as standard
- Optional second current output – used for displaying interface measurements, for example
- High-pressure and high-temperature versions
- Optimal process safety (with Metaglas® dual process sealing system for dangerous products)
- Display in 9 languages: even in Chinese, Japanese and Russian
- Available in stainless steel and HASTELLOY® C-22®. Other materials are available on request: monel, tantalum, titanium, duplex etc.
- Angled single cable and rod probes are available on request for installation in tanks which contain obstructions

### Industries

- Chemicals & Petrochemicals
- Oil & Gas
- Minerals & Mining
- Wastewater
- Pulp & Paper
- Food & Beverages
- Pharmaceutical
- Energy

### Applications

- Blending tanks
- Distillation tanks
- Process tanks
- Separator
- Solid silos (inventory)
- Storage tanks

## 1.2 Applications

### 1. Level measurement of liquids

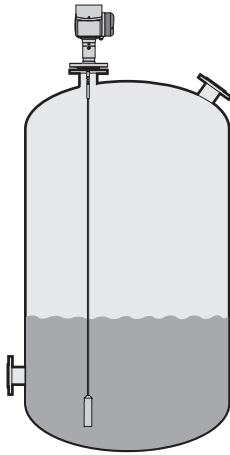

The level transmitter can measure the level of a wide range of liquid products on a large variety of installations within the stated pressure and temperature range, including LPG and LNG. It does not require calibration or commissioning when installed. A Metaglas® option is also available for dangerous products and ensures that no leakage is possible.

A number of probe end attachments are available. For example, the user can fix the end of cable probes to heating coils: the heat prevents deposits building up on the probe.

### 2. Interface measurement of liquids

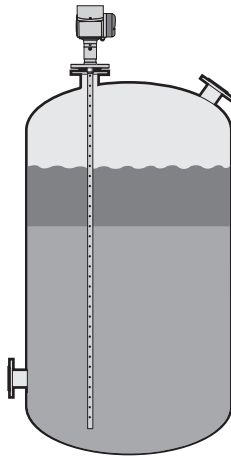

The level transmitter can measure interface with or without an air gap. It can also measure level and interface simultaneously. It has an optional second analogue output.

The coaxial probe of the level transmitter has a top dead zone of only 35 mm / 1.4": this makes it ideal for tracking full tank or ballast interface.

### 3. Level measurement of solids

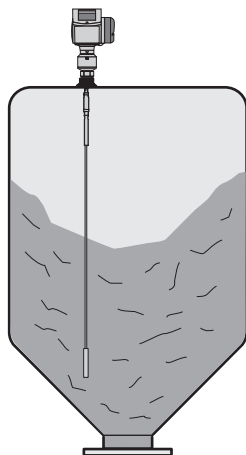

The level transmitter has a strengthened  $\varnothing 8$  mm / 0.3" single cable probe for measuring powders and granulates in silos up to 35 m / 115 ft high.

The  $\varnothing 4$  mm / 0.15" single cable probe is used for small silos. An ESD protection (30 kV) option is also available.

If a product has a very low dielectric constant ( $\epsilon_r < 1.6$ ), the level transmitter automatically switches to TBF (Tank Bottom Following) mode and keeps operating.

### 4. Measurement of liquids in a bypass chamber

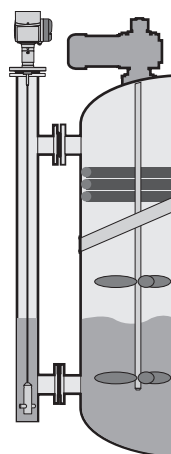

The level transmitter can measure accurately in agitated conditions and in the presence of foam. If the tank is full of obstructions such as agitators and reinforcements, we recommend installing the level transmitter in a bypass chamber. This solution is available from KROHNE under the name BM 26 F. Please refer to the BM 26 F documentation for further information.

## 5. Measurement of liquids in a still well

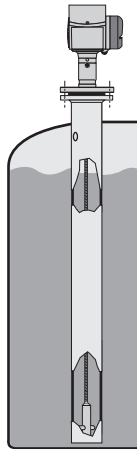

You can also install the level transmitter in a still well if there are vortices, agitators or other obstructions in the tank. It is also suitable for tanks with floating roofs. The level transmitter's setup wizard allows you to quickly configure your device to suit specific types of installations and get the best possible performance from it.

## 6. Remote display on high or inaccessible tanks

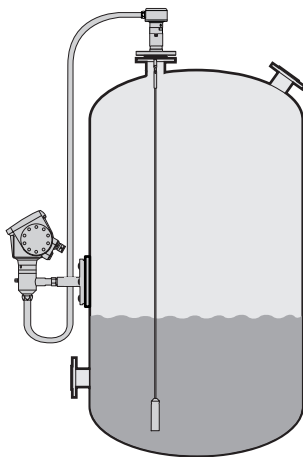

If it is difficult or impossible to read the level transmitter's integrated display at the top of the tank, we recommend the remote display variant. It is provided with a cable up to 14.5 m / 47.6 ft long and a bracket for mounting in an accessible position. If there is vibration in the installation, we also recommend that you attach the remote converter to a wall or another safe object that is not attached to the installation.

### 1.3 Application table for probe selection

	Double rod	Single rod	Single rod (segmented)	Coaxial	Coaxial (segmented)	Double cable	Single cable Ø8 mm / 0.32"	Single cable Ø4 mm / 0.16"	Single cable Ø2 mm / 0.08"
--	------------	------------	------------------------	---------	---------------------	--------------	----------------------------	----------------------------	----------------------------

#### Maximum probe length, L

4 m / 13 ft	■	■							
6 m / 20 ft			■	■	■				
8 m / 26 ft						■			
35 m / 115 ft							■	■	■

#### Liquids

Liquid application	■	■	■	■	■	■	■	■	■
LPG, LNG	■			■	■			①	①
Highly viscous liquids		■	■					■	■
Highly crystallising liquids		■	■					■	■
Highly corrosive liquids	■	■	■	■	■			■	■
Foam		■	■	■	■			■	■
Agitated liquids	■	②	②	■	■	②		②	②
High-pressure applications	③	③	③	③	③	③		③	④
High-temperature applications									⑤
Spray in tank		①	①	■	■			①	①
Storage tanks	■	■	■	■	■	■		■	■
Installation in bypass chamber	■	■		■	■	■		■	■
Small diameter nozzles	■			■	■	■			
Long nozzles	■			■	■	■			
Stilling wells	■	■	■	■	■	■		■	■
Interface measurement	■			■	■	■		⑥	⑥

#### Solids

Powders		■	■					⑦	
Granules, <5 mm / 0.1"								⑦	

■ standard ■ optional □ on request

- ① Install the device in a stilling well or a bypass chamber
- ② Use this probe with an anchor fitting. For more data, refer to the handbook.
- ③ Max. pressure is 100 bar / 1450 psig. Refer to the pressure-temperature table for probe selection.
- ④ Optional. Max. pressure is 300 bar / 4350 psig. Refer to the pressure-temperature table for probe selection.
- ⑤ Optional. Max. temperature is 300°C / 570°F. Refer to the pressure-temperature table for probe selection.
- ⑥ Max. length is 20 m / 65.5 ft, more on request
- ⑦ Max. length is 10 m / 33 ft, more on request



## 1.4 Measuring principle

This Guided Radar (TDR) level meter has been developed from a proven technology called Time Domain Reflectometry (TDR).

The device transmits low-intensity electromagnetic pulses of approximately half a nanosecond width along a rigid or flexible conductor. These pulses move at the speed of light. When the pulses reach the surface of the product to be measured, the pulses are reflected with an intensity that depends on the dielectric constant,  $\epsilon_r$ , of the product (for example, water has a high dielectric constant and reflects the pulse back to the meter converter at 80% of its original intensity).

The device measures the time from when the pulse is emitted to when it is received: half of this time is equivalent to the distance from the reference point of the device (the flange facing) to the surface of the product. The time value is converted into an output current of 4...20 mA and/or a digital signal.

Dust, foam, vapor, agitated surfaces, boiling surfaces, changes in pressure, changes in temperature and changes in density do not have an effect on device performance.

The illustration that follows shows a snapshot of what a user would see on an oscilloscope, if the level of one product is measured.

## Level measurement principle (direct mode)

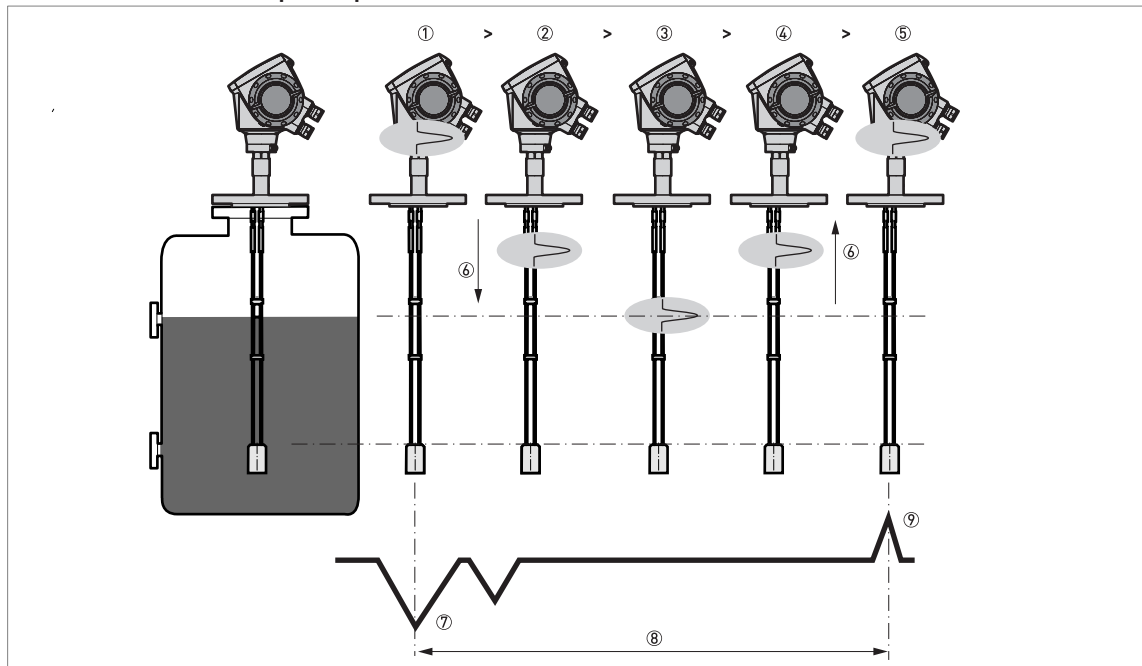

Figure 1-1: Level measurement principle

- ① Time 0: The electromagnetic (EM) pulse is transmitted by the converter
- ② Time 1: The pulse goes down the probe at the speed of light in air,  $V_1$
- ③ Time 2: The pulse is reflected
- ④ Time 3: The pulse goes up the probe at speed,  $V_1$
- ⑤ Time 4: The converter receives the pulse and records the signal
- ⑥ The EM pulse moves at speed,  $V_1$
- ⑦ Transmitted EM pulse
- ⑧ Half of this time is equivalent to the distance from the reference point of the device (the flange facing) to the surface of the product
- ⑨ Received EM pulse

The illustration that follows shows a snapshot of what a user would see on an oscilloscope, if the level and/or interface of products are measured.

**Interface measurement:** *The dielectric constant of the top liquid must be less than the dielectric constant of the bottom liquid. If not, or if there is too small a difference, the device may not measure correctly.*

## Level and interface measurement principle (direct measurement)

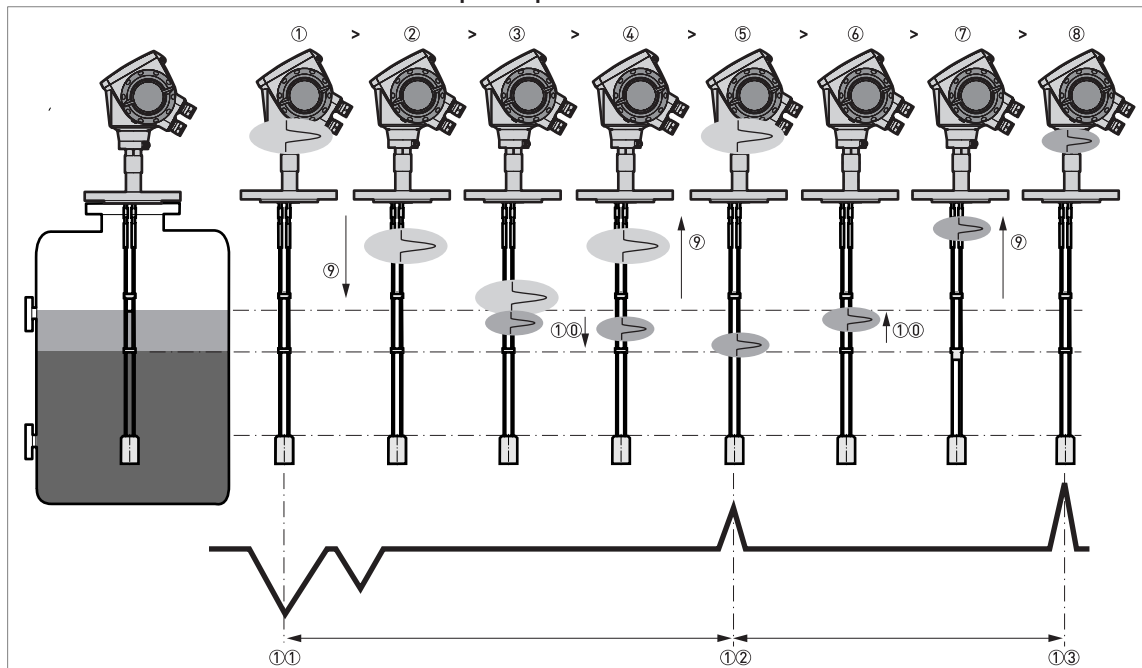

Figure 1-2: Level and interface measurement principle (2 liquids in the tank)

- ① Time 0: The electromagnetic (EM) pulse is transmitted by the converter
- ② Time 1: The pulse goes down the probe at the speed of light in air,  $V_1$
- ③ Time 2: Part of the pulse is reflected at the surface of the top liquid, the remaining pulse goes down the probe
- ④ Time 3: Part of the pulse goes up the probe at speed,  $V_1$ . The remaining pulse goes down the probe at the speed of light in the top product,  $V_2$
- ⑤ Time 4: The converter receives part of the pulse and records the signal. The remaining pulse is reflected at the interface of the 2 liquids
- ⑥ Time 5: The remaining pulse goes up the probe at speed,  $V_2$
- ⑦ Time 6: The remaining pulse goes up the probe at speed,  $V_1$
- ⑧ Time 7: The converter receives the remaining pulse and records the signal
- ⑨ The EM pulse moves at speed,  $V_1$
- ⑩ The EM pulse moves at speed,  $V_2$
- ⑪ Transmitted EM pulse
- ⑫ Received EM pulse (distance to the top liquid)
- ⑬ Received EM pulse (distance to the interface of 2 liquids)

If products have a very low dielectric constant ( $\epsilon_r < 1.6$ ), only a small part of the EM pulse is reflected at the surface of the product. Most of the pulse is reflected at the probe end. TBF (tank bottom following) mode is used to measure the distance to the product surface.

TBF mode (indirect measurement) compares:

- The time for the pulse to go to the probe end and go back to the converter when the tank is empty.
- The time for the pulse to go to the probe end and go back to the converter when the tank is full or partially filled.

The level of the product in the tank can be calculated from the time difference.

## 2.1 Technical data

- The following data is provided for general applications. If you require data that is more relevant to your specific application, please contact us or your local sales office.
- Additional information (certificates, special tools, software,...) and complete product documentation can be downloaded free of charge from the website (Downloadcenter).

### Measuring system

Measuring principle	2-wire loop-powered level transmitter; Time Domain Reflectometry (TDR)
Application range	Level measurement of liquids, pastes, slurries, powders and granulates
Primary measured value	Time between the emitted and received signal
Secondary measured value	Distance, level, volume, mass and/or interface

### Design

Construction	The measurement system consists of a measuring sensor (probe) and a signal converter which is available in a compact or remote version
Options	Integrated LCD display with sun cover (-20...+60°C / -4...+140°F); if the ambient temperature is not in these limits, the display switches off
	2nd current output
	ESD protection (max. 30 kV)
	Metaglas® (dual process sealing system for dangerous products (ammonia, chlorine, ...)) ①
	Remote housing connected to the probe via a flexible conduit Standard lengths: 2 m / 6.6 ft, 4.5 m / 14.8 ft, 9.5 m / 31.2 ft and 14.5 m / 47.6 ft
	<b>Probe end types (not for rod and coaxial probes)</b> Standard: Counterweights (refer to counterweight dimensions in "Technical data: Dimensions and weights") Options: Turnbuckle, chuck, threaded end, crimped end, open end
Accessories	Weather protection
	Discs (low-pressure flanges) with bolt hole dimensions and positions that agree with DN80...200 in PN06 or 3" ...8" in 150 lb for devices with the G 1½ threaded connection. Max. pressure: 1 barg / 14.5 psig at +20°C / +68°F.
Max. measuring range	Double rod Ø8 mm / 0.32": 4 m / 13 ft
	Single rod Ø8 mm / 0.32": 4 m / 13 ft
	Single rod Ø8 mm / 0.32" (segmented): 6 m / 20 ft
	Coaxial Ø22 mm / 0.87": 6 m / 20 ft
	Coaxial Ø22 mm / 0.87" (segmented): 6 m / 20 ft
	Double cable Ø4 mm / 0.16": 8 m / 26 ft
	Single cable Ø2 mm / 0.08": 35 m / 115 ft (for liquids only)
	Single cable Ø4 mm / 0.16": 35 m / 115 ft (an angled probe is available on request for installations with very low ceilings or objects in the tank that prevent installation on top of the tank)
	Single cable Ø8 mm / 0.32": 35 m / 115 ft (for solids only)
Tolerance, probe length	±0.5%
Dead zone	This depends on the type of probe. For more data, refer to <i>Measurement limits</i> on page 23.

Display and User interface	
Display	LCD display
	9 lines, 160×160 pixels in 8-step grayscale with 4-button keypad
Interface languages	English, German, French, Italian, Spanish, Portuguese, Japanese, Simplified Chinese and Russian

### Accuracy

Resolution	1 mm / 0.04"
Repeatability	±1 mm / ±0.04"
Accuracy (in direct mode)	<b>Liquids:</b> ±3 mm / ±0.12", when distance < 10 m / 33 ft; ±0.03% of measured distance, when distance > 10 m / 33 ft
	<b>Powders:</b> ±20 mm / ±0.8"
	<b>Interface:</b> ±10 mm / ±0.4" ( $\epsilon_r$ constant)
Accuracy (in TBF mode)	±20 mm / ±0.8" ( $\epsilon_r$ constant)
Minimum layer (interface)	50 mm / 2"
<b>Reference conditions acc. to EN 60770</b>	
Temperature	+20°C ±5°C / +68°F ±10°F
Pressure	1013 mbara ±20 mbar / 14.69 psia ±0.29 psi
Relative air humidity	60% ±15%

### Operating conditions

Temperature	
Ambient temperature	-40...+80°C / -40...+176°F Ex: see supplementary operating instructions or approval certificates
Storage temperature	-40...+85°C / -40...+185°F
Process connection temperature	<b>Standard</b> -50...+200°C / -58...+392°F (according to the temperature limits of the gasket material. Refer to "Material" in this table.) Ex: see supplementary operating instructions or approval certificates ②
	<b>High-Temperature (HT) and High-Temperature / High-Pressure (HT/HP) versions with FKM/FPM and Kalrez® 6375 gaskets</b> +300°C / +572°F (single cable Ø2 mm / 0.08" probe only) Ex: see supplementary operating instructions or approval certificates ②
	<b>HT and HT/HP versions with EPDM gaskets</b> +250°C / +482°F (single cable Ø2 mm / 0.08" probe only) Ex: see supplementary operating instructions or approval certificates ②
Pressure	
Operating pressure	<b>Single cable Ø8 mm / 0.32" probe</b> -1...40 barg / -14.5...580 psig subject to process connection temperature and probe type used ②
	<b>High-Pressure (HP) version</b> max. 300 barg / 4350 psig (single cable Ø2 mm / 0.08" probe only) subject to process connection temperature and probe type used ②
	<b>All other probe types</b> -1...100 barg / -14.5...1450 psig subject to process connection temperature and probe type used ②

Other conditions	
Dielectric constant ( $\epsilon_r$ )	<b>Level in direct mode:</b> $\geq 1.4$ for coaxial probe; $\geq 1.6$ for single and double probes
	<b>Interface in direct mode:</b> $\epsilon_r(\text{interface}) \gg \epsilon_r(\text{level})^2$
	<b>Level in TBF mode:</b> $\geq 1.1$
Vibration resistance	IEC 60068-2-6 and EN 50178 (10...57 Hz: 0.075 mm / 57...150 Hz:1g)
Protection category	IP 66/67 equivalent to NEMA 4X (housing) and 6P (probe)

### Installation conditions

Process connection size	Refer to "Installation: How to prepare the tank before you install the device" and "Technical data: Measurement limits"
Process connection position	Make sure that there are not any obstructions directly below the process connection for the device.
Dimensions and weights	Refer to "Technical data: Dimensions and weights"

### Material

Housing	Standard: Polyester-coated aluminium
	Option: Stainless steel (1.4404 / 316L) ③
Single rod (single-piece)	Standard: Stainless steel (1.4404 / 316L)
	Option: Stainless steel (1.4404 / 316L) in a PVDF protective sheath, HASTELLOY® C-22® (2.4602) ④
	On request: Stainless steel (1.4404 / 316L) in a PVC or PP protective sheath
	On request: Monel; Tantalum; Titanium; Duplex
Single rod (segmented)	Standard: Stainless steel (1.4404 / 316L)
Double rod	Standard: Stainless steel (1.4404 / 316L)
	Option: HASTELLOY® C-22® (2.4602)
	On request: Monel; Tantalum; Titanium; Duplex
Coaxial (single-piece)	Standard: Stainless steel (1.4404 / 316L)
	Option: HASTELLOY® C-22® (2.4602)
Coaxial (segmented)	Standard: Stainless steel (1.4404 / 316L)
Single cable	Standard: Stainless steel (1.4401 / 316)
	Option: HASTELLOY® C-22® (2.4602) – only for the $\varnothing 2$ mm / 0.08" single cable probe
	On request: FEP-coated stainless steel (-20...+150°C / -4...+302°F) – only for the $\varnothing 4$ mm / 0.16" single cable probe
Double cable	Stainless steel (1.4401 / 316)
Process fitting	Standard: Stainless steel (1.4404 / 316L)
	Option: HASTELLOY® C-22® (2.4602)
	On request: Monel; Tantalum; Titanium; Duplex
Gaskets	FKM/FPM (-40...+200°C / -40...+392°F); Kalrez® 6375 (-20...+200°C / -4...+392°F); EPDM (-50...+150°C / -58...+302°F) – all probes except single cable $\varnothing 8$ mm / 0.32" ⑤
Weather protection (Option)	Stainless steel (1.4301 / 304)
Protective sheath (On request for single rod only)	PP (-40...+90°C / -40...+194°F); PVC (-15...+80°C / +5...+176°F); PVDF (-40...+150°C / -40...+302°F)
Conduit for remote housing (Option)	Zinc-coated steel in a PVC sheath (-40...+105°C / -40...+221°F)

## Process connections

Thread	
Single cable Ø2 mm / 0.08"	G ½ (ISO 228); ½ NPT (ASME B1.20.1); ½ NPTF (ASME B1.20.3 – for the HT/HP version)
Single cable Ø8 mm / 0.32" Double cable Ø4 mm / 0.16" Double rod Ø8 mm / 0.32"	G 1½ (ISO 228); 1½ NPT (ASME B1.20.1)
All other probes	G ¾...1½ (ISO 228); ¾...1½ NPT (ASME B1.20.1)
Flange versions for double rod and double cable probes	
EN 1092-1	DN50...80 in PN40 (Type B1), DN100...200 in PN16 or PN40 (Type B1), DN50...150 in PN63 or PN100 (Type B1); others on request Optional flange facing: Types C, D, E and F
ASME B16.5	2"...8" in 150 lb, 2"...6" in 300 lb RF, 2"...4" in 600 lb RF; 3"...4" 900 lb RF, 2" in 900 lb or 1500 lb RJ; others on request Optional flange facing: RJ (Ring Joint)
JIS B2220	50...100A in 10K; others on request
Flange versions for single cable Ø8 mm / 0.32" cable probes	
EN 1092-1	DN40...80 in PN40 (Type B1), DN100...200 in PN16 or PN40 (Type B1), DN40...150 in PN63 or PN100 (Type B1); others on request Optional flange facing: Types C, D, E and F
ASME B16.5	1½"...8" in 150 lb, 1½"...6" in 300 lb RF, 1½"...4" in 600 lb RF; 3"...4" 900 lb RF, 1½"...2" in 900 lb or 1500 lb RJ; others on request Optional flange facing: RJ (Ring Joint)
JIS B2220	40...100A in 10K; others on request
Flange versions for single cable Ø2 mm / 0.08" probe	
EN 1092-1	DN25...80 in PN40 (Type B1), DN100...200 in PN16 or PN40 (Type B1), DN40...150 in PN63 or PN100 (Type B1); others on request Optional flange facing: Types C, D, E and F
ASME B16.5	1"...8" in 150 lb RF, 1½"...6" in 300 lb RF, 1"...4" in 600 lb RF, 3"...4" in 900 lb RF, 1"...2" in 900 lb or 1500 lb RJ, 1" in 2500 lb RJ; others on request Optional flange facing: RJ (Ring Joint)
JIS B2220	40...100A in 10K; others on request
Flange versions for other probes	
EN 1092-1	DN25...80 in PN40 (Type B1), DN100...200 in PN16 or PN40 (Type B1), DN25...150 in PN63 or PN100 (Type B1); others on request Optional flange facing: Types C, D, E and F
ASME B16.5	1"...8" in 150 lb RF, 1½"...6" in 300 lb RF, 1"...4" in 600 lb RF, 3"...4" in 900 lb RF, 1"...2" in 900 lb or 1500 lb RJ; others on request Optional flange facing: RJ (Ring Joint)
JIS B2220	40...100A in 10K; others on request
Other options for single and double rod probes	
SMS	Available on request
Tri-clamp	Available on request
Others	Others on request

## Electrical connections

Power supply	<b>Terminals output 1 – Non-Ex / Ex i:</b> 14...30 VDC; min./max. value for an output of 22 mA at the terminal
	<b>Terminals output 1 – Ex d:</b> 20...36 VDC; min./max. value for an output of 22 mA at the terminal
	<b>Terminals output 2 – Non-Ex / Ex i / Ex d:</b> 10...30 VDC; min./max. value for an output of 22 mA at the terminal (additional power supply needed – output only)

Cable entry	M20×1.5; ½ NPT
	G ½ (not for FM- and CSA-approved devices. Not for stainless steel housings.)
	Stainless steel housings: M20×1.5
Cable gland	Standard: none
	Options: M20×1.5; others are available on request
Cable entry capacity (terminal)	0.5...1.5 mm <sup>2</sup>

### Input and output

<b>Current output</b>	
Output signal (Output 1)	4...20 mA HART® or 3.8...20.5 mA acc. to NAMUR NE 43 ⑥
Output signal (Output 2 – optional)	4...20 mA (no HART® signal) or 3.8...20.5 mA acc. to NAMUR NE 43 (optional)
Resolution	±3 µA
Temperature drift	Typically 50 ppm/K
Error signal	High: 22 mA; Low: 3.6 mA acc. to NAMUR NE 43

### Approvals and certification

CE	This device fulfils the statutory requirements of the EC directives. The manufacturer certifies successful testing of the product by applying the CE mark.
<b>Explosion protection</b>	
ATEX KEMA 04ATEX1218 X	II 1 G, 1/2 G, 2 G Ex ia IIC T6...T2 Ga or Ex ia IIC T6...T2 Ga/Gb or Ex ia IIC T6...T2 Gb;
	II 1 D, 1/2 D, 2 D Ex ia IIIC T95°C Da or Ex ia IIIC T95°C Da/Db or Ex ia IIIC T95°C Db;
	II 1/2 G, 2 G Ex ia/d IIC T6...T2 Ga/Gb or Ex d ia IIC T6...T2 Gb;
	II 1/2 D, 2 D Ex ia tb IIIC T95°C Da/Db or Ex ia tb IIIC T95°C Db;
	II 3 G Ex nA II T6...T2 X
IECEX IECEX KEM 06.0024X	Ex ia IIC T6...T2 Ga; Ex ia IIIC T95°C Da;
	Ex ia/d IIC T6...T2 Ga/Gb; Ex ia tb IIIC T95°C Da/Db
FM – Dual Seal-approved	<b>NEC 500</b>
	XP-IS / Cl. I / Div. 1 / Gr. ABCD / T6-T1;
	DIP / Cl. II, III / Div. 1 / Gr. EFG / T6-T1;
	IS / Cl. I, II, III / Div. 1 / Gr. ABCDEFG / T6-T1;
	NI / Cl. I / Div. 2 / Gr. ABCD / T6-T1
	<b>NEC 505</b>
	Cl. I / Zone 0 / AEx d[ia] / IIC / T6-T1;
	Cl. I / Zone 0 / AEx ia / IIC / T6-T1;
	Cl. I / Zone 2 / AEx nA[ia] / IIC / T6-T1
	Hazardous (Classified) Locations, indoor/outdoor Type 4X and 6P, IP66, Dual Seal
CSA – Dual Seal-approved	<b>CEC Section 18 (Zone ratings)</b>
	Cl. I, Zone 1, Ex d, IIC (Probe: Zone 0) T6;
	Cl. I, Zone 0, Ex ia, IIC T6;
	Cl. I, Zone 2, Ex nA, IIC T6
	<b>CEC Section 18 and Annex J (Division ratings)</b>
	XP-IS, Cl. I, Div. 2, Gr. ABCD; Cl. II, Div. 2, Gr. FG; Cl. III, Div. 2 T6;
	IS, Cl. I, Div. 1, Gr. ABCD; Cl. II, Gr. FG; Cl. III T6



NEPSI GYJ111195/96	Ex d ia IIC T2~T6 DIP A21/A20 T <sub>A</sub> T70°C~T95°C IP6X;
	Ex ia IIC T2~T6 DIP A21/A20 T <sub>A</sub> T70°C~T95°C IP6X
DNV / INMETRO DNV 12.0042 X	Ex ia IIC T6...T2 Ga; Ex ia IIIC T70°C...T95°C Da IP6X;
	Ex d [ia Ga] IIC T6...T2 Ga/Gb; Ex tb [ia Da] IIIC T70°C...T95°C Db IP6X
KGS 11-GA4B0-0327X 11-GA4B0-0328X	Ex ia IIC T6~T2; Ex iaD 20 IP6X T70°C~T95°C;
	Ex d[ia] IIC T6~T2; Ex tD[iaD] A21/20 IP6X T70°C~T95°C
<b>Other standards and approvals</b>	
EMC	Electromagnetic Compatibility Directive 2004/108/EC in conjunction with EN 61326-1 (2013). The device agrees with this standard if: – the device has a coaxial probe or – the device has a single / double probe that is installed in a metallic tank.
NAMUR	NAMUR NE 21 Electromagnetic Compatibility (EMC) of Industrial Process and Laboratory Control Equipment
	NAMUR NE 43 Standardization of the Signal Level for the Failure Information of Digital Transmitters
WHG Z-65.16-460	In conformity with the German Federal Water Act, §9
CRN	This certification is for all Canadian provinces and territories. For more data, refer to the website.
Construction code	On request: NACE MR0175 / ISO 15156; NACE MR0103

- ① Metaglas® is a registered trademark of Herberts Industrieglas, GMBH & Co., KG
- ② Refer to the Pressure/Temperature table for probe selection
- ③ This option is not available for FM- or CSA-approved devices
- ④ HASTELLOY® is a registered trademark of Haynes International, Inc.
- ⑤ Kalrez® is a registered trademark of DuPont Performance Elastomers L.L.C.
- ⑥ HART® is a registered trademark of the HART Communication Foundation

## 2.2 Pressure/temperature table for probe selection

Make sure that the transmitters are used within their operating limits.

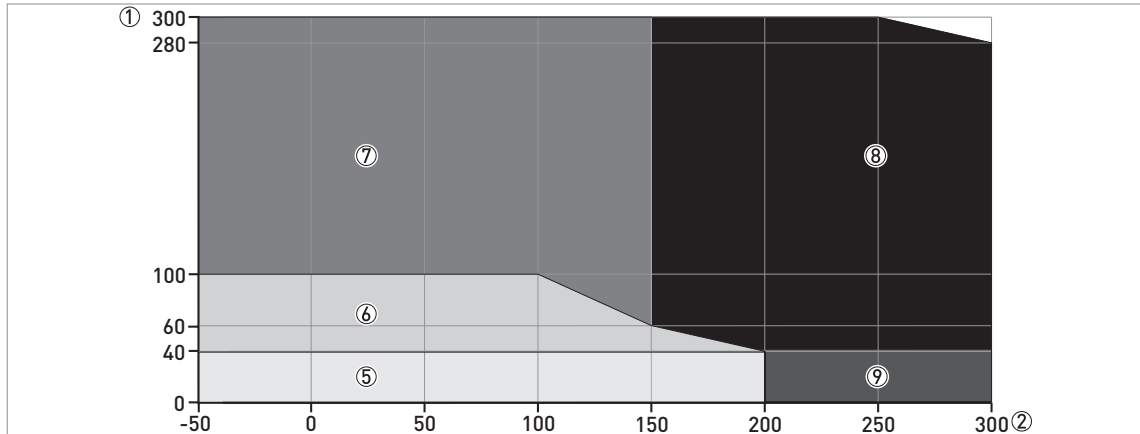

Figure 2-1: Pressure/temperature table for probe selection in °C and barg

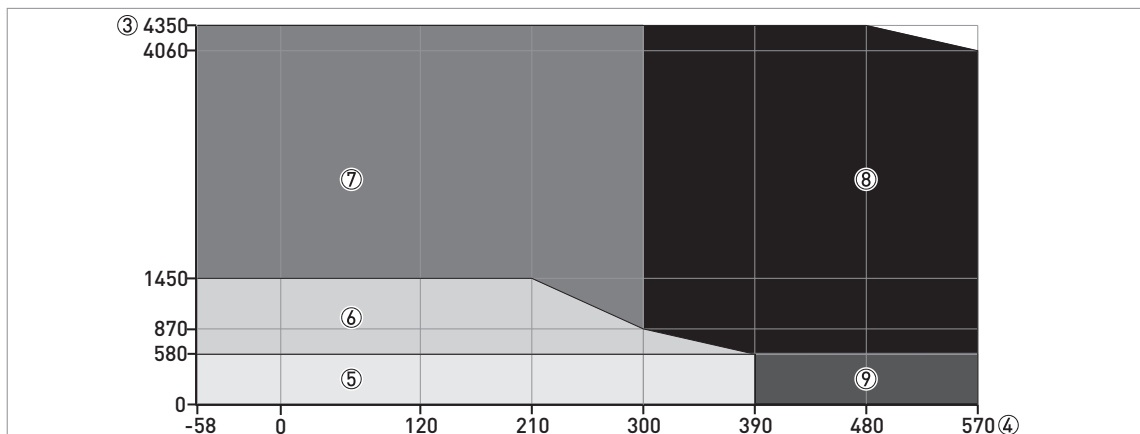

Figure 2-2: Pressure/temperature table for probe selection in °F and psig

- ① Process pressure,  $P_s$  [barg]
- ② Process connection temperature,  $T$  [°C]
- ③ Process pressure,  $P_s$  [psig]
- ④ Process connection temperature,  $T$  [°F]
- ⑤ All probes
- ⑥ All probes. This does not include the  $\varnothing 8$  mm / 0.32" single cable probe.
- ⑦ High-Pressure (HP) version of the  $\varnothing 2$  mm / 0.08" single cable probe
- ⑧ High-Temperature/High-Pressure (HT/HP) version of the  $\varnothing 2$  mm / 0.08" single cable probe
- ⑨ High-Temperature (HT) version of the  $\varnothing 2$  mm / 0.08" single cable probe

*The minimum and maximum process connection temperature and the minimum and maximum process pressure also depends on the gasket material selected. Refer to "Technical data" on page 12.*

## 2.3 Guidelines for maximum operating pressure (CRN certification)

Make sure that the devices are used within their operating limits. CRN certification is necessary for all devices that are installed on a pressure vessel and used in Canada.

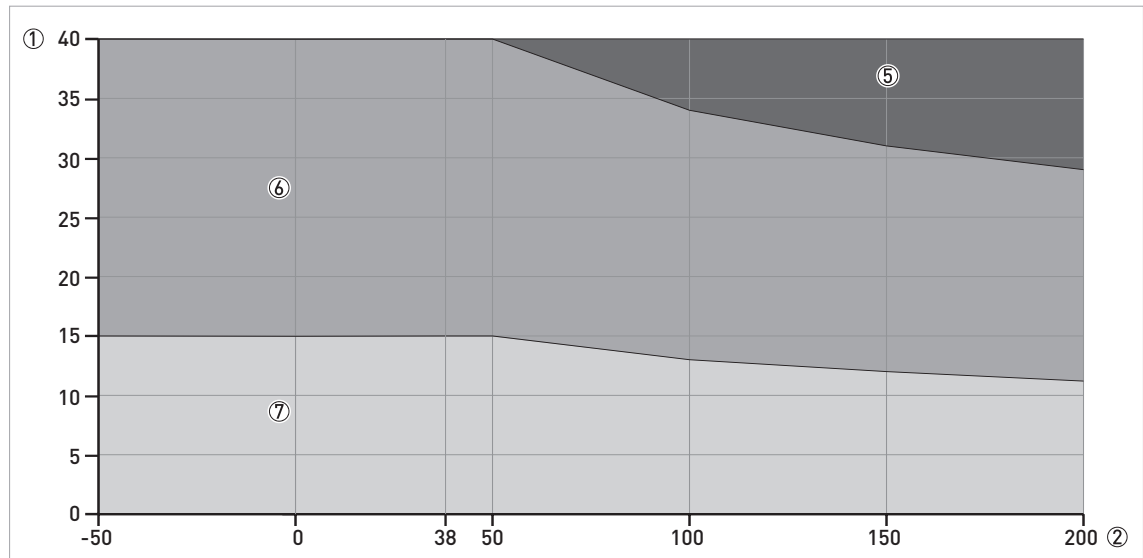

Figure 2-3: Pressure / temperature de-rating (ASME B16.5), Ø8 mm single cable probe, in °C and barg

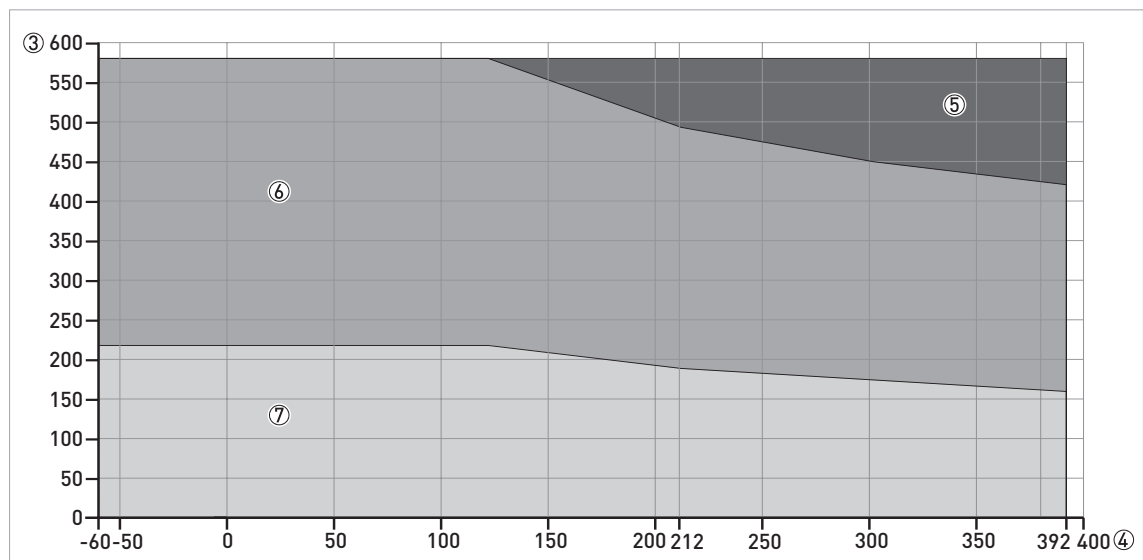

Figure 2-4: Pressure / temperature de-rating (ASME B16.5), Ø0.3" single cable probe, in °F and psig

- ① p [barg]
- ② T [°C]
- ③ p [psig]
- ④ T [°F]
- ⑤ Threaded connection, NPT (ASME B1.20.1).
- ⑥ Flange connection, Class 300 and Class 600. Threaded connection, NPT (ASME B1.20.1).
- ⑦ Flange connection, Class 150

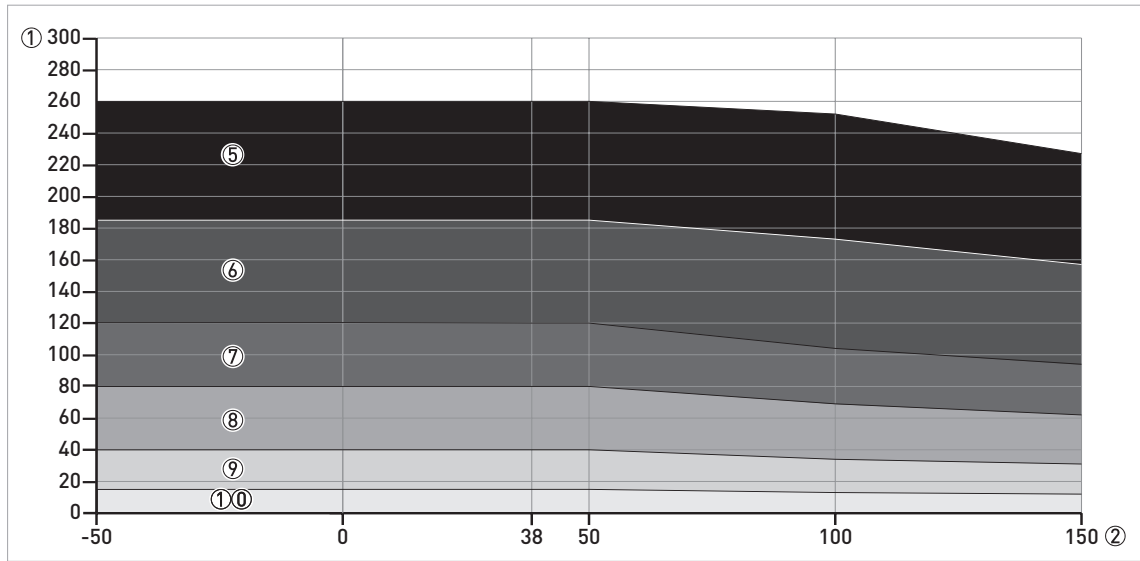

Figure 2-5: Pressure / temperature de-rating (ASME B16.5), Ø2 mm single cable probe (HP version), in °C and barg

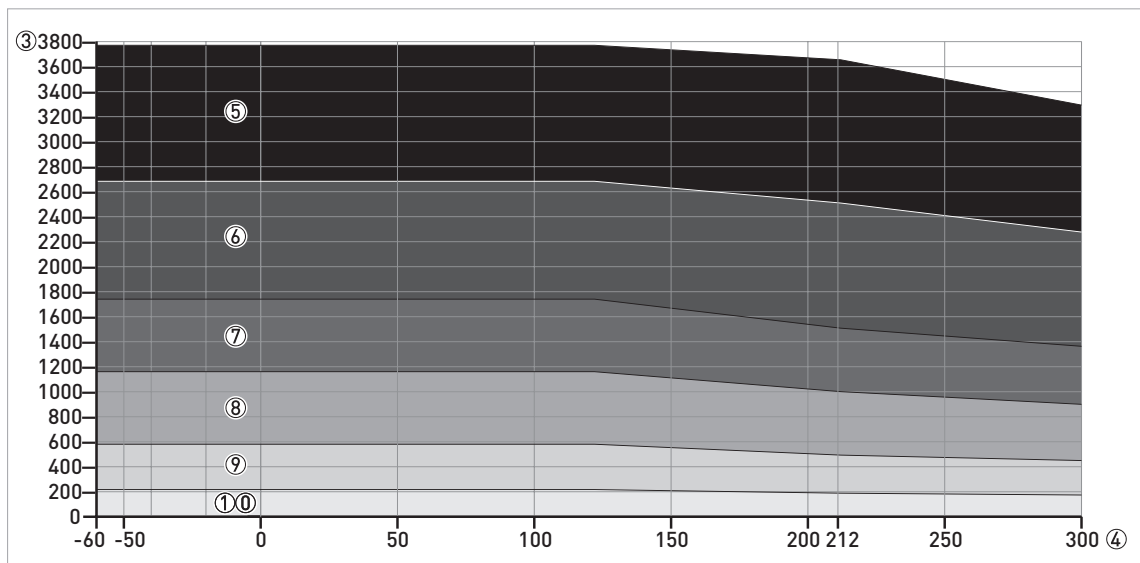

Figure 2-6: Pressure / temperature de-rating (ASME B16.5), Ø0.08" single cable probe (HP version), in °F and psig

- ① p [barg]
- ② T [°C]
- ③ p [psig]
- ④ T [°F]
- ⑤ Flange connection, Class 2500: RJ flange facing only. Threaded connection, NPTF (ASME B1.20.3).
- ⑥ Flange connection, Class 1500: RJ flange facing only
- ⑦ Flange connection, Class 900: LT, LG, ST, SG and RJ flange facings only
- ⑧ Flange connection, Class 600
- ⑨ Flange connection, Class 300
- ⑩ Flange connection, Class 150

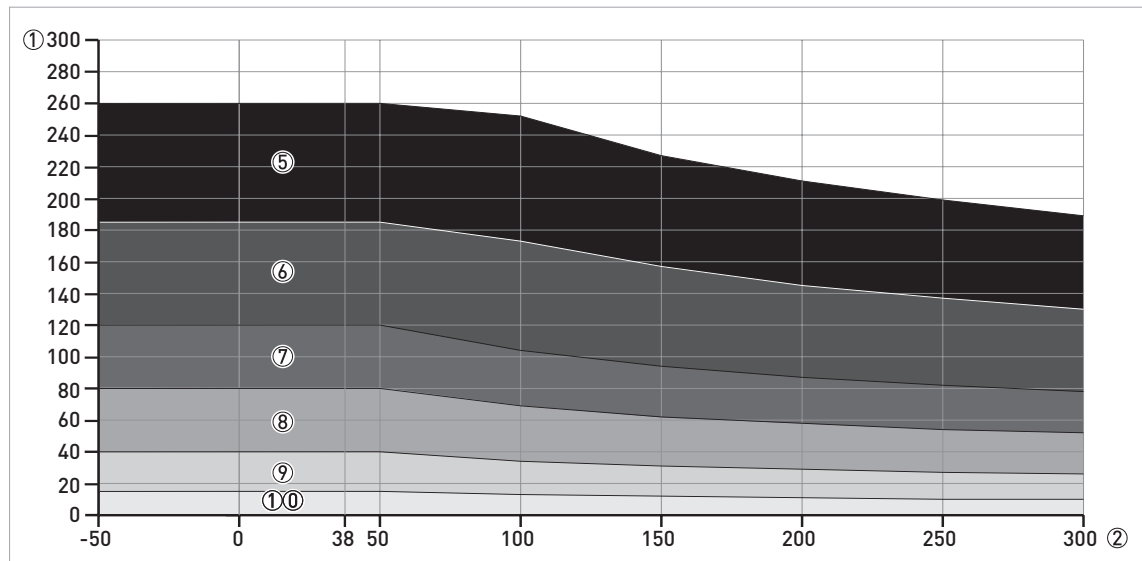

Figure 2-7: Pressure / temperature de-rating (ASME B16.5), Ø2 mm single cable probe (HT and HT/HP versions), in °C and barg

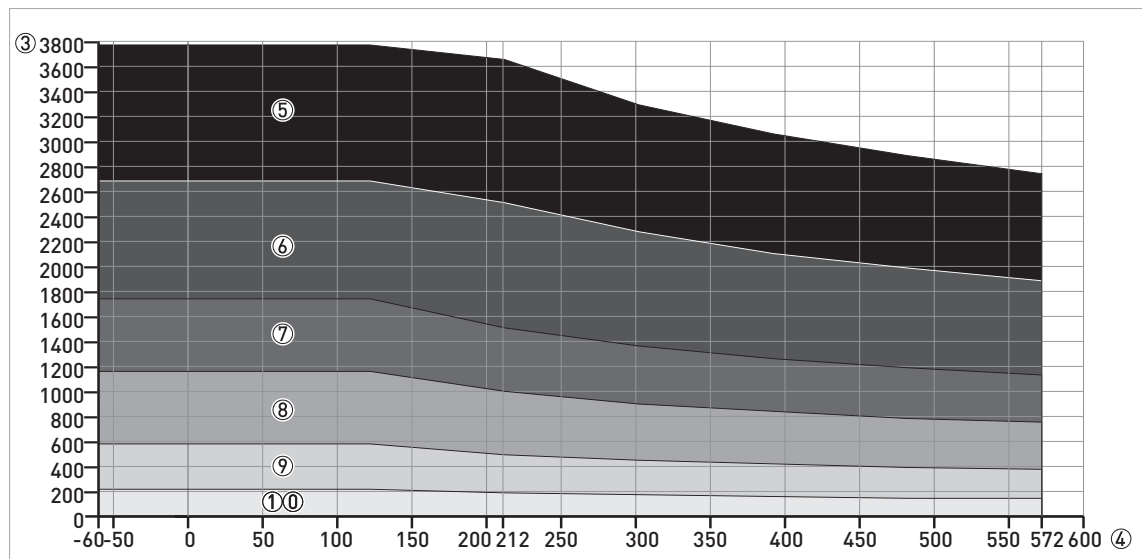

Figure 2-8: Pressure / temperature de-rating (ASME B16.5), Ø0.08" single cable probe (HT and HT/HP versions), in °F and psig

① p [barg]

② T [°C]

③ p [psig]

④ T [°F]

⑤ Flange connection, Class 2500: RJ flange facing only. Threaded connection, NPTF (ASME B1.20.3).

⑥ Flange connection, Class 1500: RJ flange facing only

⑦ Flange connection, Class 900: LT, LG, ST, SG and RJ flange facings only

⑧ Flange connection, Class 600

⑨ Flange connection, Class 300

⑩ Flange connection, Class 150

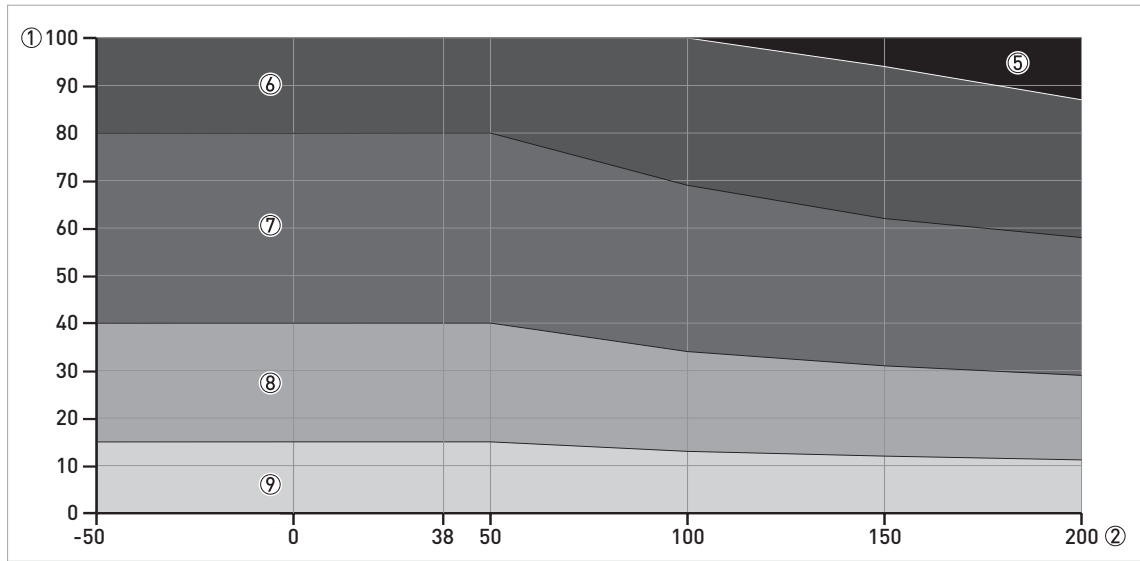

Figure 2-9: Pressure / temperature de-rating (ASME B16.5), all other probe types, in °C and barg

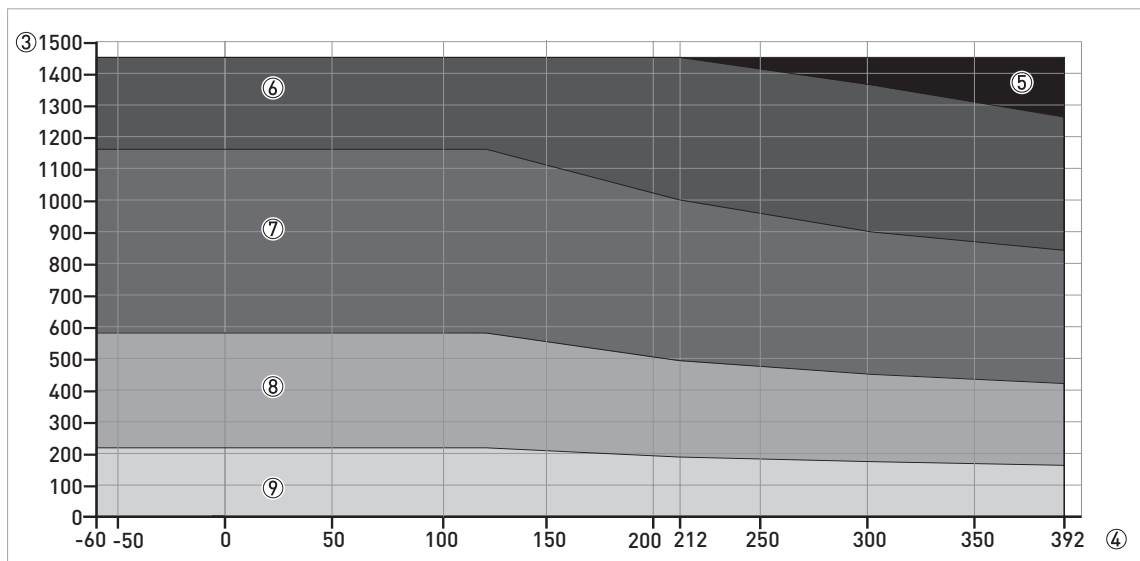

Figure 2-10: Pressure / temperature de-rating (ASME B16.5), all other probe types, in °F and psig

- ① p [barg]
- ② T [°C]
- ③ p [psig]
- ④ T [°F]
- ⑤ Flange connection, Class 1500: RJ flange facing only. Threaded connection, NPT (ASME B1.20.1).
- ⑥ Flange connection, Class 900: LT, LG, ST, SG and RJ flange facings only
- ⑦ Flange connection, Class 600
- ⑧ Flange connection, Class 300
- ⑨ Flange connection, Class 150

*The stress calculation agrees with ASME VIII Div. 1. The bolts used are made of SA193 B8M. Flange facings: LT = large tongue, LG = large groove, ST = small tongue, SG = small groove and RJ = ring joint.*

## 2.4 Measurement limits

### Double cable and double rod probes

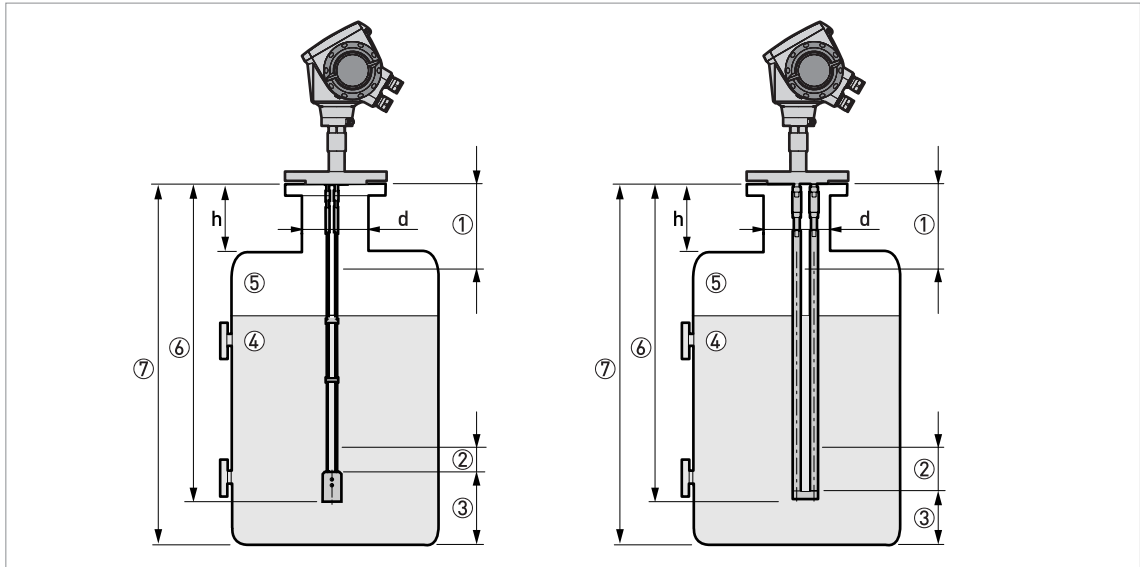

Figure 2-11: Measurement limits of the double cable probes (on the left side) and double rod probes (on the right side)

- ① **A1, Top dead zone:** Distance from the flange to the top limit of the measuring range. Refer to the notes and table that follow.
- ② **A2, Bottom dead zone:** Length at the end of the probe, where measurement is not linear.
- ③ **D, non measurement zone:** Zone where measurement cannot be taken.
- ④ **Product 1**
- ⑤ **Gas (Air)**
- ⑥ **L, Probe length:** Length specified by the customer in the order. This is also the maximum measuring length for some probe types in direct mode and all devices that operate in TBF mode.
- ⑦ **Tank Height**

*h* is the height of the nozzle. *d* is the diameter of the tank nozzle.

- If  $h < d$ , then the top dead zone (A1) is equal to the top dead zone for the probe only. Refer to the table that follows.
- If  $h \geq d$ , then the top dead zone (A1) is equal to the tank nozzle height plus the top dead zone for the probe.

### Measurement limits in mm and inches

Probes	Top dead zone, A1 $\epsilon_r = 80$		Bottom dead zone, A2 $\epsilon_r = 80$		Top dead zone, A1 $\epsilon_r = 2.3$		Bottom dead zone, A2 $\epsilon_r = 2.3$	
	[mm]	[inches]	[mm]	[inches]	[mm]	[inches]	[mm]	[inches]
Double rod Double cable	125	4.9	10	0.4	165	6.5	50	1.95

80 is  $\epsilon_r$  of water; 2.3 is  $\epsilon_r$  of oil

Single cable and single rod probes

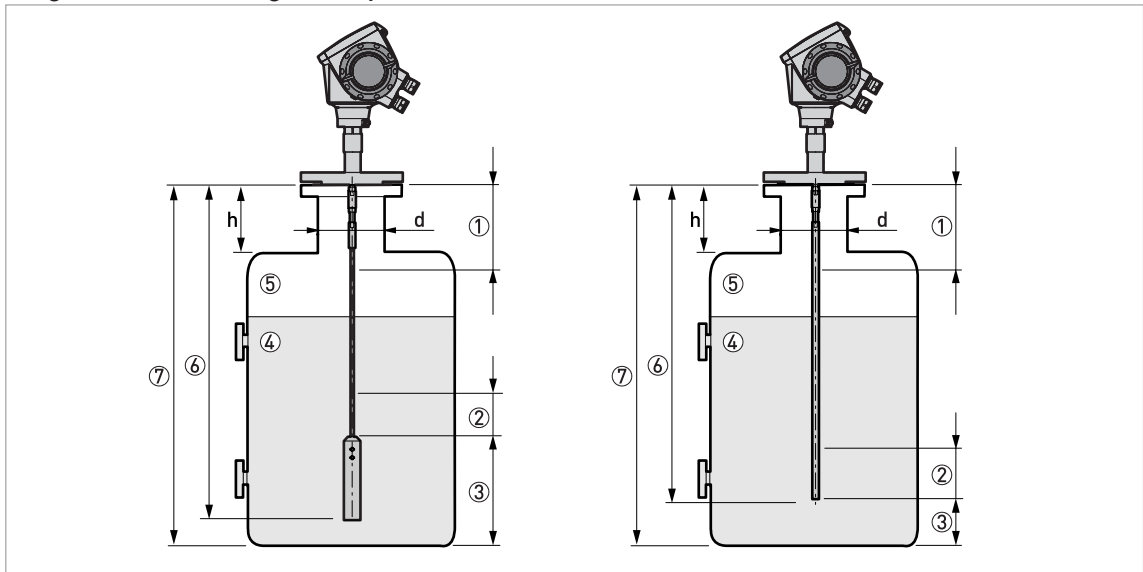

Figure 2-12: Measurement limits of the single cable probes (on the left side) and single rod probes (on the right side)

- ① **A1, Top dead zone:** Distance from the flange to the top limit of the measuring range. Refer to the notes and table that follow.
- ② **A2, Bottom dead zone:** Length at the end of the probe, where measurement is not linear.
- ③ **D, non measurement zone:** Zone where measurement cannot be taken.
- ④ **Product 1**
- ⑤ **Gas (Air)**
- ⑥ **L, Probe length:** Length specified by the customer in the order. This is also the maximum measuring length for some probe types in direct mode and all devices that operate in TBF mode.
- ⑦ **Tank Height**

*h* is the height of the nozzle. *d* is the diameter of the tank nozzle.

- If  $h < d$ , then the top dead zone (A1) is equal to the top dead zone for the probe only. Refer to the table that follows.
- If  $h \geq d$ , then the top dead zone (A1) is equal to the tank nozzle height plus the top dead zone for the probe.

Measurement limits in mm and inches

Probes	Top dead zone, A1 $\epsilon_r = 80$		Bottom dead zone, A2 $\epsilon_r = 80$		Top dead zone, A1 $\epsilon_r = 2.3$		Bottom dead zone, A2 $\epsilon_r = 2.3$	
	[mm]	[inches]	[mm]	[inches]	[mm]	[inches]	[mm]	[inches]
Single rod	200	7.9	10	0.4	250	9.9	50	1.95
Single cable								



## Coaxial probe

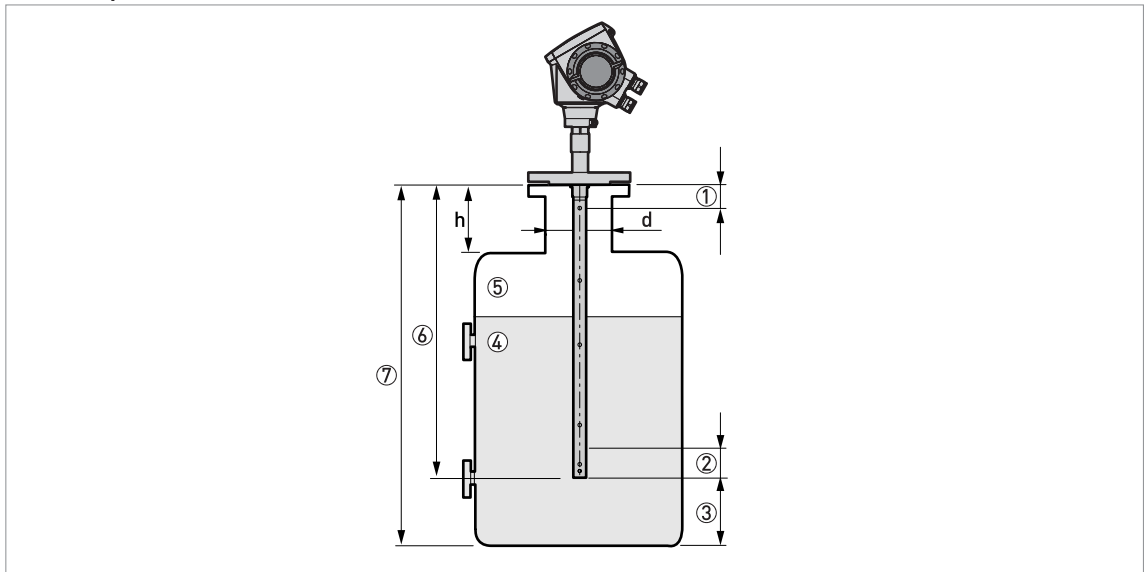

Figure 2-13: Measurement limits of the coaxial probe

- ① **A1, Top dead zone:** Distance from the flange to the top limit of the measuring range. Refer to the notes and table that follow.
- ② **A2, Bottom dead zone:** Length at the end of the probe, where measurement is not linear.
- ③ **D, non measurement zone:** Zone where measurement cannot be taken.
- ④ **Product 1**
- ⑤ **Gas (Air)**
- ⑥ **L, Probe length:** Length specified by the customer in the order. This is also the maximum measuring length for some probe types in direct mode and all devices that operate in TBF mode.
- ⑦ **Tank Height**

*h* is the height of the nozzle. *d* is the diameter of the tank nozzle.

*The dimensions of the tank nozzle have no effect on the top dead zone of the coaxial probe.*

## Measurement limits in mm and inches

Probes	Top dead zone, A1 $\epsilon_r = 80$		Bottom dead zone, A2 $\epsilon_r = 80$		Top dead zone, A1 $\epsilon_r = 2.3$		Bottom dead zone, A2 $\epsilon_r = 2.3$	
	[mm]	[inches]	[mm]	[inches]	[mm]	[inches]	[mm]	[inches]
Coaxial, flange connection	35	1.4	10	0.4	35	1.4	50	1.95
Coaxial, threaded connection	65	2.6	10	0.4	65	2.6	50	1.95

## 2.5 Dimensions and weights

## Converter and compact version

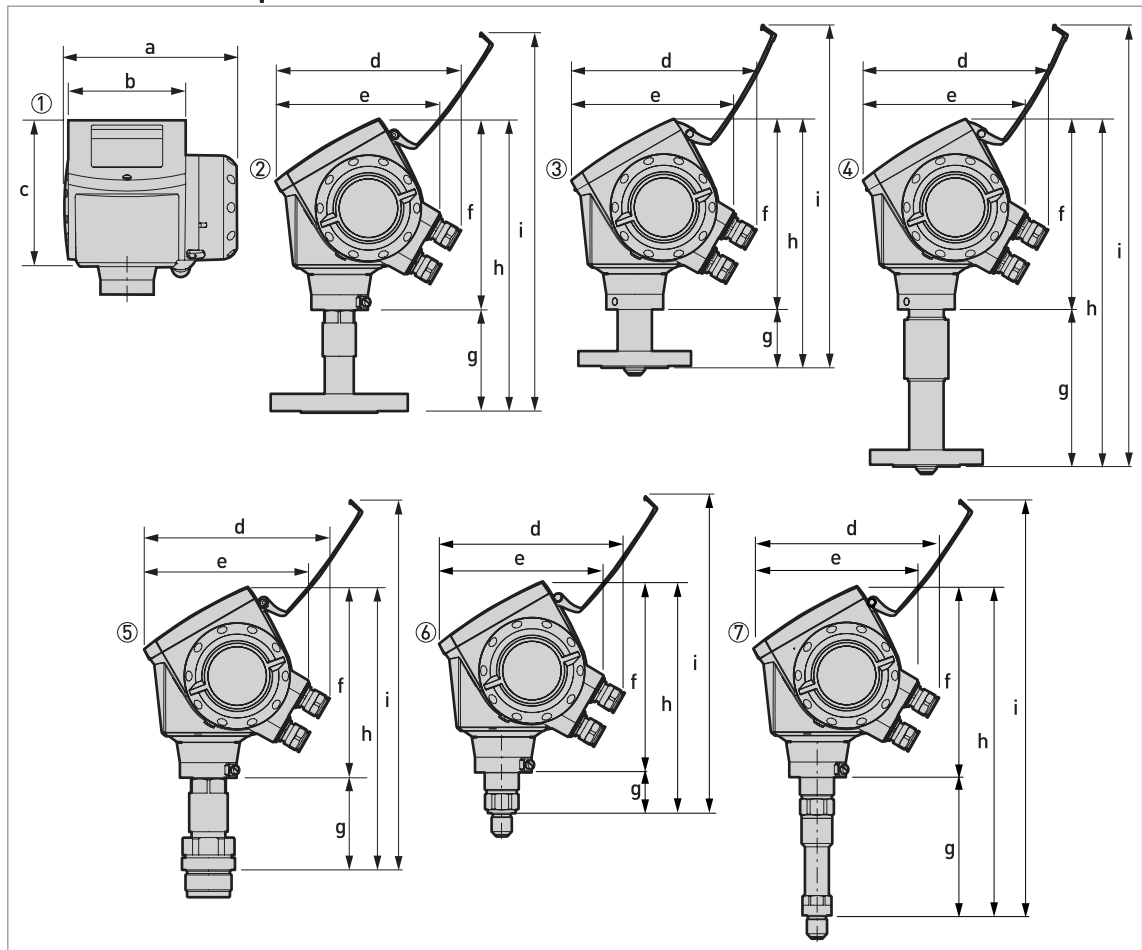

Figure 2-14: Converter and compact version

- ① Converter (front view)
- ② Flange version for all probes except the  $\varnothing 2$  mm / 0.08" single cable probe (right side)
- ③ Flange version for  $\varnothing 2$  mm / 0.08" single cable probe – High-Pressure (HP) version (right side)
- ④ Flange version for  $\varnothing 2$  mm / 0.08" single cable probe – High-Temperature (HT) and High-Temperature/High-Pressure (HT/HP) versions (right side)
- ⑤ Thread version for all probes except the  $\varnothing 2$  mm / 0.08" single cable probe (right side)
- ⑥ Thread version for  $\varnothing 2$  mm / 0.08" single cable probe – High-Pressure (HP) version (right side)
- ⑦ Thread version for  $\varnothing 2$  mm / 0.08" single cable probe – High-Temperature (HT) and High-Temperature/High-Pressure (HT/HP) versions (right side)

- Cable glands are delivered on demand with non-Ex, Ex i- and Ex d-approved devices.
- Non-Ex and Ex i fittings are plastic and Ex d fittings are metallic. Non-Ex fittings are black and Ex i fittings are blue.
- The diameter of the outer sheath of the cable must be 7...12 mm or 0.28...0.47".
- Cable glands for FM- or CSA-approved devices must be supplied by the customer.

## Dimensions and weights in mm and kg

	Dimensions [mm]									Weights [kg]
	a	b	c	d	e	f	g	h	i	
Converter	180	122	158.5	182 ①	170	197	—	—	—	3.3
Flange, single cable Ø2 – version HT or HT/HP	180	122	158.5	182 ①	170	197	160	357 ②	450 ②	6...15
Flange, single cable Ø2 – version HP	180	122	158.5	182 ①	170	197	59	256 ②	349 ②	5...14
Flange, all other probes	180	122	158.5	182 ①	170	197	123	320 ②	357 ②	4...12
Thread, single cable Ø2 – version HT or HT/HP	180	180	158.5	182 ①	170	197	144	341 ②	37 8 ②	4.5
Thread, single cable Ø2 – version HP	180	180	158.5	182 ①	170	197	43	240 ②	277 ②	4
Thread, all other probes	180	122	158.5	182 ①	170	197	95	292 ②	329 ②	3

① This dimension is subject to the size of the cable gland used

② With 30 kV ESD protection option: add 99 mm to this dimension. With Metaglas® option: add 43 mm to this dimension.

## Dimensions and weights in inches and lb

	Dimensions [inches]									Weights [lb]
	a	b	c	d	e	f	g	h	i	
Converter	7.1	4.8	6.2	7.2 ①	6.7	7.8	—	—	—	7.3
Flange, single cable Ø0.08 – version HT or HT/HP	7.1	4.8	6.2	7.2 ①	6.7	7.8	6.2	14 ②	17.7 ②	13.2...33.1
Flange, single cable Ø0.08 – version HP	7.1	4.8	6.2	7.2 ①	6.7	7.8	2.3	10.1 ②	13.7 ②	11...30.9
Flange, all other probes	7.1	4.8	6.2	7.2 ①	6.7	7.8	4.8	12.6 ②	14.1 ②	8.8...26.5
Thread, single cable Ø0.08 – version HT or HT/HP	7.1	4.8	6.2	7.2 ①	6.7	7.8	5.6	13.4 ②	14.9 ②	9.9
Thread, single cable Ø0.08 – version HP	7.1	4.8	6.2	7.2 ①	6.7	7.8	1.6	9.4 ②	10.9 ②	8.8
Thread, all other probes	7.1	4.8	6.2	7.2 ①	6.7	7.8	3.7	11.5 ②	12.9 ②	6.6

① This dimension is subject to the size of the cable gland used

② With 30 kV ESD protection option: add 3.9" to this dimension. With Metaglas® option: add 1.7" to this dimension.

## Remote version

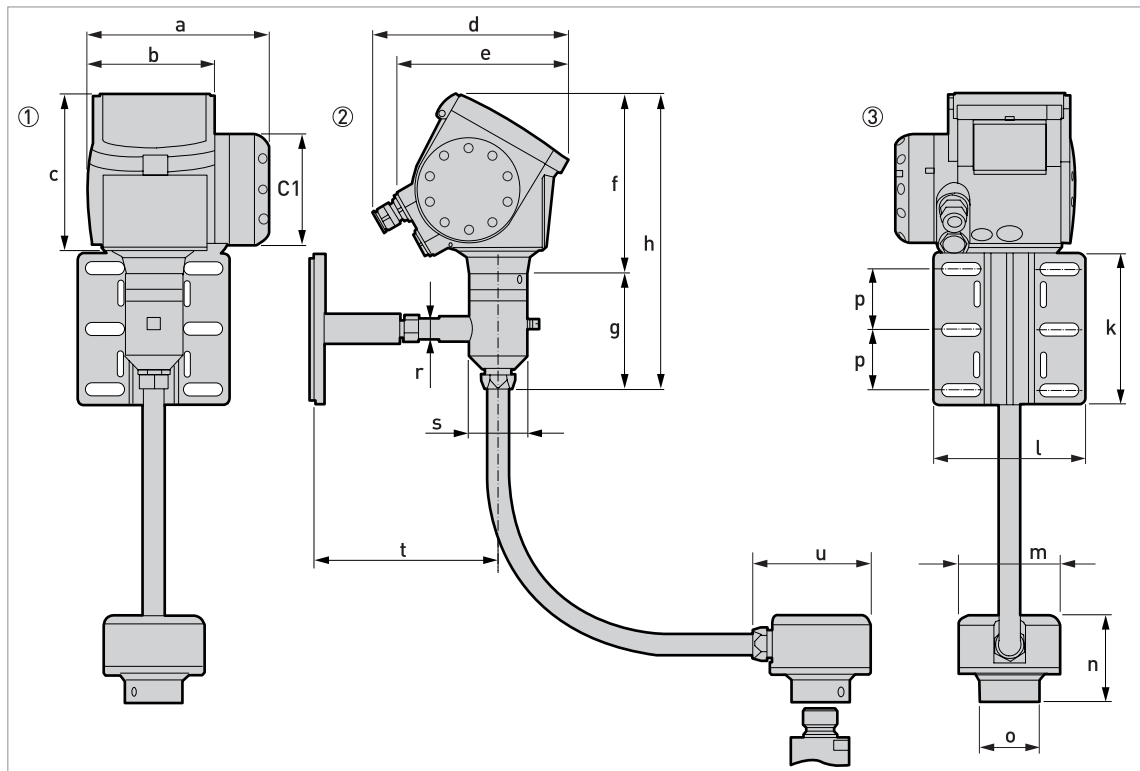

Figure 2-15: Remote version

- ① Front view
- ② Left side
- ③ Rear view

- A wall bracket is supplied with the remote version. You can attach the wall bracket to a wall or pipe (DN50...100 / 2" ...4"). For the assembly procedure, refer to the handbook.
- For more data about the dimensions of the remote converter (dimensions "a", "b", "c", "d" and "e"), refer to the illustration and tables for "Converter and compact version".

### Dimensions and weights in mm and kg

	Dimensions [mm]														Weights [kg]
	C1	f	g	h	k	l	m	n	o	p	r	s	t	u	
Remote version	165	197	98.5	295.5	150	150.4	100	86 <sup>①</sup>	58	60	21	58	183	117	6.6... 12.8 <sup>②</sup>

① With 30 kV ESD protection option: add 99 mm to this dimension. With Metaglas® option: add 43 mm to this dimension.

② Wall bracket (1.4 kg) + converter support (1.5 kg) + remote probe converter (2.7 kg) + flexible conduit (2 m: 1 kg; 4.5 m: 2.25 kg; 9.5 m: 4.75 kg; 14.5 m: 7.25 kg)

### Dimensions and weights in inches and lb

	Dimensions [inches]														Weights [lb]
	C1	f	g	h	k	l	m	n	o	p	r	s	t	u	
Remote version	6.50	7.76	3.88	11.64	5.91	5.92	3.94	3.39 <sup>①</sup>	2.28	2.36	0.83	2.28	7.20	4.60	14.6... 28.3 <sup>②</sup>

① With 30 kV ESD protection option: add 3.9" to this dimension. With Metaglas® option: add 1.7" to this dimension.

② Wall bracket (3.1 lb) + converter support (3.3 lb) + remote probe converter (6.0 lb) + flexible conduit (6.6 ft: 2.2 lb; 14.8 ft: 5.0 lb; 31.2 ft: 10.5 lb; 47.6 ft: 16.0 lb)

#### Remote version limits

- For interface and solid (powder, granulate) applications, the maximum extension length is 4.5 m / 14.8 ft.
- For liquid level applications, the maximum measuring range is reduced according to the length of the coaxial cable between the flange and the converter (extension length).

Extension length		Max. measuring range (or sensor length, L)	
[m]	[ft]	[m]	[ft]
2	6.6	30	98
4.5	14.8	25	82
9.5	31.2	15	29
14.5	47.6	5	16.4

#### Applications for the remote version

- Tanks which are subjected to a lot of vibration
- Limited space on the top of the tank or limited access (due to the size of the compact converter)
- Remote display at the bottom of the tank

Weather protection option

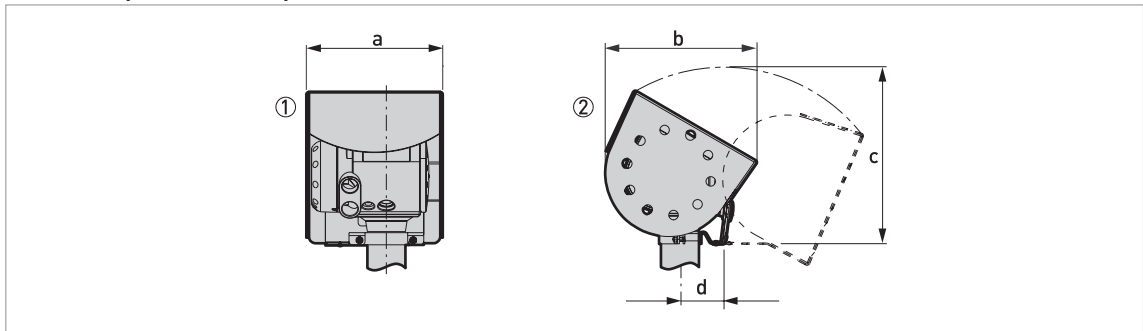

Figure 2-16: Weather protection option

- ① Weather protection (rear view)
- ② Weather protection (left side)

Dimensions and weights in mm and kg

	Dimensions [mm]				Weights [kg]
	a	b	c	d	
Weather protection	208	231.5	268 ①	66	2.9

① Radius

Dimensions and weights in inches and lb

	Dimensions [inches]				Weights [lb]
	a	b	c	d	
Weather protection	8.2	9.1	10.6 ①	2.6	6.4

① Radius

## ESD protection and Metaglas® options

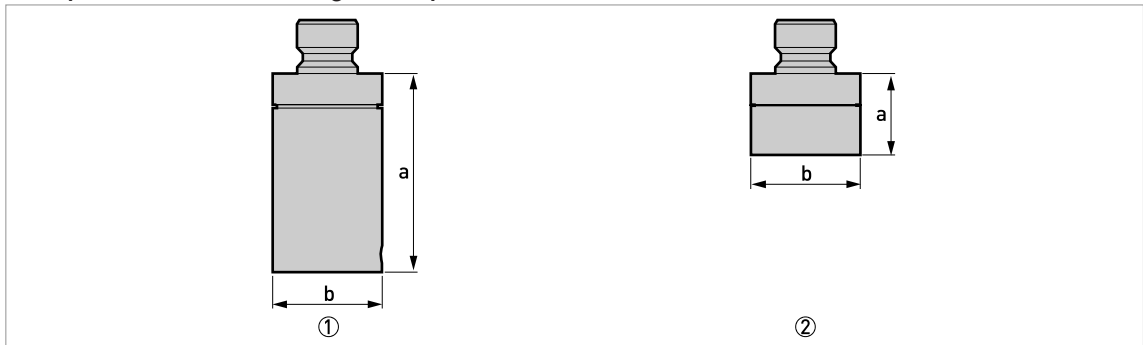

Figure 2-17: ESD protection and secondary Metaglas® seal options

- ① Optional ESD protection (30 kV) for solid applications
- ② Optional Metaglas® (dual process sealing system for dangerous products)

*The ESD protection and the Metaglas® options cannot be fitted to the same device.*

## Special options: Dimensions and weights in mm and kg

Options	Dimensions [mm]		Weights [kg]
	a	b	
ESD protection 30 kV	99	Ø58	0.85
Metaglas®	43	Ø58	0.83

## Special options: Dimensions and weights in inches and lb

Options	Dimensions [inches]		Weights [lb]
	a	b	
ESD protection 30 kV	3.9	Ø2.3	1.87
Metaglas®	1.7	Ø2.3	1.82

## Single probes

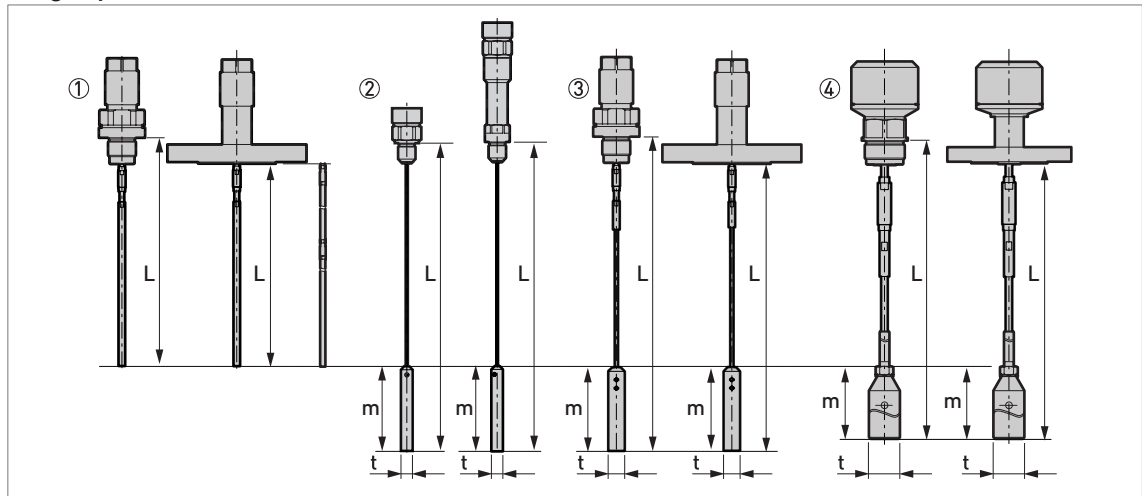

Figure 2-18: Single probe options

- ① Single rod  $\varnothing 8$  mm /  $\varnothing 0.32$ " (thread and flange versions). A segmented probe option is shown on the right side. An optional protective sheath is available on request for the flange version.
- ② Single cable  $\varnothing 2$  mm /  $\varnothing 0.08$ " (the only thread version for the High-Pressure (HP) option and the only thread version for the High-Temperature (HT) and High-Temperature/High-Pressure (HT/HP) options)
- ③ Single cable  $\varnothing 4$  mm /  $\varnothing 0.16$ " (thread and flange versions – an optional FEP coating is available on request)
- ④ Single cable  $\varnothing 8$  mm /  $\varnothing 0.32$ " (thread and flange versions)

*A wide range of counterweights and anchoring solutions are available. For dimensional data, refer to the pages that follow. For installation data, refer to the handbook.*



## Single probes: Dimensions in mm

Probes	Dimensions [mm]			
	L min.	L max.	m	t
Single rod Ø8 mm ①	600 ②	4000	–	–
Single rod Ø8 mm (segmented) ①	600 ②	6000	–	–
Single cable Ø2 mm ③	600 ②	35000	100	Ø14
Single cable Ø4 mm ④	600 ②	35000	100	Ø20
Single cable Ø8 mm ④	600 ②	35000	245 ⑤	Ø38

① A device with this probe option must be assembled on site. For the assembly procedure, refer to the handbook or the printed procedure supplied with the components.

② A shorter probe length is available on request

③ 1 counterweight option (Ø14×100 mm). No anchoring solution is available.

④ Refer to the end of this section for data about all the probe end options

⑤ This value is for the Ø38 mm counterweight. If you ordered the Ø12 mm counterweight: 100 mm

## Single probes: Dimensions in inches

Probes	Dimensions [inches]			
	L min.	L max.	m	t
Single rod Ø0.32" ①	24 ②	158	–	–
Single rod Ø0.32" (segmented) ①	24 ②	236	–	–
Single cable Ø0.08" ③	24 ②	1378	3.9	Ø0.6
Single cable Ø0.16" ④	24 ②	1378	3.9	Ø0.8
Single cable Ø0.32" ④	24 ②	1378	9.6 ⑤	Ø1.5

① A device with this probe option must be assembled on site. For the assembly procedure, refer to the handbook or the printed procedure supplied with the components.

② A shorter probe length is available on request

③ 1 counterweight option (Ø0.6×3.9"). No anchoring solution is available.

④ Refer to the end of this section for data about all the probe end options

⑤ This value is for the Ø1.5" counterweight. If you ordered the Ø0.5" counterweight: 3.9"

## Double probes

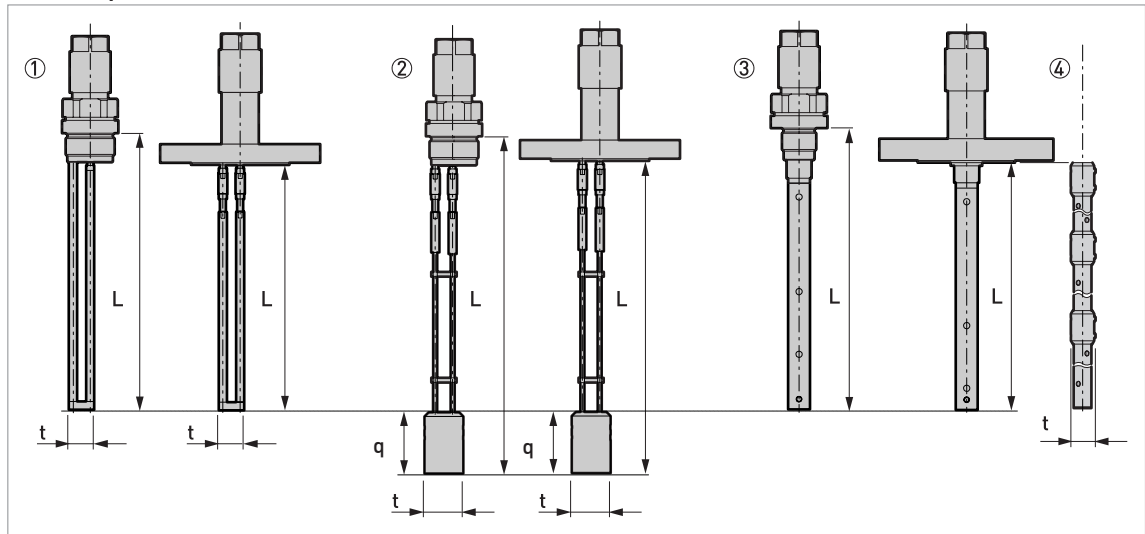

Figure 2-19: Double probe options

- ① Double rod  $\varnothing 8$  mm /  $\varnothing 0.32$ " (thread and flange versions)
- ② Double cable  $\varnothing 4$  mm /  $\varnothing 0.16$ " (thread and flange versions)
- ③ Coaxial  $\varnothing 22$  mm /  $\varnothing 0.87$ " (thread and flange versions)

*A wide range of counterweights and anchoring solutions are available. For dimensional data, refer to the pages that follow. For installation data, refer to the handbook.*

**Double probes: Dimensions in mm**

Probes	Dimensions [mm]			
	L min.	L max.	q	t
Double rod Ø8 mm	600 ①	4000	–	25
Double cable Ø4 mm ②	600 ①	8000	60	Ø38
Coaxial Ø22 mm	300 ①	6000	–	–
Coaxial Ø22 mm (segmented) ③	300 ①	6000	–	Ø28

① A shorter probe length is available on request

② Refer to the end of this section for data about all the probe end options

③ A device with this probe option must be assembled on site. For the assembly procedure, refer to the handbook or the printed procedure supplied with the components.

**Double probes: Dimensions in inches**

Probes	Dimensions [inches]			
	L min.	L max.	q	t
Double rod Ø0.32"	24 ①	158	–	1.0
Double cable Ø0.16" ②	24 ①	315	2.4	Ø1.5
Coaxial Ø0.87"	12 ①	236	–	–
Coaxial Ø0.87" (segmented) ③	12 ①	236	–	Ø1.1

① A shorter probe length is available on request

② Refer to the end of this section for data about all the probe end options

③ A device with this probe option must be assembled on site. For the assembly procedure, refer to the handbook or the printed procedure supplied with the components.

Probe end options for cable probes: single cable Ø4 mm / 0.16"

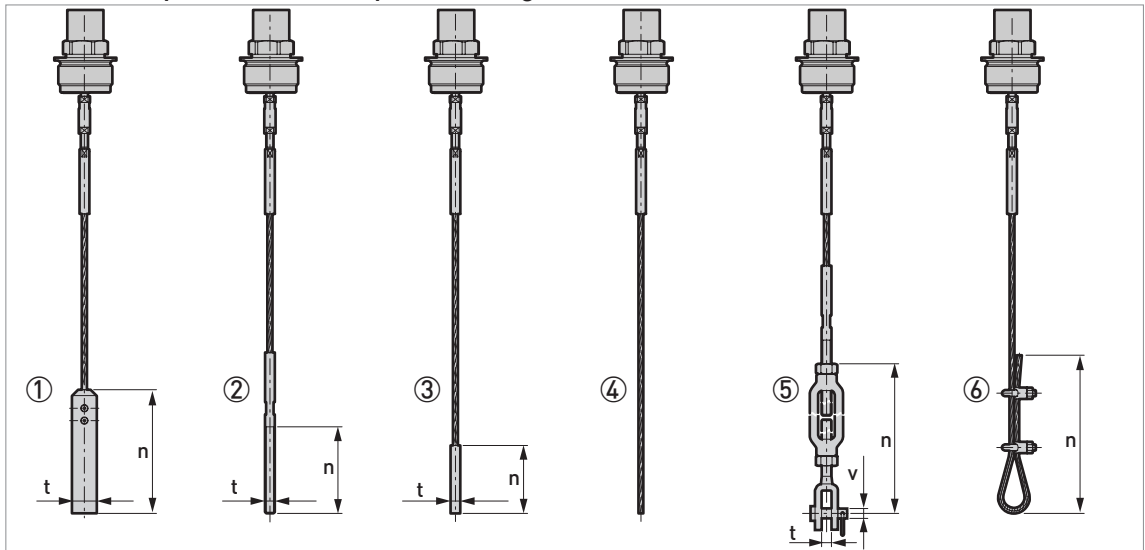

Figure 2-20: Probe end options for cable probes: single cable Ø4 mm / 0.16"

- ① Standard counterweight
- ② Threaded end
- ③ Crimped end
- ④ Open end
- ⑤ Turnbuckle
- ⑥ Chuck

Dimensions in mm

Probe end type	Dimensions [mm]		
	n	t	v
Counterweight	100	Ø20	—
Threaded end	70	M8	—
Crimped end	55	Ø8	—
Open end	—	—	—
Turnbuckle	172 ①	11	Ø6
Chuck	300	—	—

① Minimum length

Dimensions in inches

Probe end type	Dimensions [inches]		
	n	t	v
Counterweight	3.9	Ø0.8	—
Threaded end	2.8	M8	—
Crimped end	2.2	Ø0.3	—
Open end	—	—	—
Turnbuckle	6.8 ①	0.4	Ø0.2
Chuck	11.8	—	—

① Minimum length

Probe end options for cable probes: single cable Ø8 mm / 0.32"

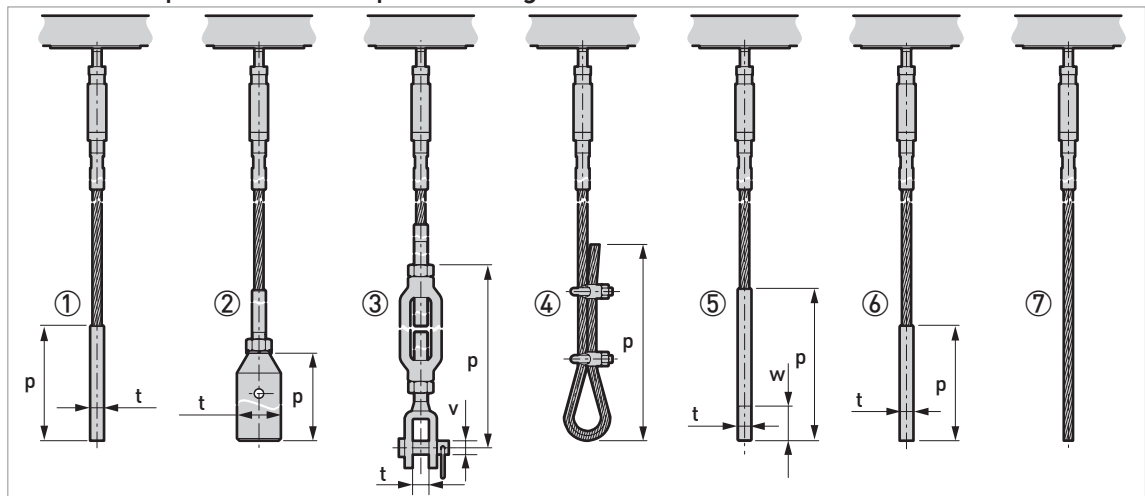

Figure 2-21: Probe end options for cable probes: single cable Ø8 mm / 0.32"

- ① Standard counterweight 1
- ② Standard counterweight 2
- ③ Turnbuckle
- ④ Chuck
- ⑤ Threaded end
- ⑥ Crimped end
- ⑦ Open end

### Dimensions in mm

Probe end type	Dimensions [mm]			
	p	t	v	w
Counterweight 1	100	Ø12	—	—
Counterweight 2	245	Ø38	—	—
Turnbuckle	293 ①	14	Ø12	—
Chuck	300	—	—	—
Threaded end	132	M12	—	30
Crimped end	100	Ø12	—	—
Open end	—	—	—	—

① Minimum length

### Dimensions in inches

Probe end type	Dimensions [inches]			
	p	t	v	w
Counterweight 1	3.9	Ø0.5	—	—
Counterweight 2	9.6	Ø1.5	—	—
Turnbuckle	11.5 ①	0.6	Ø0.5	—
Chuck	11.8	—	—	—
Threaded end	5.2	M12	—	1.2
Crimped end	3.9	Ø0.5	—	—
Open end	—	—	—	—

① Minimum length

Probe end options for cable probes: double cable Ø4 mm / 0.16"

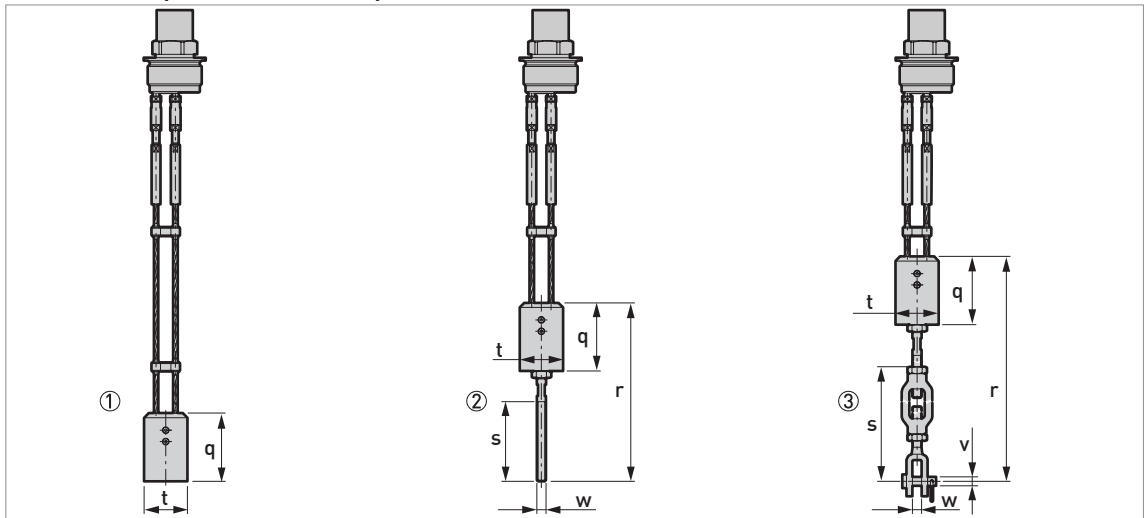

Figure 2-22: Probe end options for cable probes: double cable Ø4 mm / 0.16"

- ① Standard counterweight
- ② Threaded end
- ③ Turnbuckle

Dimensions in mm

Probe end type	Dimensions [mm]					
	q	r	s	t	v	w
Counterweight	60	—	—	Ø38	—	—
Threaded end	60	157	70	Ø38	—	M8
Turnbuckle	60	289 ±46	172 ①	Ø38	Ø6	11

① Minimum length

Dimensions in inches

Probe end type	Dimensions [inches]					
	q	r	s	t	v	w
Counterweight	2.4	—	—	Ø1.5	—	—
Threaded end	2.4	6.2	2.8	Ø1.5	—	M8
Turnbuckle	2.4	11.4 ±1.8	6.8 ①	Ø1.5	Ø0.2	0.4

① Minimum length

## Probe weights

Probes	Min. process connection size		Weights	
	Thread	Flange	[kg/m]	[lb/ft]
Single cable Ø2 mm / 0.08"	G ½A; ½ NPTF	DN25 in PN16, PN40, PN63 or PN100; 1" in 150 lb, 600 lb, 900 lb, 1500 lb or 2500 lb; 1½" in 300 lb	0.016	0.01
Single cable Ø4 mm / 0.16"	G ¾A; ¾ NPT	DN25 in PN16, PN40, PN63 or PN100; 1" in 150 lb, 600 lb, 900 lb or 1500 lb; 1½" in 300 lb	0.12	0.08
Single cable Ø8 mm / 0.32"	G 1½A; 1½ NPT	DN40 in PN16, PN40, PN63 or PN100; 1½" in 150 lb, 300 lb, 600 lb, 900 lb or 1500 lb	0.41	0.28
Double cable Ø4 mm / 0.16"	G 1½A; 1½ NPT	DN50 in PN16, PN40, PN63 or PN100; 2" in 150 lb, 300 lb, 600 lb, 900 lb or 1500 lb	0.24	0.16
Single rod Ø8 mm / 0.32"	G ¾A; ¾ NPT	DN25 in PN16, PN40, PN63 or PN100; 1" in 150 lb, 600 lb, 900 lb or 1500 lb; 1½" in 300 lb	0.41	0.28
Double rod Ø8 mm / 0.32"	G 1½A; 1½ NPT	DN50 in PN16, PN40, PN63 or PN100; 2" in 150 lb, 300 lb, 600 lb, 900 lb or 1500 lb	0.82	0.56
Coaxial Ø22 mm / 0.87"	G ¾A; ¾ NPT	DN25 in PN16, PN40, PN63 or PN100; 1" in 150 lb, 600 lb, 900 lb or 1500 lb; 1½" in 300 lb	0.79	0.53

### 3.1 Intended use

*Responsibility for the use of the measuring devices with regard to suitability, intended use and corrosion resistance of the used materials against the measured fluid lies solely with the operator.*

*The manufacturer is not liable for any damage resulting from improper use or use for other than the intended purpose.*

This TDR level transmitter measures distance, level, mass and volume of liquids, pastes, slurries, granulates and powders. It can also measure level and interface of liquids at the same time.

It can be installed on tanks, silos and open pits.

### 3.2 Pre-installation requirements

*Obey the precautions that follow to make sure that the device is correctly installed.*

- Make sure that there is sufficient space on all sides.
- Protect the signal converter from direct sunlight. If necessary, install the weather protection accessory.
- Do not subject the signal converter to heavy vibrations. The devices are tested for vibration and agree with EN 50178 and IEC 60068-2-6.



### 3.3 How to prepare the tank before you install the device

To avoid measuring errors and device malfunction, obey these precautions.

#### 3.3.1 General information for nozzles

Follow these recommendations to make sure that the device measures correctly.

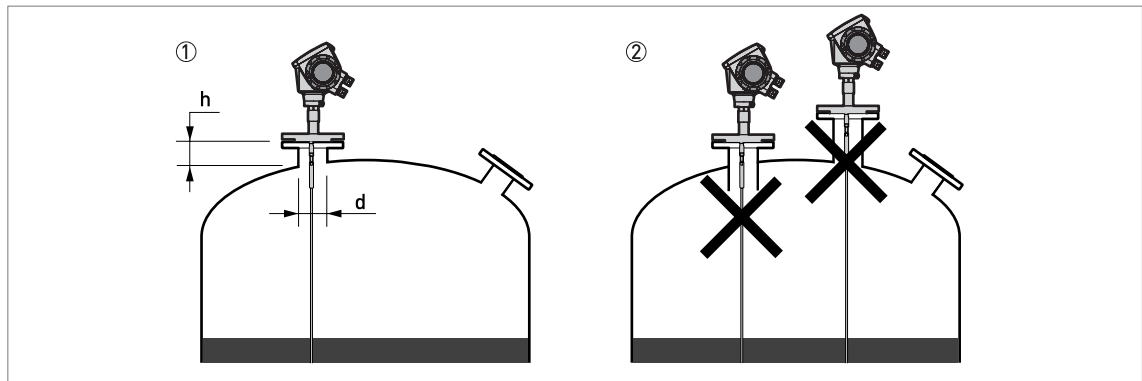

Figure 3-1: Recommended nozzle dimensions for single rod and single cable probes

- ① Recommended conditions:  $h \leq d$ , where  $h$  is the height of the tank nozzle and  $d$  is the diameter of the tank nozzle.
- ② The end of the nozzle must not have an extension into the tank. Do not install the device on a high nozzle.

If the device is installed on a high nozzle, make sure that the probe does not touch the side of the nozzle (attach the probe end, ...). We recommend that you use a coaxial probe (this solution is applicable only to liquids).

It is possible to measure in these conditions with a minimum top dead zone. Use the snapshot function to filter the parasite signals from long nozzles. For more data, refer to the Handbook.

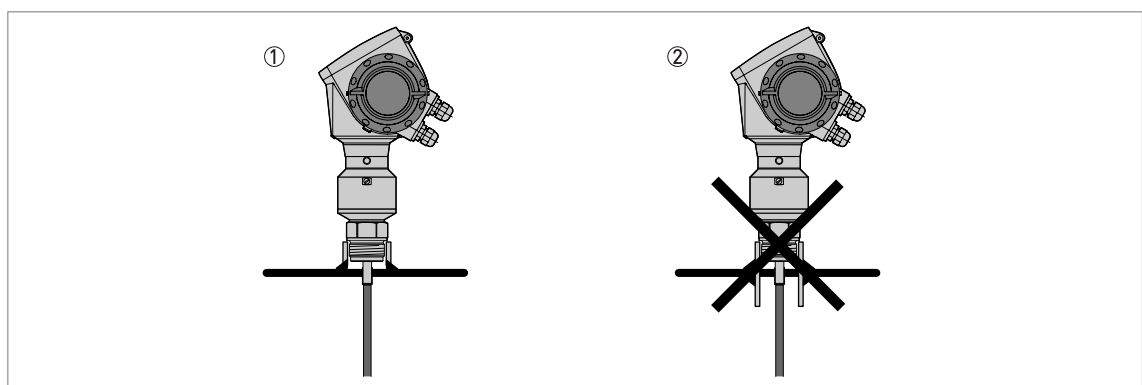
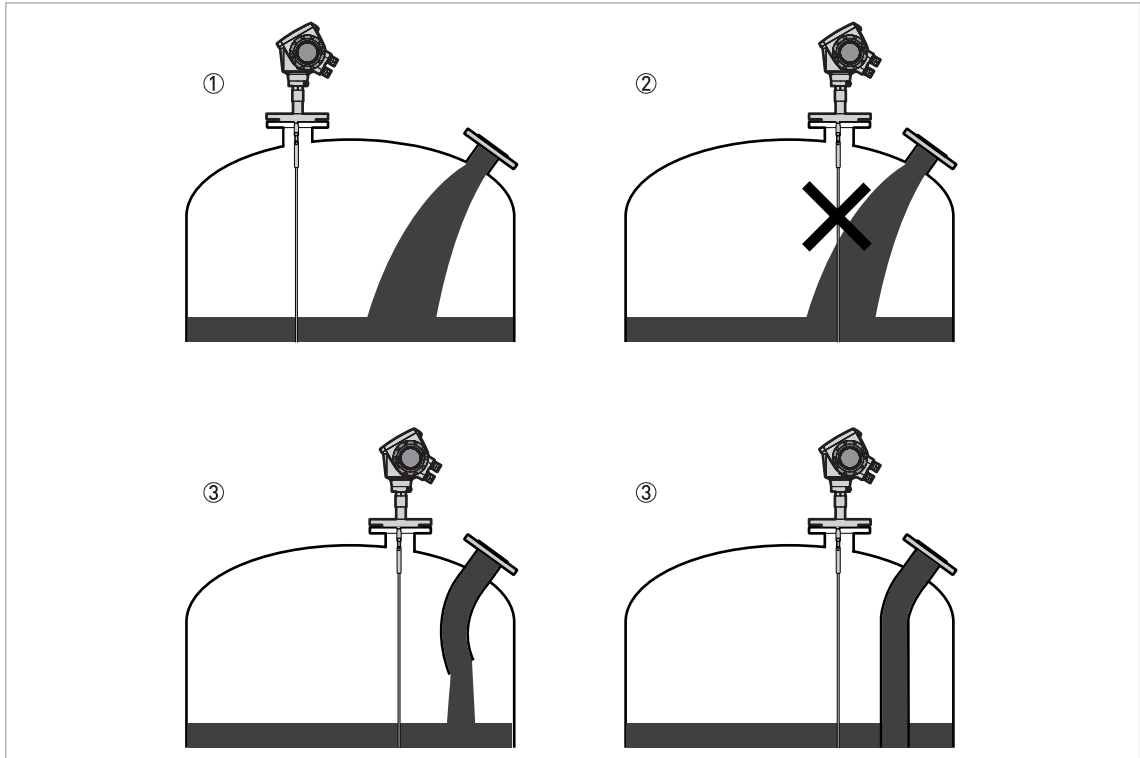

Figure 3-2: Sockets for threaded process connections

- ① Recommended installation
- ② The end of the socket must not have an extension into the tank

*Do not put the process connection near to the product inlet. If the product that enters the tank touches the probe, the device will measure incorrectly.*



**Figure 3-3: Do not put the device near to a product inlet**

- ① The device is in the correct position.
- ② The device is too near to the product inlet.
- ③ If it is not possible to put the device in the recommended position, install a deflector pipe.

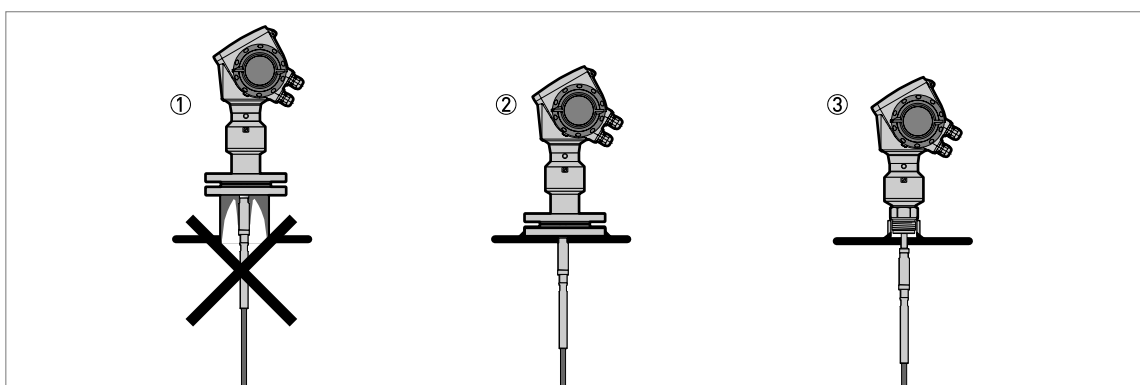

**Figure 3-4: How to prevent build-up of product around the process connection**

- ① If product particles are likely to collect in holes, a nozzle is not recommended.
- ② Attach the flange directly to the tank.
- ③ Use a threaded connection to attach the device directly to the tank.

*If your device has a coaxial probe, you can ignore these installation recommendations.*

*Install coaxial probes in clean liquids that are not too viscous.*

### 3.3.2 Installation requirements for concrete roofs

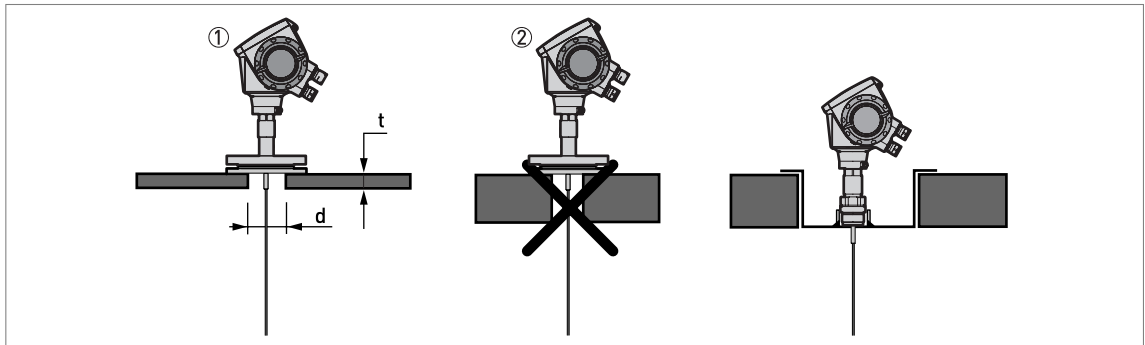

Figure 3-5: Installation on a concrete roof

- ① The diameter,  $d$ , of the hole must be greater than the thickness,  $t$ , of the concrete.
- ② If the thickness,  $t$ , of the concrete is greater than the diameter,  $d$ , of the hole, install the device in a recess.

### 3.3.3 Recommendations for pits and tanks made of non-conductive materials

**If you have a device with a single rod or a single cable probe and a thread connection, obey these instructions:**

- Put a metal sheet between the device and the process connection.
- It must have a diameter greater than 200 mm / 8".
- Make sure that the metal sheet is in contact with the thread stop on the device.

We recommend that you use  $DN \geq 200$  /  $\geq 8''$  for flange connections.

If you have a device with a double rod, double cable or coaxial probe, you can ignore these instructions.

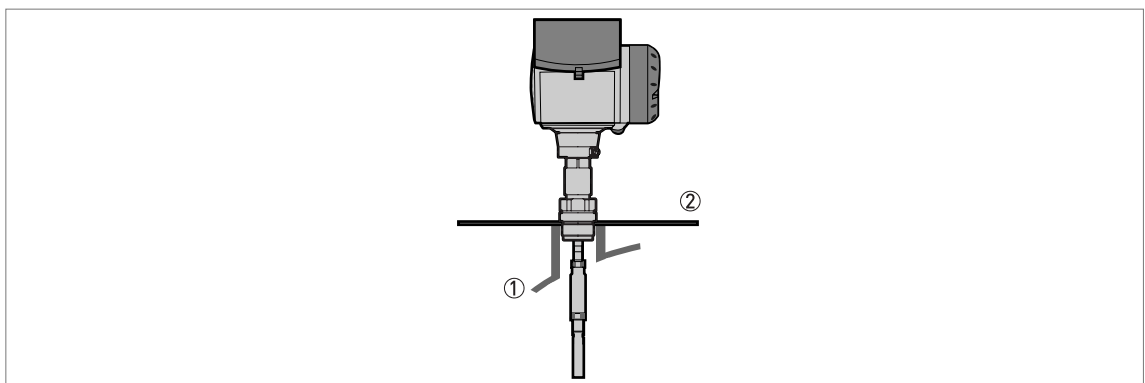

Figure 3-6: Installation in a non-metallic tank or pit with a thread connection

- ① Non-metallic (plastic...) tank or pit
- ② Metal sheet,  $\varnothing \geq 200$  mm / 8"

*When the device is installed, make sure that the tank roof has no deformation.*

### 3.4 Installation recommendations for liquids

#### 3.4.1 General requirements

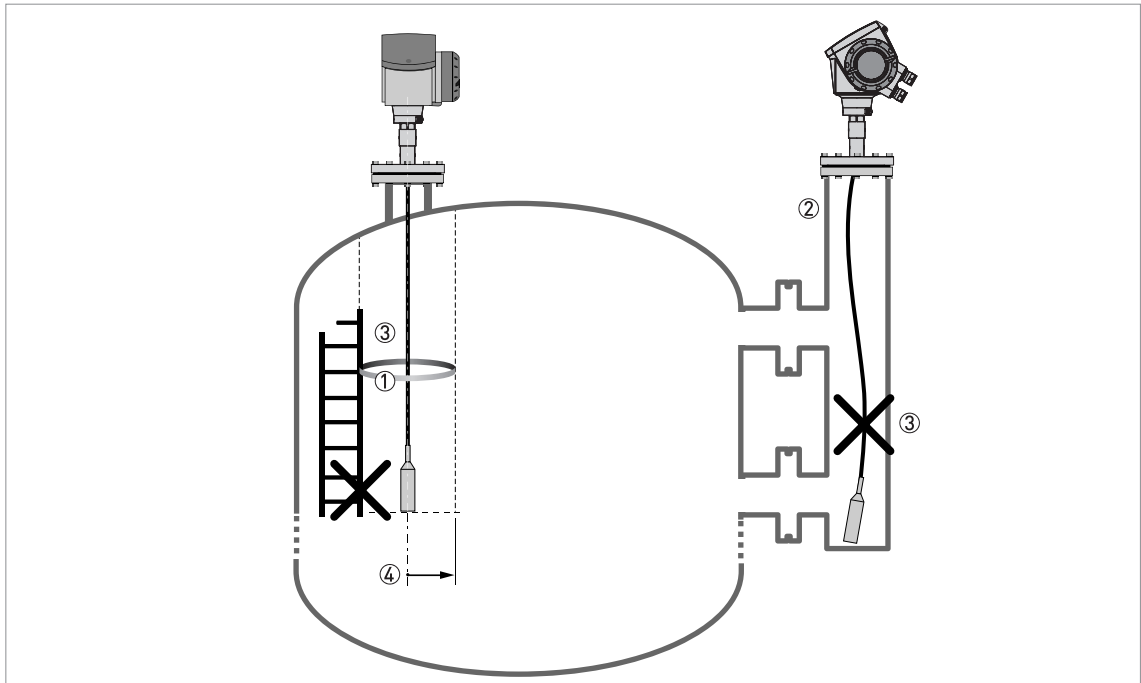

Figure 3-7: Installation recommendations for liquids

- ① The electromagnetic (EM) field generated by the device. It has a radius of  $R_{min}$ . Make sure that the EM field is clear of objects and product flow. Refer to the table that follows.
- ② If there are too many objects in the tank, install a bypass chamber or stilling well.
- ③ Keep the probe straight. If the probe is too long, shorten the probe length. Make sure that the device is configured with the new probe length. For more data on the procedure, refer to the handbook.
- ④ Empty space. Refer to the table that follows.

*If the device has to measure the level of dangerous products (ammonia etc.), we recommend that you use a device with the Metaglas® option.*

#### Clearance between the probe and other objects in the tank

Probe type	Empty space (radius, $R_{min}$ ), around the probe	
	[mm]	[inches]
Coaxial	0	0
Double rod / cable	100	4
Single rod / cable	300	12

### 3.4.2 Standpipes

Use a standpipe if:

- There is highly conductive foam in the tank.
- The liquid is very turbulent or agitated.
- There are too many other objects in the tank.
- The device is measuring a liquid (petro-chemicals) in a tank with a floating roof.

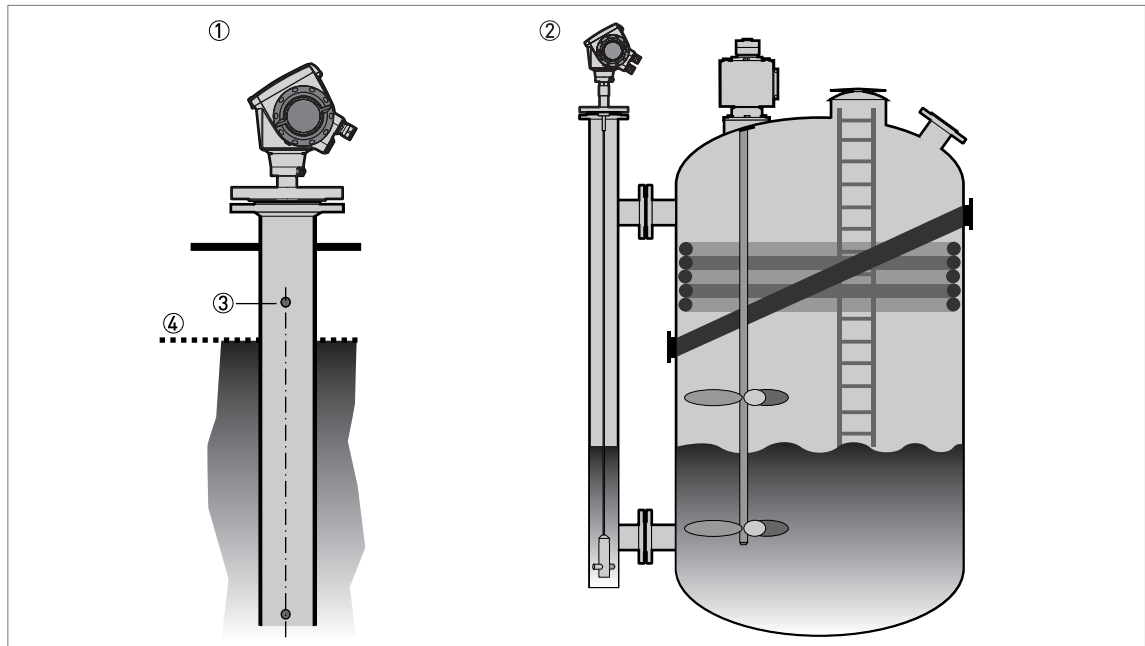

Figure 3-8: Basic installation recommendations for standpipes (stilling wells and bypass chambers)

- ① Stilling well
- ② Bypass chamber
- ③ Air circulation hole
- ④ Level of the liquid

#### **Installation requirements**

- *The standpipe must be electrically conductive.*
- *The standpipe must be straight. There must be no sudden changes in internal diameter greater than 1 mm / 0.04".*
- *The standpipe must be vertical.*
- *Recommended surface roughness:  $\leq \pm 0.1 \text{ mm} / 0.004"$ .*
- *Stilling well only: The bottom of the stilling well must be open.*
- *Adjust the probe to the center of the standpipe.*
- *Make sure that there are no deposits at the bottom of the standpipe.*
- *Make sure that there is liquid in the standpipe.*

*Standpipes are not necessary for devices with coaxial probes. But if there is a sudden change in diameter in the standpipe, we recommend that you install a device with a coaxial probe.*

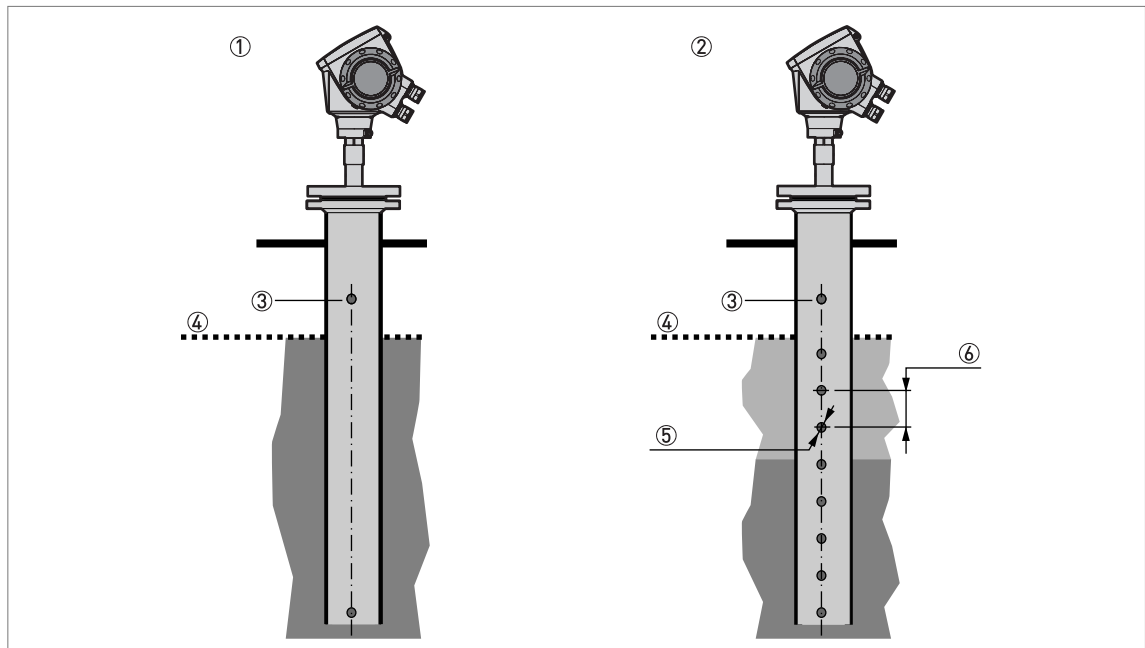

Figure 3-9: Installation recommendations for stilling wells

- ① Stilling well in tanks containing one liquid
- ② Stilling well in tanks containing more than one liquid
- ③ Air circulation hole
- ④ Maximum level of the liquid
- ⑤ Liquid circulation hole
- ⑥ Distance between holes  $\geq 25 \text{ mm} / 1''$  (depends on the minimum layer to be measured)

#### Installation in tanks containing one liquid and foam

- Drill a pressure equalization hole in the stilling well above the maximum level.
- Deburr the hole.
- If the probe has a counterweight, make sure that there is enough space between the counterweight and the wall of the stilling well.

#### Installation in tanks containing more than one liquid

- Drill a pressure equalization hole in the stilling well above the maximum level of the top liquid.
- Drill more holes along the length of the stilling well. Distance between holes  $\geq 25 \text{ mm} / 1''$  (depends on the minimum layer to be measured)
- ➡ These holes help the liquids to move freely.
- Deburr the holes.
- If the probe has a counterweight, make sure that there is enough space between the counterweight and the wall of the stilling well.

#### Floating roofs

If the device is for a tank with a floating roof, install it in a stilling well.

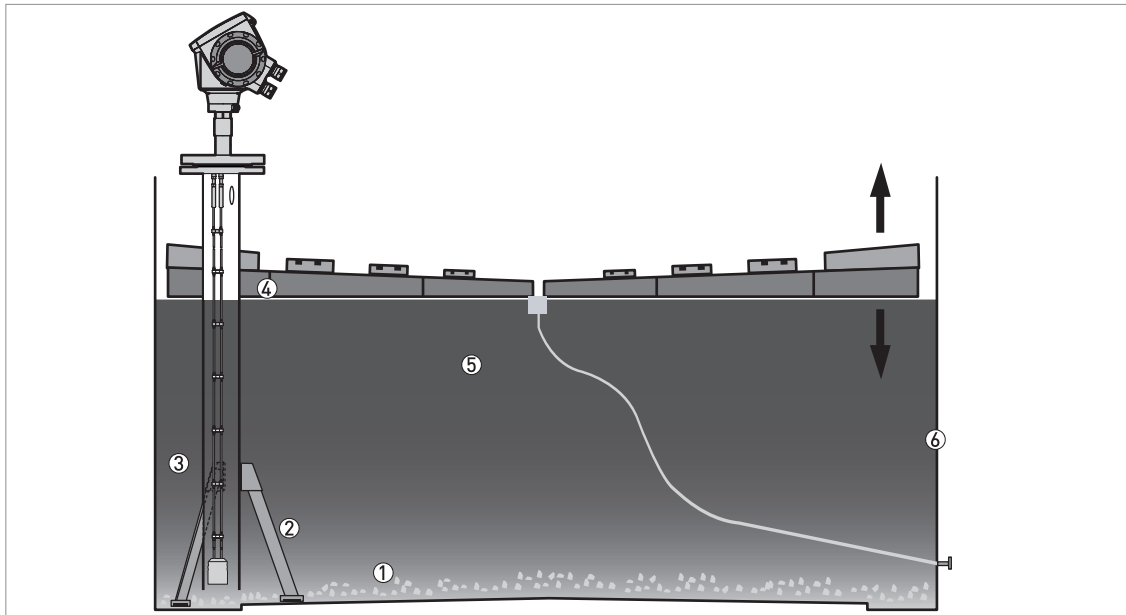

Figure 3-10: Floating roofs

- ① Sediment
- ② Support fixtures
- ③ Stilling well
- ④ Floating roof
- ⑤ Product
- ⑥ Tank

### Bypass chamber - general notes

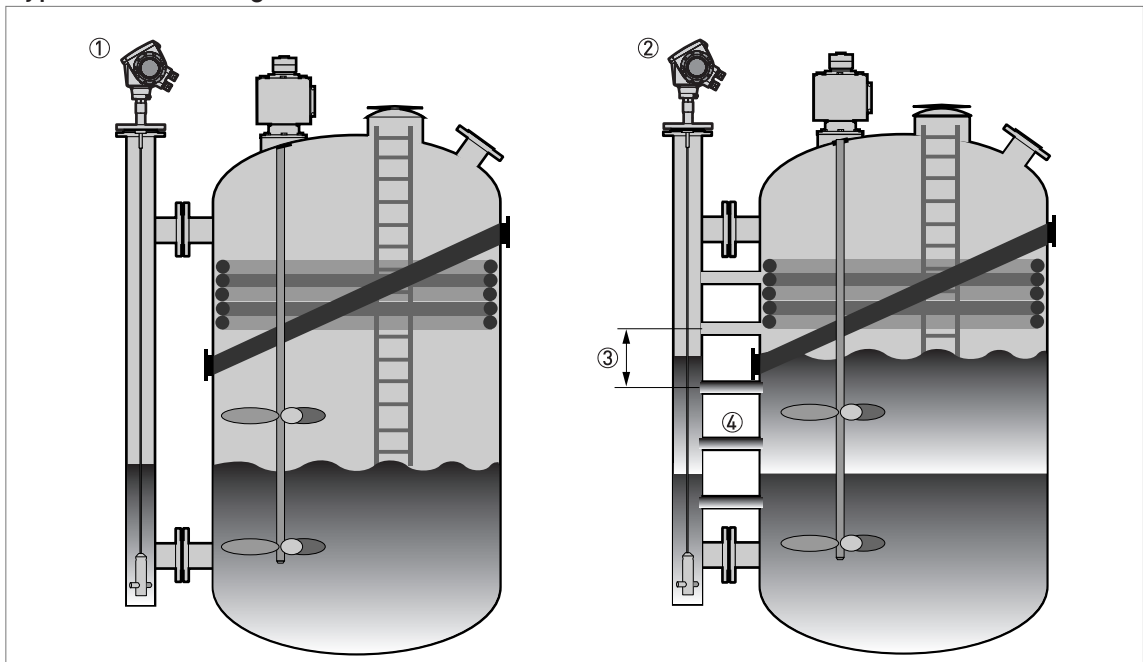

Figure 3-11: Installation recommendations for bypass chambers

- ① Bypass chamber for tanks that contain one liquid
- ② Bypass chamber for tanks that contain more than one liquid
- ③ Distance between holes  $\leq$  minimum level of each liquid in the tank
- ④ Additional process connection

### Installation on tanks containing one liquid and foam

- The bypass chamber must have a process connection that is above the maximum level of liquid.
- The bypass chamber must have a process connection that is below the lowest measured level of liquid.

### Installation on tanks containing more than one liquid

- The bypass chamber must have a process connection that is above the maximum level of liquid.
- The bypass chamber must have a process connection that is below the lowest measured level of liquid.
- There must be more process connections along the length of the bypass chamber. These must have a minimum diameter of 25 mm / 1" with a minimum distance of 100 mm / 4" between the holes.
- If the probe has a counterweight, make sure that there is enough space between the counterweight and the wall of the stilling well.
- If the interface liquid does not have a layer of air above it, fit a vent at the top of the bypass chamber. Refer to the illustration that follows:

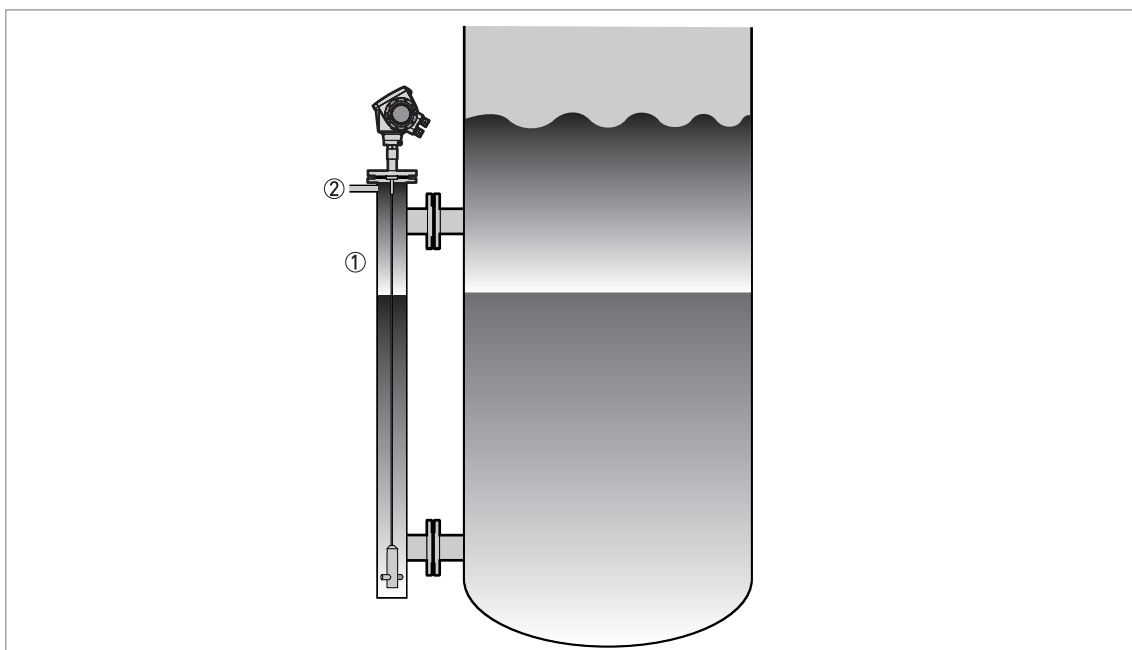

Figure 3-12: Installation recommendations for bypass chambers with no air gap

- ① Bypass chamber with no air gap
- ② Air vent



## 3.5 Installation recommendations for solids

### 3.5.1 Nozzles on conical silos

We recommend that you prepare the installation when the silo is empty.

*Risk of electrostatic discharge (ESD): The device is resistant to electrostatic discharges of up to 15 kV (30 kV with the ESD protection option – recommended for solid applications), but it is the responsibility of the fitter and the user to prevent ESD.*

*Install the device at the correct location to measure level correctly and prevent too much bending and traction. If necessary, attach the probe to the bottom of the tank.*

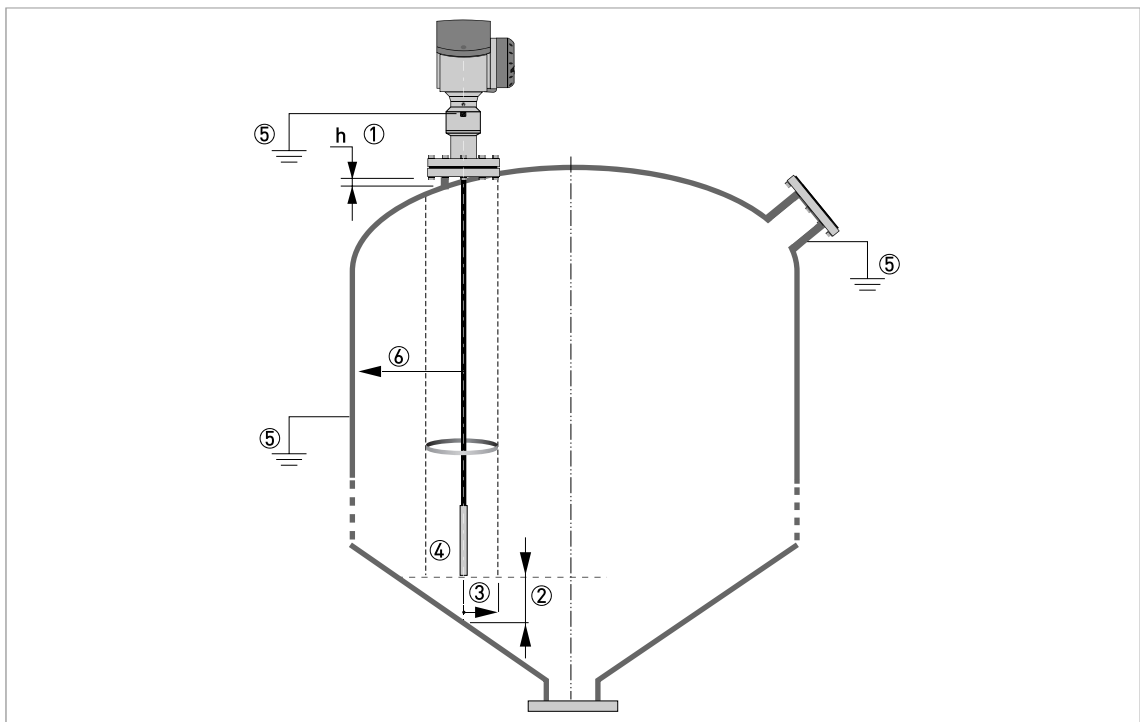

**Figure 3-13: Installation recommendations for solids**

- ① We recommend installation without a nozzle. If not,  $h \leq 50 \text{ mm} / 2''$ .
- ② The end of the probe must be more than 300 mm / 12" above the tank bottom.
- ③ Empty space (radius,  $R_{\min}$ ) around the probe.
- ④ The electromagnetic (EM) field generated by the device. It is also the measurement zone of the probe. Make sure that the EM field is clear of objects and product flow.
- ⑤ Ground the tank, the product and the probe (if attached).
- ⑥ If possible, put the process fitting  $\geq 300 \text{ mm} / 12''$  from the tank wall

### Clearance between the probe and other objects in the tank

Probe type	Empty space (radius, $R_{\min}$ ) around the probe	
	[mm]	[inches]
Single cable $\varnothing 4$ mm / 0.16" ④	300	12
Single cable $\varnothing 8$ mm / 0.32" ④	300	12

*If the probe is longer than 10 m / 33 ft, we recommend that you do not attach the end of the probe.*

### 3.5.2 Traction loads on the probe

#### Traction load depends on:

- The height and shape of the tank.
- The particle size and density.
- The rate at which the tank is emptied.

*Risk of damage to the cable probe. High loads can break the cable.*

*If the load on the  $\varnothing 8$  mm / 0.32" single cable probe is more than 3500 kg / 7700 lb, contact your supplier.*

*Make sure that the tank roof is resistant to deformation at high loads.*

#### Estimated traction load on the probe in kg

Material	Probe length, 10 m	Probe length, 20 m	Probe length, 30 m
	[kg]		
Cement	1000	2000	3000
Fly ash	500	1000	1500
Wheat	300	500	1200

#### Estimated traction load on the probe in lb

Material	Probe length, 33 ft	Probe length, 65 ft	Probe length, 98 ft
	[lb]		
Cement	2200	4410	6520
Fly ash	1100	2200	3300
Wheat	660	1100	2650

## 4.1 Electrical installation: outputs 1 and 2

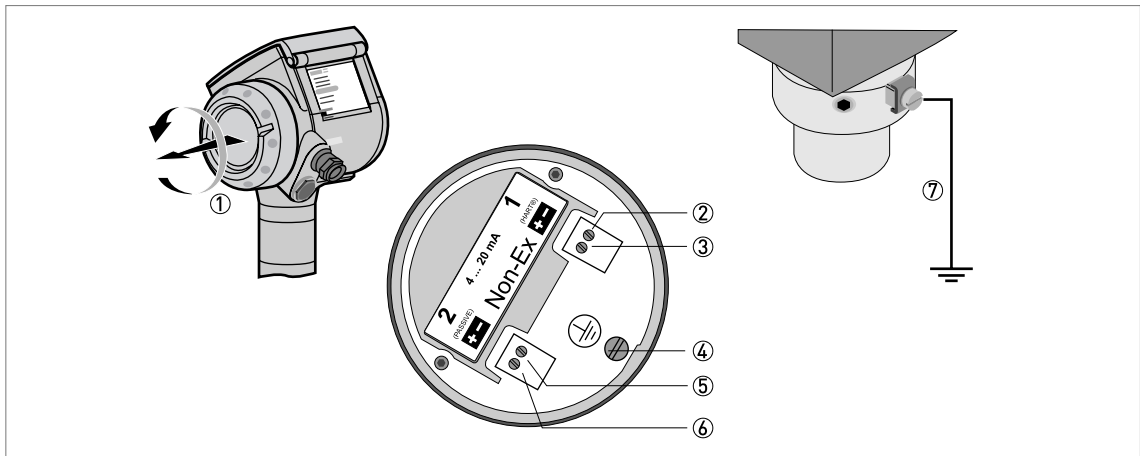

Figure 4-1: Electrical installation

- ① Terminal compartment cover
- ② Output 1: current output -
- ③ Output 1: current output +
- ④ Grounding terminal in the housing
- ⑤ Output 2: current output - (option)
- ⑥ Output 2: current output + (option)
- ⑦ Grounding terminal between the process connection and the converter

Output 1 energizes the device and is used for HART® communication. If the device has the second current output option, use a separate power supply to energize output 2.

*If the polarity is not correct, this will not cause damage to the device. But the device will not operate and the output will be 0 mA.*

### 4.1.1 Non-Ex devices

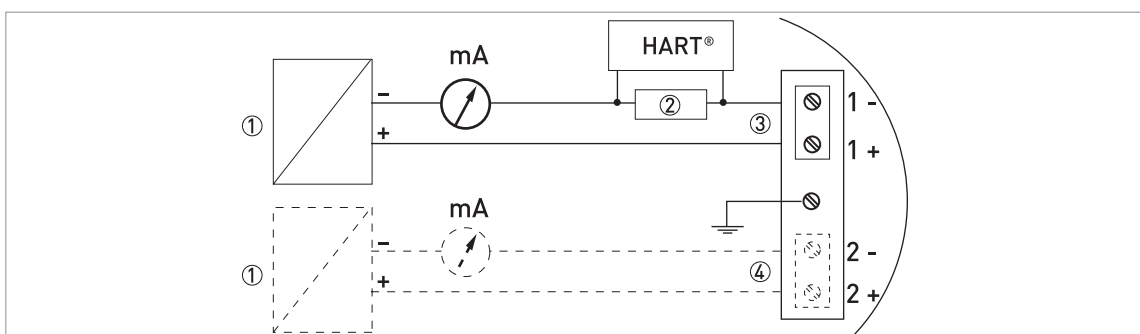

Figure 4-2: Electrical connections for non-Ex devices

- ① Power supply
- ② Resistor for HART® communication
- ③ Output 1: 14...30 VDC for an output of 22 mA at the terminal
- ④ Output 2: 10...30 VDC for an output of 22 mA at the terminal

### 4.1.2 Devices for hazardous locations

*For electrical data for device operation in hazardous locations, refer to the related certificates of compliance and supplementary instructions (ATEX, IECEx, FM, CSA etc.). You can find this documentation on the DVD-ROM delivered with the device or it can be downloaded free of charge from the website (Download Center).*

## 4.2 Protection category

*The device fulfils all requirements per protection category IP66 / IP67. It also fulfils all requirements per NEMA type 4X (housing) and type 6P (probe).*

*Make sure that the cable gland is watertight.*

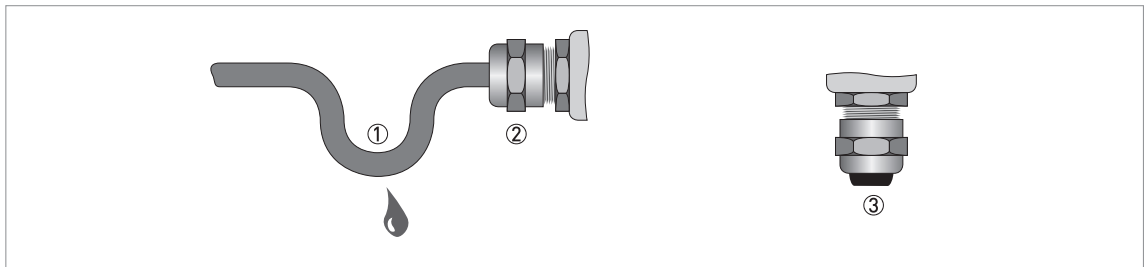

Figure 4-3: How to make the installation agree with protection category IP67

- Make sure that the gaskets are not damaged.
- Make sure that the electrical cables are not damaged.
- Make sure that the electrical cables agree with the national electrical code.
- The cables are in a loop in front of the device ① so water does not go into the housing.
- Tighten the cable feedthroughs ②.
- Close unused cable feedthroughs with dummy plugs ③.

## 4.3 Networks

### 4.3.1 General information

The device uses the HART® communication protocol. This protocol agrees with the HART® Communication Foundation standard. The device can be connected point-to-point. It can also have a polling address of 1 to 15 in a multi-drop network.

The device output is factory-set to communicate point-to-point. To change the communication mode from **point-to-point** to **multi-drop**, refer to "Network configuration" in the handbook.

### 4.3.2 Point-to-point networks

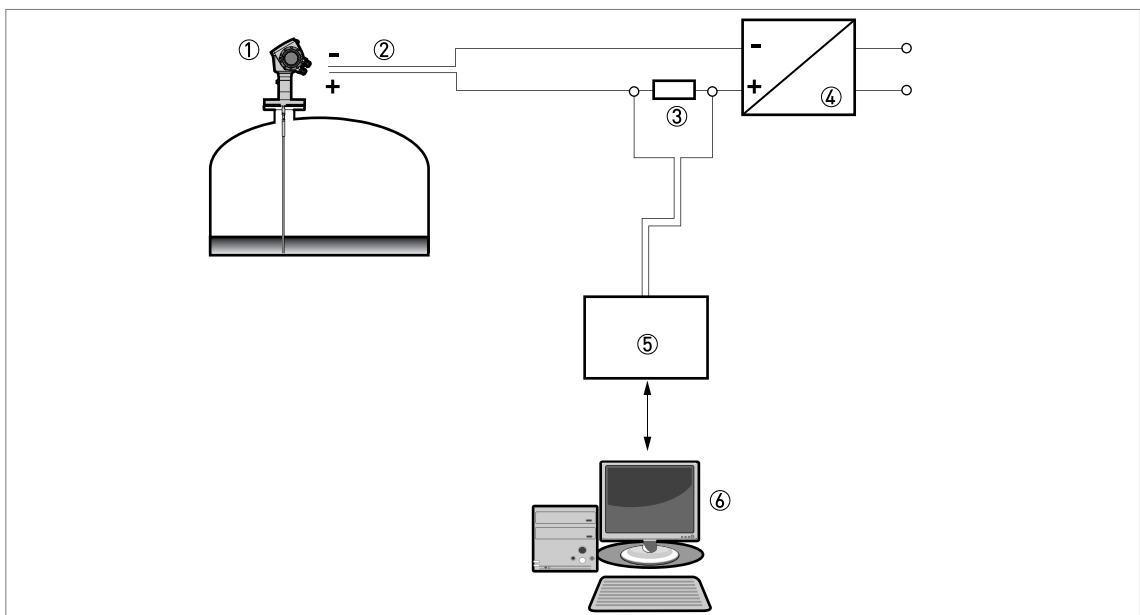

Figure 4-4: Point-to-point connection (non-Ex)

- ① Address of the device (0 for a point-to-point connection)
- ② 4...20 mA + HART®
- ③ Resistor for HART® communication
- ④ Power supply
- ⑤ HART® modem
- ⑥ HART® communication device

## 4.3.3 Multi-drop networks

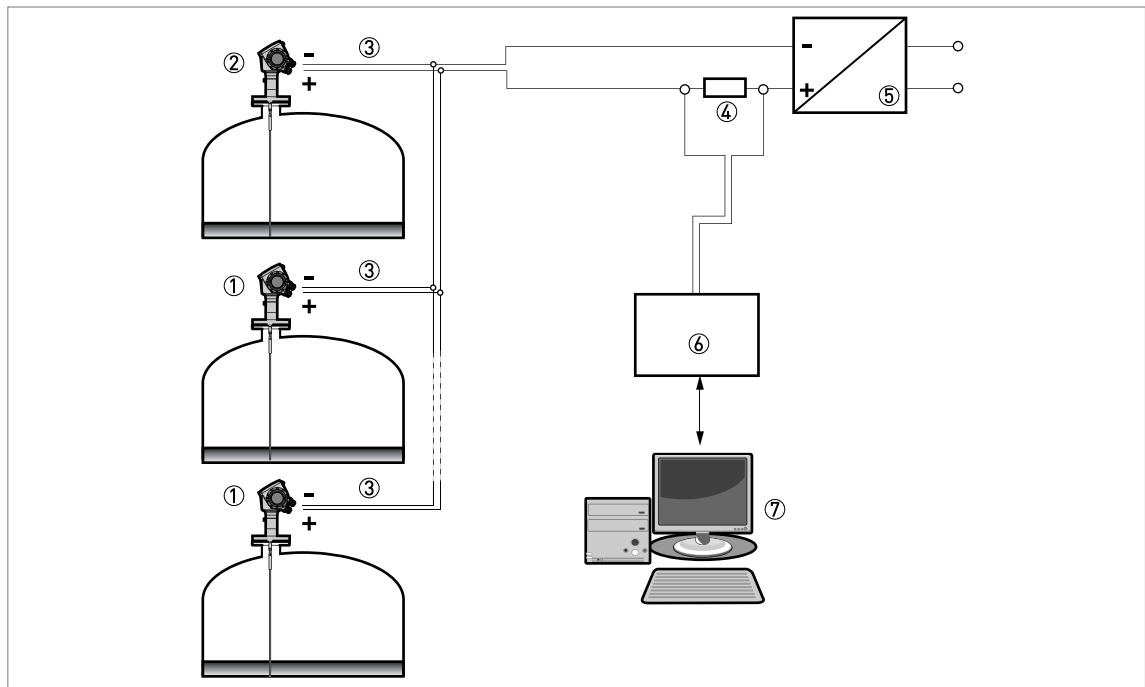

Figure 4-5: Multi-drop network (non-Ex)

- ① Address of the device (n+1 for multidrop networks)
- ② Address of the device (1 for multidrop networks)
- ③ 4 mA + HART<sup>®</sup>
- ④ Resistor for HART<sup>®</sup> communication
- ⑤ Power supply
- ⑥ HART<sup>®</sup> modem
- ⑦ HART<sup>®</sup> communication device

## 5.1 Order code

Make a selection from each column to get the full order code. The characters of the order code highlighted in light grey describe the standard.

### Ø2 mm / 0.08" single cable probe options

VF71	4	<b>OPTIFLEX 1300 C Guided Radar (TDR) level transmitter for heavy-duty and interface applications Ø2 mm (0.08") single cable – Standard (STD) / High Temperature (HT) / High Pressure (HP)</b>
		<b>Approval</b>
	0	Without
	1	WHG (overflow protection)
	2	ATEX II 1 G Ex ia IIC T6 Ga + II 1 D Ex ia IIIC Da
	3	ATEX II 1/2 G Ex ia/d IIC T6 Ga/Gb + II 1/2 D Ex ia tb IIIC Da/Db
	4	ATEX II 1 G Ex ia IIC T6 Ga + II 1 D Ex ia IIIC Da + WHG
	5	ATEX II 1/2 G Ex ia/d IIC T6 Ga/Gb + II 1/2 D Ex ia tb IIIC Da/Db + WHG
	6	FM IS CL I/II/III DIV 1 GPS A–G + CL I zone 0 Ex ia IIC T6
	7	FM XP-AIS/DIP/NI CL I/II/III Div 1 GPS A–G + CL I zone 1 / zone 2 Ex d[ia] / Ex nA[ia] IIC T6
	A	ATEX II 3 G Ex nA IIC T6 Gc (Zone 2)
	B	INMETRO Ex ia IIC T6 Ga + Ex ia IIIC Da
	C	INMETRO Ex d[ia Ga] IIC T6 Ga/Gb + Ex tb[ia Da] IIIC Db
	E	NEPSI Ex ia IIC T6 + DIP A21/A20 ①
	F	NEPSI Ex d ia IIC T6 + DIP A21/A20 ①
	H	CSA IS CL I/II/III DIV 1 GPS A–G + CL I zone 0 Ex ia IIC T6
	K	CSA XP-AIS/DIP/NI CL I/II/III DIV 2 GPS A–G + CL I zone 1 / zone 2 Ex d / Ex nA IIC T6 ①
	M	IECEX Ex ia IIC T6 Ga + Ex ia IIIC Da
	N	IECEX Ex ia/d IIC T6 Ga/Gb + Ex ia tb IIIC Da/Db
	R	KGS Ex ia IIC T6 + Ex iaD 20
	S	KGS Ex d[ia] IIC T6 + Ex tD[iaD] A21/20
		<b>Material of Process Connection and Probe / Pressure</b>
	0	316L (1.4404) / 40 barg (580 psig)
	1	HASTELLOY® C-22® (2.4602) / 40 barg (580 psig)
	2	316L (1.4404) / 100 barg (1450 psig)
	3	HASTELLOY® C-22® (2.4602) / 100 barg (1450 psig)
	4	316L (1.4404) / HP 300 barg (4351 psig)
	5	HASTELLOY® C-22® (2.4602) / HP 300 barg (4351 psig)
		<b>Probe type</b>
	6	Single cable Ø2 mm (0.08") max. 35 m (114.83 ft) – liquid only
	G	Single cable Ø2 mm (0.08") for BM 26 ADVANCED
	K	Single cable Ø2 mm (0.08") for BM 26 F
		<b>Probe end type</b>
	5	Counterweight Ø14 mm × 100 mm (Ø0.55" × 3.94") (single cable Ø2 mm (0.08"))
	L	Centering counterweight Ø20 mm × 100 mm (Ø0.79") for BM 26 F + BM 26 ADVANCED
VF71	4	<b>Order code (complete this code on the pages that follow)</b>

									<b>Feedthrough / Temperature / Sealing</b>
									2 Standard / -40...+150°C (-40...+302°F) / FKM/FPM
									3 Standard / -20...+150°C (-4...+302°F) / Kalrez 6375
									4 Standard / -50...+150°C (-58...+302°F) / EPDM
									5 Standard / HT -40...+300°C (-40...+572°F) / FKM/FPM
									6 Standard / HT -20...+300°C (-4...+572°F) / Kalrez 6375
									7 Standard / HT -50...+250°C (-58...+482°F) / EPDM
									<b>Process connection EN</b>
									0 Without
									2 G 1A ISO 228
									4 DN25 PN40 Type B1 EN 1092-1
									6 DN50 PN40 Type B1 EN 1092-1
									7 DN80 PN40 Type B1 EN 1092-1
									8 DN100 PN16 Type B1 EN 1092-1
									A DN100 PN40 Type B1 EN 1092-1
									B DN150 PN16 Type B1 EN 1092-1
									C DN150 PN40 Type B1 EN 1092-1
									D DN50 PN63 Type B1 EN 1092-1
									E DN80 PN63 Type B1 EN 1092-1
									F DN100 PN63 Type B1 EN 1092-1
									H G ½A ISO 228
									K DN25 PN63/PN100 Type B1 EN 1092-1
									L DN40 PN63/PN100 Type B1 EN 1092-1
									M DN50 PN100 Type B1 EN 1092-1
									N DN80 PN100 Type B1 EN 1092-1
									P DN100 PN100 Type B1 EN 1092-1 ②
									R DN150 PN63 Type B1 EN 1092-1 ②
									S DN150 PN100 Type B1 EN 1092-1 ②
									U DN 200 PN 16 Type B1 EN 1092-1
									V DN 200 PN 40 Type B1 EN 1092-1
VF71	4								<b>Order code (complete this code on the pages that follow)</b>







														<b>HMI (display and keys)</b>		
														0	Without	
														1	English	
														2	German	
														3	French	
														4	Italian	
														5	Spanish	
														6	Portuguese	
														7	Japanese	
														8	Chinese (simplified)	
														A	Russian	
														<b>Version</b>		
														0	KROHNE (RAL 9006 / RAL 5005)	
														A	KMIC L (for liquid applications)	
														<b>Special option</b>		
														0	Without	
														2	Metaglas® sealing	
														<b>Other approvals</b>		
														0	Without	
														B	EAC Russia	
														C	EAC Belarus	
														K	EAC Kazakhstan	
														<b>Calibration certificate</b>		
														0	Without	
														1	Calibration certificate 2 factory-default points for an accuracy of $\pm 3$ mm / $\pm 0.12$ " up to 10 m / 32.81 ft (minimum distance of first point: 300 mm / 11.81")	
														2	Calibration certificate 5 factory-default points for an accuracy of $\pm 3$ mm / $\pm 0.12$ " up to 10 m / 32.81 ft (minimum distance of first point: 500 mm / 19.69")	
														<b>Construction</b>		
														0	Without	
														3	NACE-Design (MR 0175 / MR 0103 / ISO 15156)	
														<b>Tag N°</b>		
														0	Without	
														2	Tag N° on stainless steel plate (18 characters max.)	
<b>VF71</b>														4		<b>Order code</b>

① DIP= Dust Ignition Proof

② Ex approvals are only available for HT, HP and HT/HP versions of the device with this flange option

## All other probe types

VF71	4	<b>OPTIFLEX 1300 C Guided Radar (TDR) level transmitter for heavy-duty and interface applications</b>
		<b>Approval</b>
	0	Without
	1	WHG (overfill protection)
	2	ATEX II 1 G Ex ia IIC T6 Ga + II 1 D Ex ia IIIC Da
	3	ATEX II 1/2 G Ex ia/d IIC T6 Ga/Gb + II 1/2 D Ex ia tb IIIC Da/Db
	4	ATEX II 1 G Ex ia IIC T6 Ga + II 1 D Ex ia IIIC Da + WHG
	5	ATEX II 1/2 G Ex ia/d IIC T6 Ga/Gb + II 1/2 D Ex ia tb IIIC Da/Db + WHG
	6	FM IS CL I/II/III DIV 1 GPS A-G + CL I zone 0 Ex ia IIC T6
	7	FM XP-AIS/DIP/NI CL I/II/III Div 1 GPS A-G + CL I zone 1 / zone 2 Ex d[ia] / Ex nA[ia] IIC T6
	A	ATEX II 3 G Ex nA IIC T6 Gc (Zone 2)
	B	INMETRO Ex ia IIC T6 Ga + Ex ia IIIC Da
	C	INMETRO Ex d[ia Ga] IIC T6 Ga/Gb + Ex tb[ia Da] IIIC Db
	E	NEPSI Ex ia IIC T6 + DIP A21/A20 ①
	F	NEPSI Ex d ia IIC T6 + DIP A21/A20 ①
	H	CSA IS CL I/II/III DIV 1 GPS A-G + CL I zone 0 Ex ia IIC T6
	K	CSA XP-AIS/DIP/NI CL I/II/III DIV 2 GPS A-G + CL I zone 1 / zone 2 Ex d / Ex nA IIC T6 ①
	M	IECEx Ex ia IIC T6 Ga + Ex ia IIIC Da
	N	IECEx Ex ia/d IIC T6 Ga/Gb + Ex ia tb IIIC Da/Db
	R	KGS Ex ia IIC T6 + Ex iaD 20
	S	KGS Ex d[ia] IIC T6 + Ex tD[iaD] A21/20
		<b>Material of Process Connection and Probe / Pressure</b>
	0	316L (1.4404) / 40 barg (580 psig)
	1	HASTELLOY® C-22® (2.4602) / 40 barg (580 psig) ②
	2	316L (1.4404) / 100 barg (1450 psig) ③
	3	HASTELLOY® C-22® (2.4602) / 100 barg (1450 psig) ②
VF71	4	<b>Order code (complete this code on the pages that follow)</b>

				<b>Probe type</b>
			0	Single rod Ø8 mm (0.32") max. 4 m (13.12 ft)
			1	Double rod Ø8 mm (0.32") max. 4 m (13.12 ft)
			2	Coaxial Ø22 mm (0.87") max. 6 m (19.69 ft)
			3	Single cable Ø4 mm (0.16") max. 35 m (114.83 ft)
			4	Single cable Ø8 mm (0.32") max. 35 m (114.83 ft)
			5	Double cable Ø4 mm (0.16") max. 8 m (26.25 ft)
			7	Single cable Ø4 mm (0.16") FEP coating 1 mm (0.04") max. 35 m (114.83 ft)
			8	Single rod Ø8 mm (0.32") + PVDF sheath max. 4 m (13.12 ft)
			A	No probe – (single rod Ø8 mm (0.32") max. 4 m (13.12 ft))
			B	No probe – (double rod Ø8 mm (0.32") max. 4 m (13.12 ft))
			C	No probe – (single cable Ø4 mm (0.16") max. 35 m (114.83 ft))
			D	No probe – (single cable Ø8 mm (0.32") max. 35 m (114.83 ft))
			E	No probe – (double cable Ø4 mm (0.16") max. 8 m (26.25 ft))
			H	Single cable Ø4 mm (0.16") for BM 26 ADVANCED
			L	Single cable Ø4 mm (0.16") for BM 26 F
			M	Single rod Ø8 mm (0.32") max. 6 m (19.69 ft) – segmented
			S	Coaxial Ø22 mm (0.87") max. 6 m (19.69 ft) – segmented
				<b>Probe end type</b>
			0	Without (rod and coaxial probes)
			1	Counterweight Ø12 mm × 100 mm (Ø0.47" × 3.94") (single cable Ø8 mm (0.32"))
			2	Counterweight Ø38 mm × 245 mm (Ø1.5" × 9.65") (single cable Ø8 mm (0.32"))
			3	Counterweight Ø20 mm × 100 mm (Ø0.79" × 3.94") (single cable Ø4 mm (0.16"))
			4	Counterweight Ø38 mm × 60 mm (Ø1.5" × 2.36") (double cable Ø4 mm (0.16"))
			A	Turnbuckle
			B	Chuck
			C	Threaded end
			D	Crimped end
			E	Open end
			L	Centering counterweight for BM 26 F + BM 26 ADVANCED
				<b>Feedthrough / Temperature / Sealing</b>
			0	Standard / -40...+200°C (-40...+392°F) / FKM/FPM
			1	Standard / -20...+200°C (-4...+392°F) / Kalrez 6375
			4	Standard / -50...+150°C (-58...+302°F) / EPDM ④
<b>VF71</b>	<b>4</b>			<b>Order code (complete this code on the pages that follow)</b>

		<b>Process connection EN</b>	
		0	Without
		1	G 3/4A ISO 228
		2	G 1A ISO 228
		3	G 1 1/2A ISO 228
		4	DN25 PN40 Type B1 EN 1092-1
		5	DN40 PN40 Type B1 EN 1092-1 / BM 26 Advanced
		6	DN50 PN40 Type B1 EN 1092-1
		7	DN80 PN40 Type B1 EN 1092-1
		8	DN100 PN16 Type B1 EN 1092-1
		A	DN100 PN40 Type B1 EN 1092-1
		B	DN150 PN16 Type B1 EN 1092-1
		C	DN150 PN40 Type B1 EN 1092-1
		D	DN50 PN63 Type B1 EN 1092-1
		E	DN80 PN63 Type B1 EN 1092-1
		F	DN100 PN63 Type B1 EN 1092-1
		K	DN25 PN63/PN100 Type B1 EN 1092-1
		L	DN40 PN63/PN100 Type B1 EN 1092-1
		M	DN50 PN100 Type B1 EN 1092-1
		N	DN80 PN100 Type B1 EN 1092-1
		P	DN100 PN100 Type B1 EN 1092-1 ⑤
		R	DN150 PN63 Type B1 EN 1092-1 ⑤
		S	DN150 PN100 Type B1 EN 1092-1 ⑤
		U	DN 200 PN 16 Type B1 EN 1092-1
		V	DN 200 PN 40 Type B1 EN 1092-1
<b>VF71</b>	<b>4</b>	<b>Order code (complete this code on the pages that follow)</b>	

									<b>Process connection ASME</b>
									0 Without
									1 3/4 NPT
									2 1 NPT
									3 1 1/2 NPT
									4 1" 150 lb RF ASME B16.5
									5 1 1/2" 150 lb RF ASME B16.5
									6 1 1/2" 300 lb RF ASME B16.5
									7 2" 150 lb RF ASME B16.5
									8 2" 300 lb RF ASME B16.5
									A 3" 150 lb RF ASME B16.5
									B 3" 300 lb RF ASME B16.5
									C 4" 150 lb RF ASME B16.5
									D 4" 300 lb RF ASME B16.5
									E 6" 150 lb RF ASME B16.5
									F 8" 150 lb RF ASME B16.5
									G 6" 300 lb RF ASME B16.5 (5)
									K 1" 300 lb RF ASME B16.5
									L 2" 300 lb process connection / BM 26 F
									M 1" 600 lb RF ASME B16.5
									N 1 1/2" 600 lb RF ASME B16.5
									P 2" 600 lb RF ASME B16.5
									R 3" 600 lb RF ASME B16.5
									S 4" 600 lb RF ASME B16.5 (5)
									T 1" 900/1500 lb RJ ASME B16.5
									U 1 1/2" 900/1500 lb RJ ASME B16.5
									V 2" 900/1500 lb RJ ASME B16.5 (5)
									W 3" 900 lb RF ASME B16.5 (5)
									X 4" 900 lb RF ASME B16.5 (5)
								<b>Process connection other</b>	
									0 Without
									3 RJ (ring joint)
									5 10K 40A RF JIS B2220
									6 10K 50A RF JIS B2220
									7 10K 80A RF JIS B2220
									8 10K 100A RF JIS B2220
									V Type C (EN 1092-1) tongue
									W Type D (EN 1092-1) groove
									X Type E (EN 1092-1) spigot
									Y Type F (EN 1092-1) recess
<b>VF71</b>	<b>4</b>								<b>Order code (complete this code on the pages that follow)</b>

											<b>Output</b>	
											0	1 output: 4...20 mA (HART®)
											1	1 output: 4...20 mA (HART®) – INTERFACE
											2	2 outputs: 4...20 mA (HART®) + 4...20 mA
											3	2 outputs: 4...20 mA (HART®) + 4...20 mA – INTERFACE
											<b>Housing / Cable entry / Cable gland</b>	
											0	Aluminium / M20 × 1.5 (nickel-plated brass adaptor) / without
											1	Aluminium / ½ NPT (nickel-plated brass adaptor) / without
											2	Aluminium / G ½ (nickel-plated brass adaptor) / without
											3	Aluminium / M20 × 1.5 (nickel-plated brass adaptor) / plastic (non-Ex: black, Ex ia: blue)
											4	Aluminium / M20 × 1.5 (nickel-plated brass adaptor) / metal (only for Ex d)
											A	Stainless steel / M25 × 1.5 (stainless steel adaptor) / without
											B	Stainless steel / ½ NPT (stainless steel adaptor) / without
											D	Stainless steel / M25 × 1.5 (stainless steel adaptor) / plastic M20 (non-Ex: black, Ex ia: blue)
											E	Stainless steel / M25 × 1.5 (stainless steel adaptor) / metal M20 (only for Ex d)
											<b>Housing option</b>	
											0	Without
											2	Stainless steel weather protection
											3	Remote version with 50-ohm cable / 2 m (2180 mm) / 6.56 ft (85.83")
											4	Remote version with 50-ohm cable / 4.5 m (4720 mm) / 14.76 ft (185.83")
											5	Remote version with 50-ohm cable / 9.5 m (9800 mm) / 31.17 ft (385.83")
											6	Remote version with 50-ohm cable / 14.5 m (14880 mm) / 47.57 ft (585.83")
											A	Remote version with 50-ohm cable / 2 m (2180 mm) / 6.56 ft (85.83") + stainless steel weather protection
											B	Remote version with 50-ohm cable / 4.5 m (4720 mm) / 14.76 ft (185.83") + stainless steel weather protection
											C	Remote version with 50-ohm cable / 9.5 m (9800 mm) / 31.17 ft (385.83") + stainless steel weather protection
											D	Remote version with 50-ohm cable / 14.5 m (14880 mm) / 47.57 ft (585.83") + stainless steel weather protection
<b>VF71</b>	<b>4</b>										<b>Order code (complete this code on the pages that follow)</b>	



		<b>HMI (display and keys)</b>	
		0	Without
		1	English
		2	German
		3	French
		4	Italian
		5	Spanish
		6	Portuguese
		7	Japanese
		8	Chinese (simplified)
		<b>Version</b>	
		0	KROHNE (RAL 9006 / RAL 5005)
		<b>Special option</b>	
		0	Without
		1	ESD protection 30 kV
		<b>Other approval</b>	
		0	Without
		B	EAC Russia
		C	EAC Belarus
		<b>Calibration certificate</b>	
		0	Without
		1	Calibration certificate 2 factory-default points for an accuracy of $\pm 3$ mm / $\pm 0.12''$ up to 10 m / 32.81 ft <sup>⑥</sup>
		2	
		Calibration certificate 5 factory-default points for an accuracy of $\pm 3$ mm / $\pm 0.12''$ up to 10 m / 32.81 ft <sup>⑦</sup>	
		<b>Construction</b>	
		0	Without
		3	
		NACE-Design (MR 0175 / MR 0103 / ISO 15156)	
		<b>Tag N°</b>	
		0	Without
		2	Tag N° on stainless steel plate (18 characters max.)
<b>VF71</b>	<b>4</b>	<b>Order code</b>	

① DIP= Dust Ignition Proof

② Not available for single cable  $\varnothing 8$  mm (0.32") and double cable  $\varnothing 4$  mm (0.32") probes

③ Not available for the single cable  $\varnothing 8$  mm (0.32") probe

④ This option is not available for the single cable  $\varnothing 8$  mm (0.32") probe)

⑤ This flange option is applicable only to non-Ex devices

⑥ Minimum distance of first point: 400 mm / 15.75" (coaxial probe) or 500 mm / 19.69" (other probes)

⑦ Minimum distance of first point: 1000 mm / 39.37" (coaxial probe) or 500 mm / 19.69" (other probes)





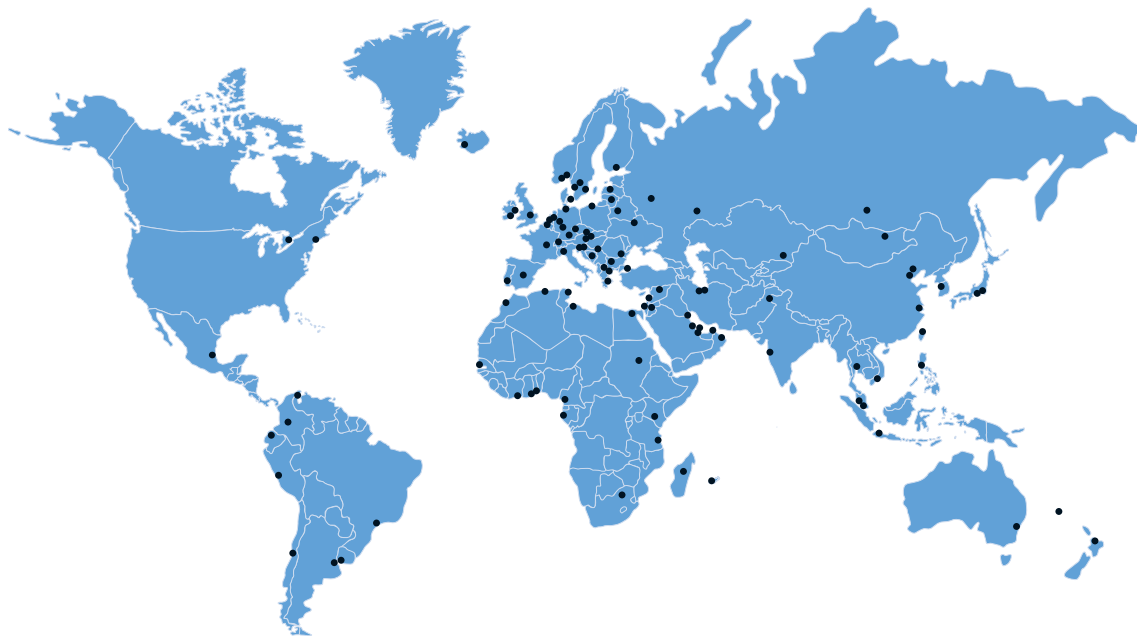

## KROHNE – Process instrumentation and measurement solutions

- Flow
- Level
- Temperature
- Pressure
- Process Analysis
- Services

Head Office KROHNE Messtechnik GmbH  
Ludwig-Krohne-Str. 5  
47058 Duisburg (Germany)  
Tel.: +49 203 301 0  
Fax: +49 203 301 10389  
info@krohne.com

The current list of all KROHNE contacts and addresses can be found at:  
[www.krohne.com](http://www.krohne.com)

**KROHNE**