

Stafsjö
SINCE 1666

WB14E

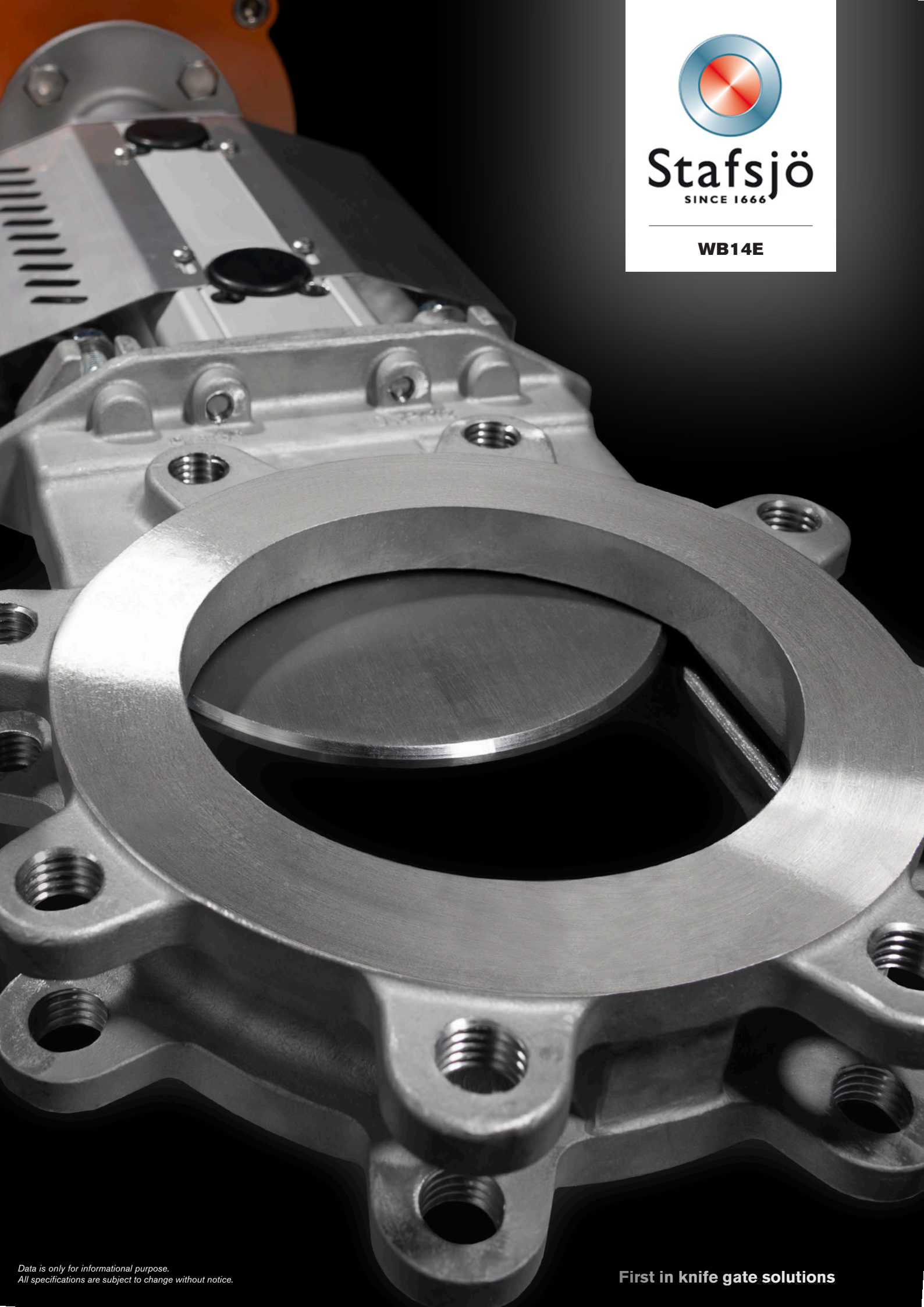

*Data is only for informational purpose.
All specifications are subject to change without notice.*

First in knife gate solutions

Knife gate valve WB14E

Stafsjö's WB14E knife gate valve is a high performance shut-off valve with superior flow characteristics, offering bi-directional zero leakage shut-off up to 10 bar/150 psi. It is suitable for fluids such as pulp stock, chemicals, sludge, bio mass, light slurries and water. The fully lugged body design is suitable for dead-end services.

The WB14E valve is modular designed and it can easily be customized in materials, with actuators and related automation accessories to different process conditions. The valve is also available with mechanical lock out. As standard the WB14E is supplied with stainless steel wetted parts including the fully lugged valve body, polished gate and gland. Up to DN 300 it has a one piece valve body and from DN 350 it features a rigid two piece version. The WB14E sealing system assure a first rate sealing both internal and external against surrounding environment.



Product features

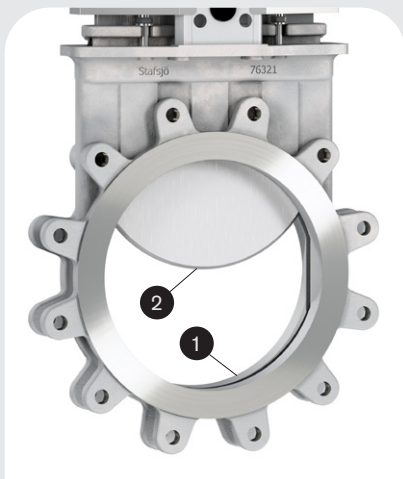

Full bore with superior flow characteristics

The cavity free bore (1) prevent any build up of media during operation. The polished gate (2) with the dual bevel edge and reduced gate arc profile make it easy for the gate to cut through the media. The design also prevents media from wedging between the gate and body as the valve closes.

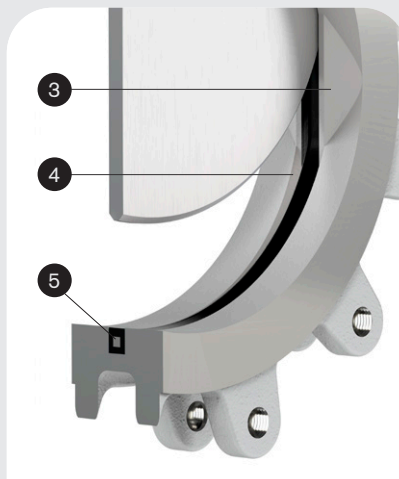

Bi-directional zero leakage shut-off

Gate guides (3) support the gate through the entire range of travel. In bottom of the guides, the relief areas (4) promote a self-cleaning, flushing action as the gate moves into the final stage of closure. The perimeter resilient seat provides tight shut-off in both directions. The seat is also reinforced with a stainless steel core (5) to enhance durability.

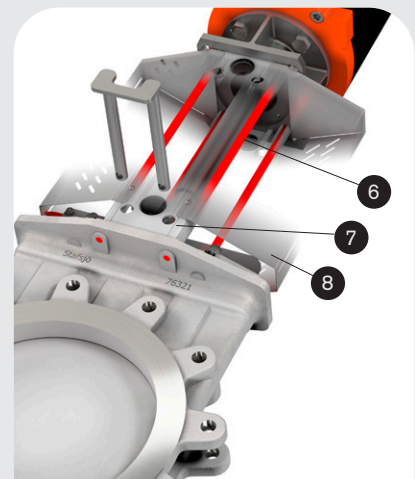

High strength top works

Smooth cycling and a tight shut-off independent of valve position is achieved by the high strength top works that provide an essential alignment for the gate. It utilizes stainless steel tie rods (6) encapsulated inside the structural beams (7). Stafsjö assemble stainless steel gate guards (8) as standard on all automated valves.

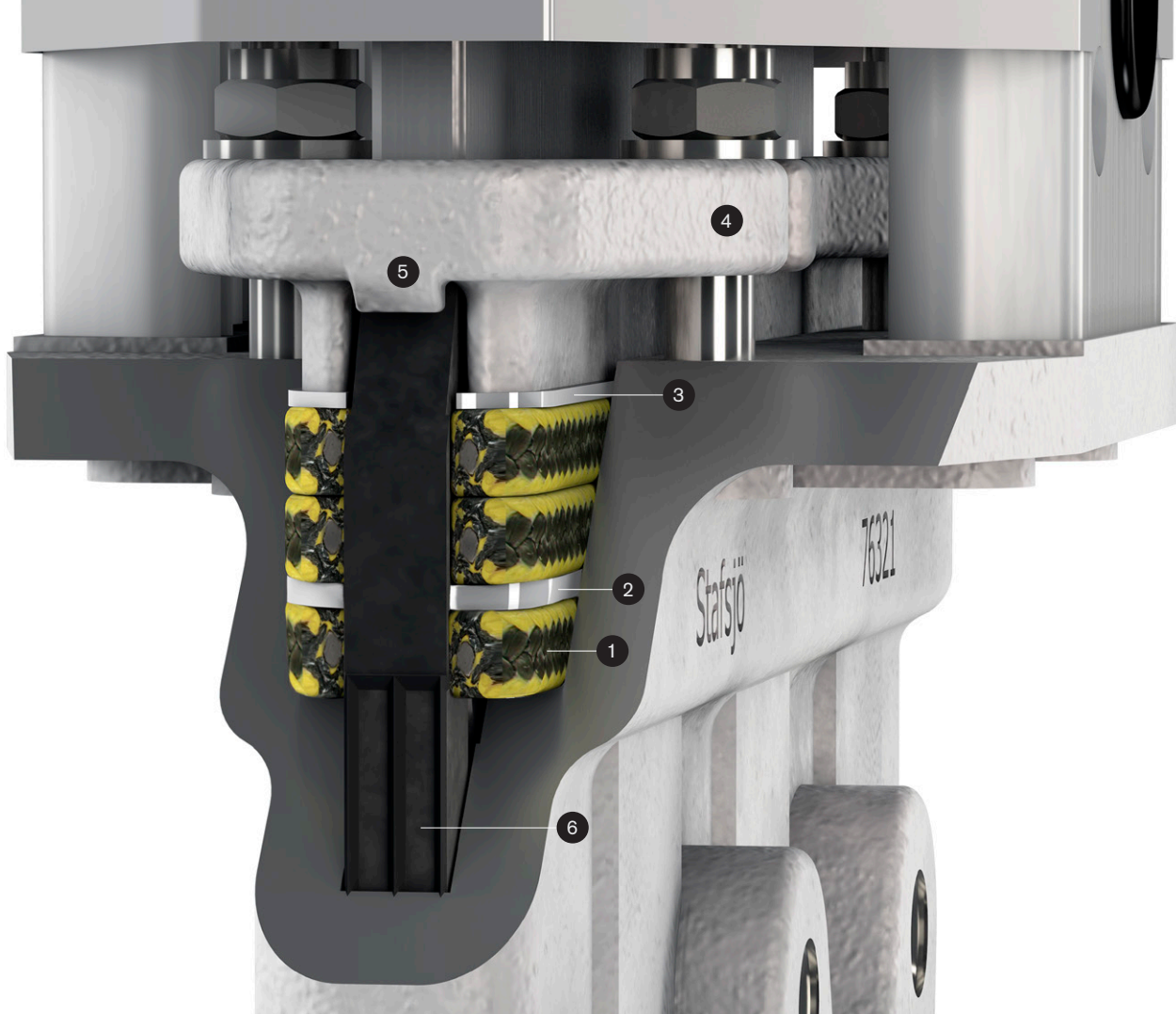

The WB14E sealing system

The WB14E valve is intended for use in a wide range of applications. A first rate sealing both internal and external is crucial for both plant efficiency and personnel safety. The sealing system consist of several features and components, all working together to perform during long periods of time and to provide a tight shut-off.

Stafsjö's TwinPack braids (1) perform the main external sealing operation in the system and offers high mechanical strength and excellent chemical resistance. It is made up by an elastic silicon rubber core surrounded by interlocked graphite filled PTFE fibres with additional strong interlocked aramide fibre reinforced corners (yellow). The TwinPack braids resist pH 2-13 and temperatures -60 °C up to 260 °C. The additional PTFE scraper (2) in between

the braids and on top (3) further reinforce the packings scraping function.

The gland (4) and gland bolts ensure even distribution of the gland force as the nuts are tightened. The linear locks (5) on the gland up to DN 300 securely hold the steel reinforced seat in position as the gate strokes. From DN 350 the seat is locked between the valve body halves.

The unique flexible profile (6) on the outside surface of the seat up to DN 300 energizes sealing, reducing friction and providing longer cycle life while the internal stainless steel reinforcement enhance the durability.

The WB14E valve can be supplied with seat in EPDM, Nitrile and the high temperature and chemical resistant FEPM (Fluoroelastomer) material.

FEPM -10 °C - + 180 °C

Excellent resistance to wide range of aggressive chemicals, both acids and bases, and steam at high continuous service temperatures including short term peaks up to + 225 °C

Unsuitable media and service

Limited resistance to mineral and aromatic oils and low temp.

EPDM -25 °C - + 120 °C

An allround durable chemical resistance rubber suitable for rather high media temperatures.

Unsuitable media and service

Petroleum (gasoline, kerosene, oil and grease) and sulphuric acid.

Nitrile -25 °C - + 100 °C

Alternative to EPDM with excellent resistance to petroleum (gasoline, oil, grease).

Unsuitable media and service

Chlorinated solvents, acetone, sulphuric acid, formic acid.

Pressure class

Max working pressure at 20 °C		Max differential pressure at 20 °C	
DN	bar	DN	bar
80 - 600	10	80 - 300	10
		350 - 450	6 or 10
		500 - 600	4 or 10

WB14E configurations

Standard version	High pressure 10 bar version
<p>Sizes: DN 80 - DN 600</p> <p>Valve body: Stainless steel EN 1.4408</p> <p>Gate: Stainless steel EN 1.4404, AISI 316L</p> <p>Box packing: TwinPack with extra PTFE scrapers</p> <p>Top works: Stainless steel tie rods encapsulated in aluminum beams including stainless steel gate guards on automated valves</p> <p>Options and others from below</p>	<p>Sizes: DN 350 - DN 600</p> <p>Valve body: Stainless steel EN 1.4408</p> <p>Gate: Duplex stainless steel EN 1.4462, S32205</p> <p>Box packing: TwinPack with extra PTFE scrapers</p> <p>Top works: Stainless steel tie rods encapsulated in aluminum beams including stainless steel gate guards on automated valves</p> <p>Options and others from below</p>

Options

Valve body

Stainless steel EN 1.4408 (Max +400 °C)
 DN 350-DN 600: Duplex stainless steel EN 1.4470 (Max +250 °C)
 DN 350-DN 600: 254 SMO Stainless steel (Max +399 °C)

Gate material and surface treatments

Stainless steel EN 1.4404, AISI 316L
 Duplex stainless steel EN 1.4462, S32205
 254 SMO stainless steel
 Hard chromed surface
 Extra polished surface (max Ra 0,8)

Valve seat

FEPM, EPDM or Nitrile

Box packings

TwinPack with extra PTFE scrapers
 Top scraper in PTFE is optional

Top works

Stainless steel tie rods encapsulated in aluminum beams
 Stainless steel pillars¹⁾ or beams

Actuators

Hand wheel with non-rising stem
 Chain wheel
 Hand lever
 Ratchet wrench
 Bevel gear
 Double-acting pneumatic cylinders
 Single-acting pneumatic cylinders
 Electric actuators
 Hydraulic actuator

Flange drillings

EN 1092 PN 10
 ASME/ANSI B16.5 Class 150
 AS 2129 Table D and E

Accessories

Limit switches, solenoid valves, mechanical lockouts, stem extensions etc. See our accessory data sheet for further information.

Design standards

Face-to-face dimensions

According to MSS-SP81.

Design, manufacturing, inspection and test

According to pressure equipment directive 2014/68/EU category I and II module A2. The valves are CE marked when it is applicable. The WB14E meets the requirements of MSS SP-81.

Stafsjö's valves are subject for pressure tests before delivery in opened and closed position with water at 20 °C according to EN 12266-1:2003 rate A. No visually detectable leakage is allowed for duration of the test.

On request 2.2 test report and 3.1 inspection certificate.

ATEX designs

On request directive 2014/34/EU Group II category:
 3 G/D (zone 2 or 22)
 2 G/D (zone 1 or 21)
 1 D (Zone 20)

One piece valve body: DN 80 - DN 300

Two piece valve body: DN 350 - DN 600

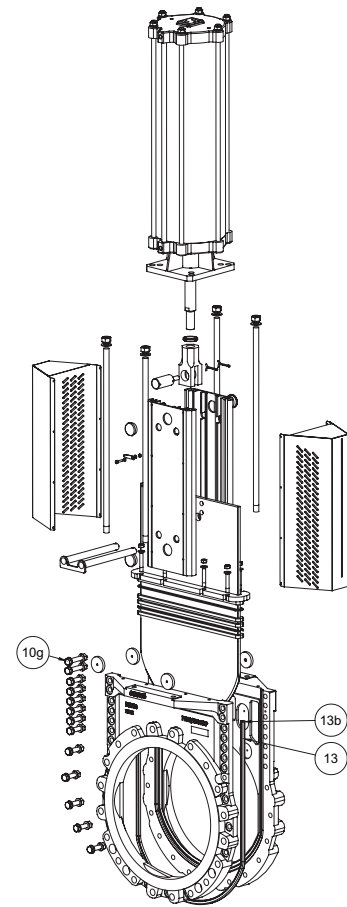
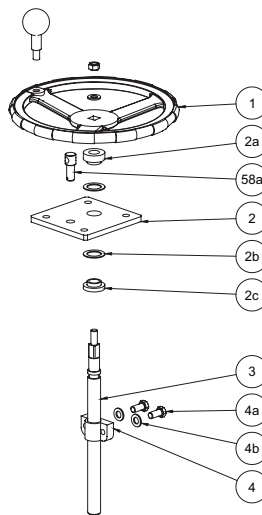
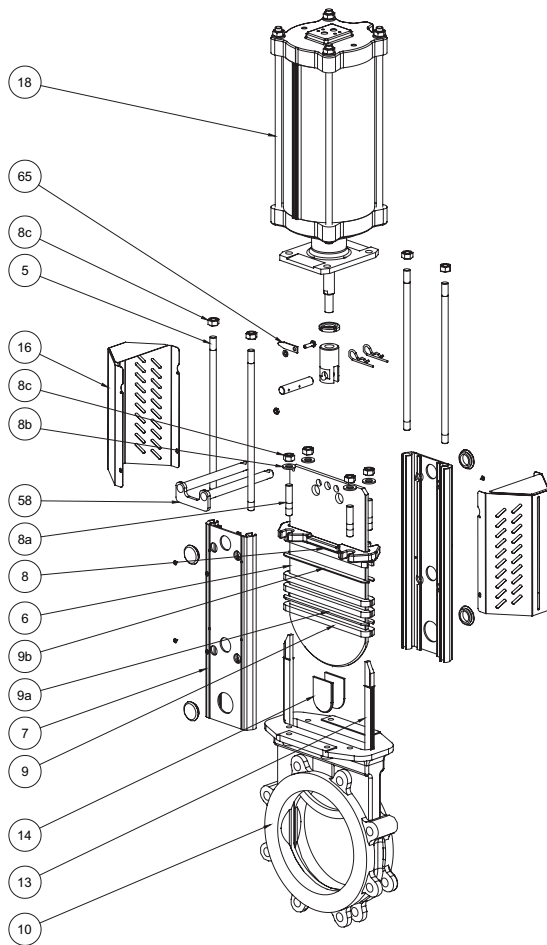

Part list

Pos.	Part	Material (Name)
1	Hand wheel	Coated cast iron Ø 200 - Ø 300 EN-JL1040, GG25, ≥ Ø 400 EN-JL1030, GG20
2	Yoke	Stainless steel EN 1.4301
2a	Bearing	Brass
2b	Slide washer	POM
2c	Bearing	Brass
3	Stem	Stainless steel EN 1.4016
4	Stem nut	Brass
4a	Washer	Stainless steel A2
4b	Bolt	Stainless steel A2
5	Tie rod	Stainless steel EN 1.4301
6	Gate	See options on page 4
7	Beam	Aluminum
8	Gland	Stainless steel EN 1.4408
8a	Stud bolt	Stainless steel A2

Pos.	Part	Material (Name)
8b	Washer	Stainless steel A2
8c	Nut	Stainless steel A2
9 ¹⁾	Box packing	See options on page 4
9a ¹⁾	Box scraper	See options on page 4
9b ^{1,2)}	Box top scraper	See options on page 4
10	Valve body	See options on page 4
10g	Valve body boltings	Stainless steel A2
13 ¹⁾	Seat	See options on page 4
13b ¹⁾	Pin short	Stainless steel EN 1.4301
14	Guiding pads	POM max 120 °C, PTFE on request.
16	Gate guards	Stainless steel EN 1.4301
18	Pneumatic cylinder	See separate datasheet
58/a ²⁾	Locking pin	Stainless steel EN 1.4301
65 ²⁾	Gate indicator	Stainless steel EN 1.4301, Nylon 12

¹⁾ Recommended spare parts

²⁾ Accessories

One piece valve body: DN 80 - DN 300

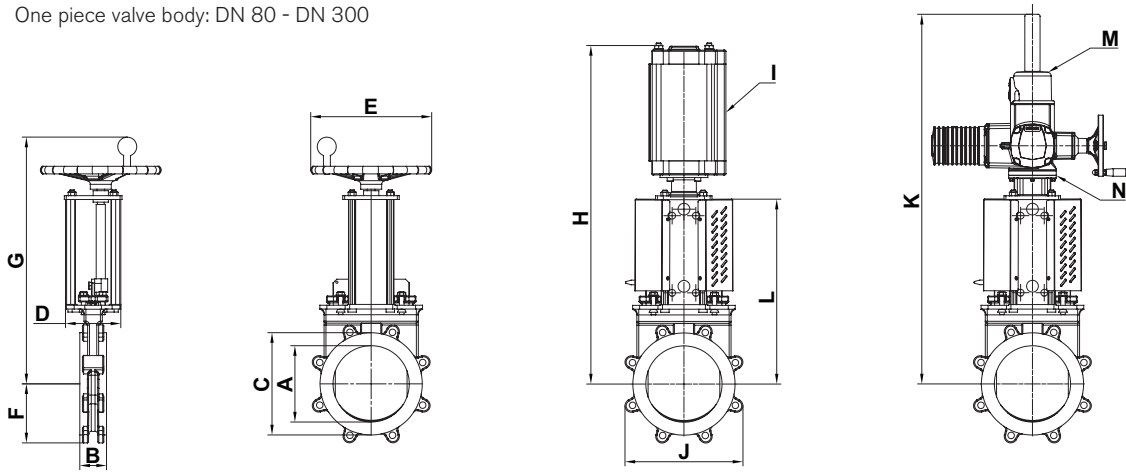

Two piece valve body: DN 350 - DN 600

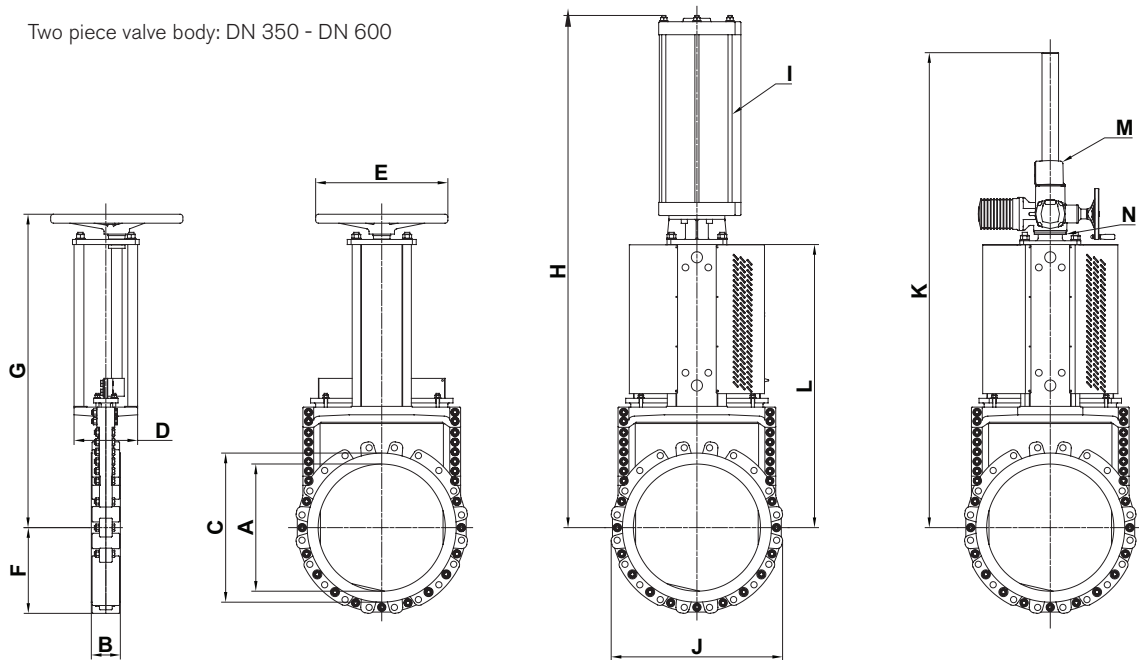

Main dimensions (mm)

DN	A	B	C	D	E	F	G	H ¹⁾	H ²⁾	I ³⁾	I ⁴⁾	J	K	L	M ⁵⁾	N ⁶⁾	kg ⁷⁾
80	80	51	127	80	250	69	346	574	-	SC100	-	137	677	275	SA07.2	F10/A	12
100	100	52	153	80	250	102	381	702	-	SC125	-	204	712	310	SA07.2	F10/A	15
125	125	56	169	86	250	112	421	742	-	SC125	-	236	752	350	SA07.2	F10/A	18
150	150	56	212	80	250	128	464	784	-	SC125	-	256	794	392	SA07.6	F10/A	22
200	200	70	268	145	315	155	561	960	-	SC160	-	310	818	489	SA07.6	F10/A	37
250	250	69	320	145	315	194	657	1155	-	SC160	-	388	914	579	SA07.6	F10/A	55
300	300	78	372	148	315	231	753	1251	-	SC160	-	462	1059	675	SA10.2	F10/A	71
350	350	78	430	180	400	251	880	1543	1543	SC200	SC200	501	1228	783	SA10.2	F10/A	115
400	400	89	482	180	400	285	977	1640	1640	SC200	SC250	570	1375	880	SA10.2	F10/A	155
450	450	89	532	250	520	308	1153	1896	1896	SC200	SC250	615	1636	1034	SA10.2	F10/A	230
500	500	114	586	250	520	338	1225	2103	2103	SC250	SC250	675	1875	1113	SA14.2	F14/A	270
600	600	114	686	250	520	400	1436	2307	2403	SC250	SC320	800	2180	1317	SA14.2	F14/A	400

1) Dimensions standard version. Dimensions WB14E DN 350 - DN 450 6 bar version and DN 500 - DN 600 4 bar version.

2) Dimensions 10 bar version DN 350 - DN 600.

3) Standard version: Recommended sizing of double-acting pneumatic cylinder type SC at normal operation with 5 bar air pressure. For other operating conditions, contact Stafsjö for advice.

4) 10 bar version DN 350-DN 600: Recommended sizing of double-acting pneumatic cylinder type SC at normal operation with 5 bar air pressure. For other operating conditions, contact Stafsjö for advice.

5) Recommended sizing of Auma SA electric motors at normal operation. For other operating conditions, contact Stafsjö or your local representative for advice.

6) Valve and Auma SA interface. The electric motors are mounted as standard according to ISO 5210 connection A (rising stem).

7) Weight in kg for valve equipped with hand wheel.

Main dimensions are only for information. Contact Stafsjö for certified drawings.

Flange drilling according to ASME/ANSI B 16.5 Class 150

DN	80	100	125	150	200	250	300	350	400	450	500	600
Bolt circle diameter (mm)	152,4	190,5	215,9	241,3	298,4	361,9	431,8	476,3	539,8	577,9	635	749,3
Number of throughgoing bolts	-	-	-	-	-	-	-	-	-	-	-	-
Number of tapped holes/side	4	8	8	8	8	12	12	12	16	16	20	20
Bolt size (UNC)	5/8-11	5/8-11	3/4-10	3/4-10	3/4-10	7/8-9	7/8-9	1-8	1-8	1 1/8-7	1 1/8-7	1 1/4-7
Bolt lengths ¹⁾ (mm)	14	15	15	15	23	20	21	21	27	27	32	32

Flange drilling according to EN 1092 PN10

DN	80	100	125	150	200	250	300	350	400	450	500	600
Bolt circle diameter (mm)	160	180	210	240	295	350	400	460	515	565	620	725
Number of throughgoing bolts	-	-	-	-	-	-	-	-	-	-	-	-
Number of tapped holes/side	8	8	8	8	8	12	12	16	16	20	20	20
Bolt size	M16	M16	M16	M20	M20	M20	M20	M20	M24	M24	M24	M27
Bolt lengths ¹⁾ (mm)	11	15	15	15	18	20	21	19	27	29	32	32

Flange drilling according to AS 2129 Table D

DN	80	100	125	150	200	250	300	350	400	450	500	600
Bolt circle diameter (mm)	146	178	210	235	292	356	406	470	521	584	641	756
Number of throughgoing bolts	-	-	-	-	-	-	-	-	-	-	-	-
Number of tapped holes/side	4	4	8	8	8	8	12	12	12	12	16	16
Bolt size	M16	M16	M16	M16	M16	M20	M20	M24	M24	M24	M24	M27
Bolt lengths ¹⁾ (mm)	11	15	15	15	18	20	21	21	27	27	32	32

Flange drilling according to AS 2129 Table E

DN	80	100	125	150	200	250	300	350	400	450	500	600
Bolt circle diameter (mm)	146	178	210	235	292	356	406	470	521	584	641	756
Number of throughgoing bolts	-	-	-	-	-	-	-	-	-	-	-	-
Number of tapped holes/side	4	8	8	8	8	12	12	12	12	16	16	16
Bolt size	M16	M16	M16	M20	M20	M20	M24	M24	M24	M24	M24	M30
Bolt lengths ¹⁾ (mm)	11	15	15	15	18	20	21	21	27	27	32	32

¹⁾ Add the values with the thickness of flanges, washers and gaskets.

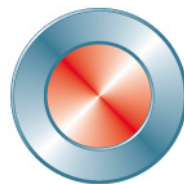

Stafsjö
SINCE 1666

www.stafsjo.com

STAFSJÖ

50005E

Stafsjö Valves AB
SE-618 95 Stavsjö, Sweden

+46 11 39 31 00 | info@stafsjo.se
www.stafsjo.com