

## Straight Through Type Diaphragm Valves

### Codification

S D 0 0 D I 1 0 D 1 0 0 5 0

#### BODY DESIGN

<b>W</b>	Weir
<b>S</b>	Straight Through
<b>F</b>	Full Flow

#### FACE TO FACE/DRILLING

<b>DI10</b>	DIN3202F1 PN10
<b>AS15</b>	BS5156 ASA 150
<b>BS10</b>	BS5156 PN10
<b>SPTH</b>	Threaded BSPP

**0B**

#### BODY/BONNET MATERIAL

<b>C</b>	Cast iron
<b>D</b>	Ductile iron
<b>A</b>	Carbon steel
<b>S</b>	St. steel 316
<b>I</b>	Chr. iron 24%
<b>J</b>	Chr. iron 30%
<b>B</b>	Bronze
<b>K</b>	St. steel 316L
<b>E</b>	St. steel 304
<b>M</b>	Monel
<b>H</b>	Hastelloy
<b>X</b>	St. steel 1.4435
<b>Y</b>	St. steel 1.4435 BN2

#### DIAPHRAGM/SEALING

<b>D10</b>	Natural rubber
<b>D15</b>	White natural rubber
<b>D20</b>	EPDM
<b>D2V</b>	EPDM vacuum service
<b>D30</b>	Butyl
<b>D40</b>	NBR
<b>D4V</b>	NBR vacuum service
<b>D50</b>	Neoprene
<b>D60</b>	Hypalon
<b>D70</b>	Viton
<b>D92</b>	PTFE/EPDM
<b>D93</b>	PTFE/Butyl
<b>D97</b>	PTFE/Viton
<b>DLN</b>	Linatex

#### BODY BASE MATERIAL

<b>00</b>	Unlined
<b>HR</b>	Hard rubber
<b>SR</b>	Soft rubber
<b>BR</b>	Butyl rubber
<b>ER</b>	EPDM rubber
<b>NL</b>	Neoprene rubber
<b>HY</b>	Hypalon® rubber
<b>PF</b>	PFA
<b>FE</b>	FEP
<b>ET</b>	ETFE
<b>HL</b>	Halar®
<b>LN</b>	Linatex

#### SIZE

<b>015</b>	DN15
<b>050</b>	DN50
<b>100</b>	DN100

## Design Attributes

Straight Through Type Diaphragm Valves are linear motion valves, bidirectional, for stopping the flow of the service fluid when necessary, not being suitable for regulation purposes. Valves close by turning the handwheel clockwise. Valves are bolted bonnet, seatless design, with a diaphragm as closure element, with rising handwheel. Valves are offered with a broad range of diaphragms and linings materials to resist to abrasion and corrosion duties. Their straight passage makes them more suitable for on/off applications in comparison to Weir Type, when low pressure drop is required or in case of abrasive media. The valves are inexpensive and easy to maintain, being the optimal solution for a large number of applications.

Yellow position indicator, for clear and positive valve position from any angle

Ergonomic and rugged rising handwheel

Grease reservoir integrated in the spindle chamber that lubricates the spindle along operations thus avoiding valve spindle jamming

Nameplate incl. batch no. for full traceability

Witness hole to detect leakage at diaphragm failure

Precise compressor plate; guides and operates the diaphragm up and down

Closure Diaphragms; manufactured from elastomeric materials; provide 100% seating tightness in both directions while isolating the valve trim from fluid. Wide choice of polymers to satisfy any industrial application

Full rubber flange face in all rubber lined valves as standard

Porousless linings; provides the application engineer with a wide choice of linings of high chemical and abrasion resistance without need of expensive basic metal valve materials

Pocketless design, unobstructed bore

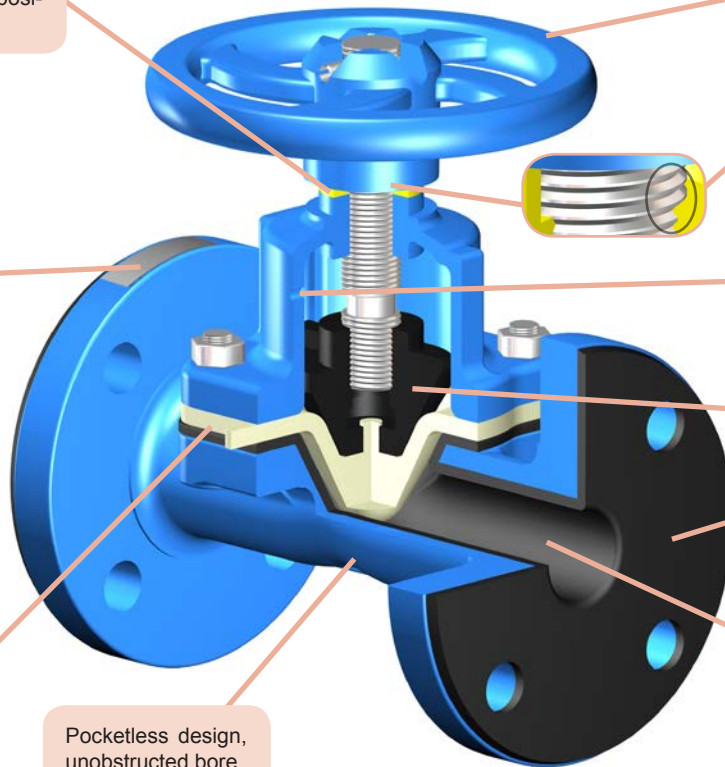

## Main Features

Valve design: EN 13397, EN 12516

Face to face length: EN 558 Series 1 (DIN 3202F1) or EN 558 Series 7 (BS 5156)

Valve end connections: Flanged to EN 1092-2 type 21/B, PN10/16 (DN15-150); PN10 (DN200-300)

(valves DN65 with 4 holes as accepted variant in standard)

option drilling to ASA150#

Female thread to ISO 228-1 (DIN 259-BSPP)

Marking: EN 19

Pressure Tests: EN 12266-1

Seat leakage rate: Rate A (full seat tightness in both directions)

Inside and outside primer paint layer black color for protection during storage and transport

Product compliant with Directive 2014/68/EU on Pressure Equipment (PED) and Machinery Directive 2006/42/EC

## Options

Other materials, other ratings and connections, pneumatic or electric actuator, limit switches, sealed bonnet, interlocking arrangement, padlocking or handwheel hood to avoid non-authorized operation. Please consult us

**Main Duties / Limits of use**

Liquids compatible with materials of construction, acc. to Directive 2014/68/EU, Annex II tables 8 (group 1\*) & 9 (group 2\*) up to category I  
 PS 10 bar DN15-100 (Art.4-Parr.3)  
 PS 6 bar DN125-150 (Art.4-Parr.3)  
 PS 3,5 bar DN200-300 (Art.4-Parr.3)  
 Combination of Body + Lining + Diaphragm determines the P-T limit of use of the valve  
 Questions referring to chemical resistance, please consult us  
 Observe also pressure/temperature limits on diagrams under  
 \*Classification of fluids (group 1 or 2) acc. to Directive 2014/68/EU, Article 13

**Bodies (Ductile iron)**

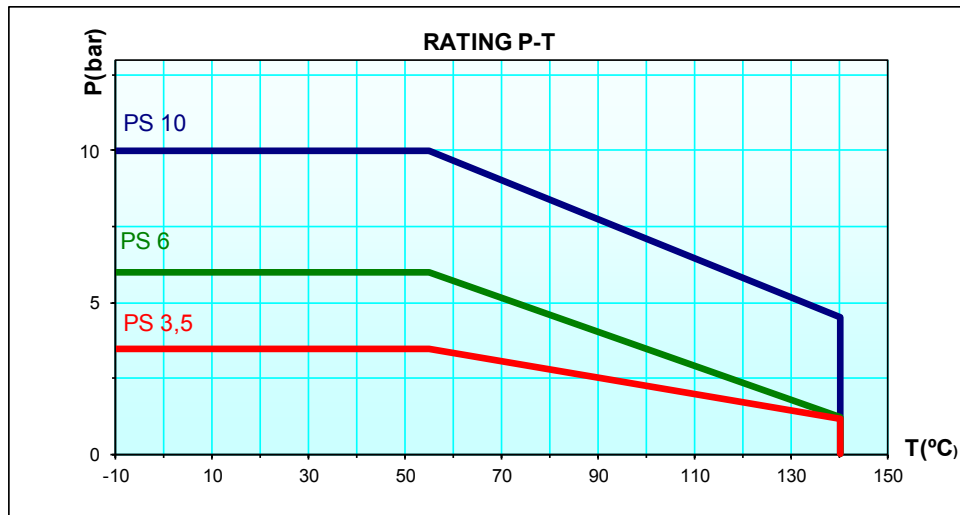

**Linings**

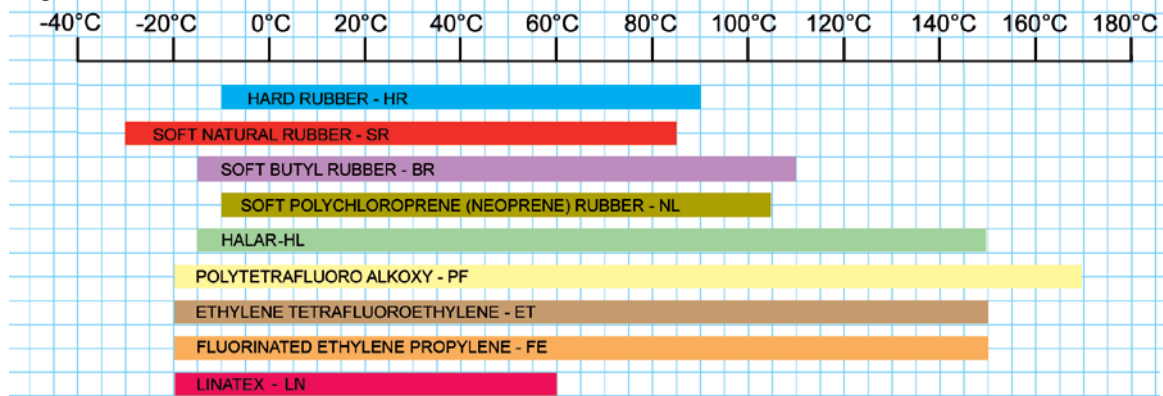

**Diaphragms**

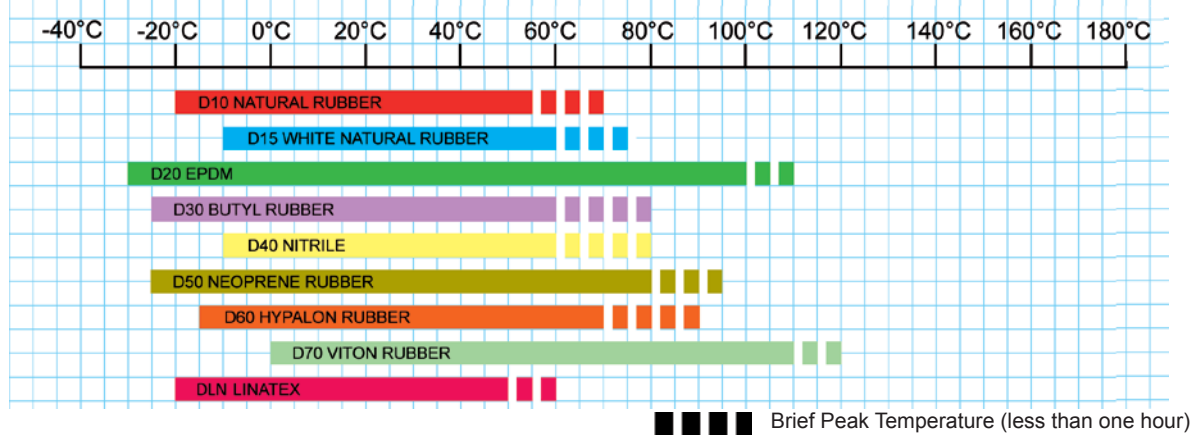

Temperature values are for neutral fluids and not plotted against any pressure parameter, the application engineer should consider that working limits are affected by the actual pressure / temperature relationship. Temperature values also depends on medium through the valve.

## Valves Flow Data

A valve flow coefficient represents the standard flow rate which flows through the valve at a given opening, referred to pre-established conditions:

\* Kv value is the volume of water at 20°C, in cubic meters per hour (m<sup>3</sup>/h), that will flow through the valve at a static pressure drop of 1 bar across the valve

\* Cv value is the volume of water at 60°F, in gallons per minute (gpm), that will flow through the valve at a static pressure drop of 1 psi across the valve

Conversion from Kv to Cv can be roughly calculated by means of the following expression:

$$Cv = Kv \times 1,17$$

Flow rate through the valve with other liquids can be calculated with the following expressions

$$Kv = q (SG / dp)^{1/2}$$

where

q = water flow (cubic meter per hour)

SG = specific gravity (1 for water)

dp = pressure drop (bar)

$$Cv = q (SG / dp)^{1/2}$$

where

q = water flow (US gallons per minute)

SG = specific gravity (1 for water)

dp = pressure drop (psi)

## Straight Through Kv (m<sup>3</sup>/h) values with valve fully open \*

DN mm	Ductile iron	Rubber Lined	Halar® Lined
15	7,5	5,5	7,6
20	18	13,5	18,5
25	32	26	33
32	47	39	48
40	64	56	67
50	110	90	116
65	204	165	214
80	293	222	302
100	504	406	524
125	792	618	813
150	1440	1105	1510
200	2211	1895	2290
250	3446	2960	3596
300	5168	4250	5314

\*Since Straight Through Diaphragm Valves are only suitable for on/off service we only provide Kv values for valves fully open.

Unlined valves with flanged ends

Main Parts and Materials

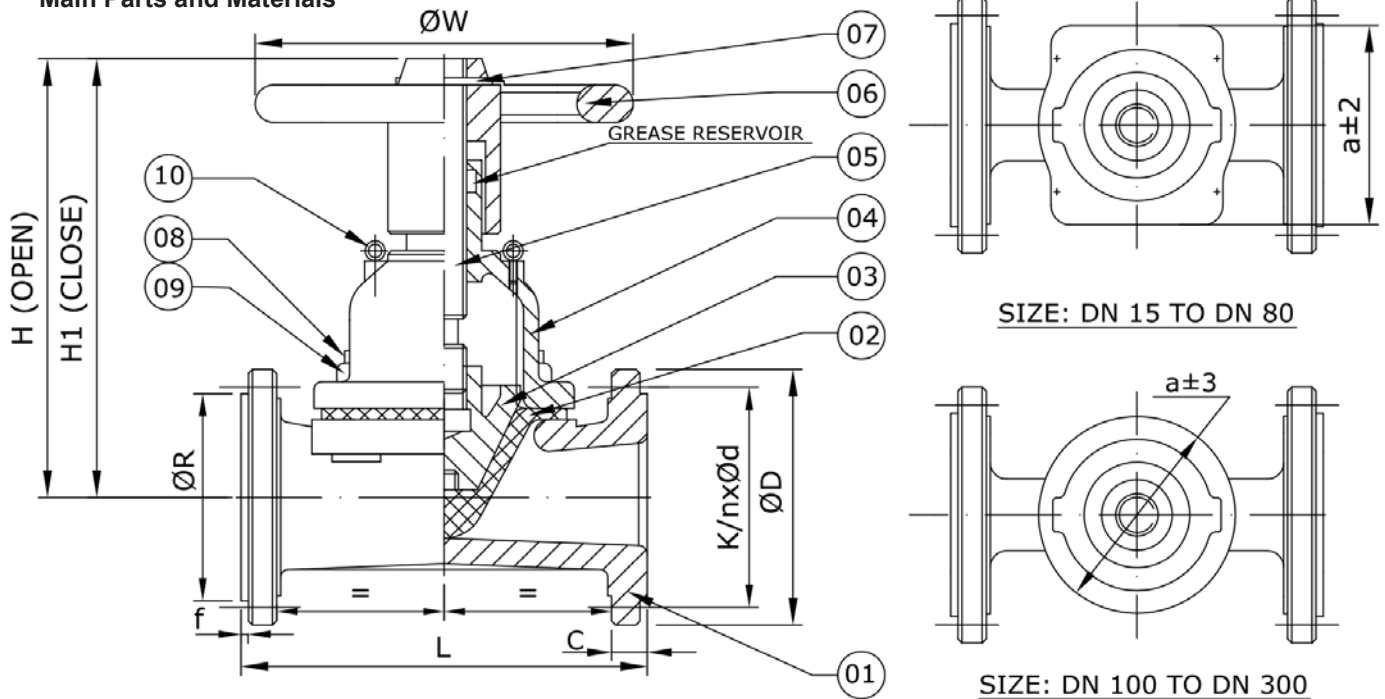

NO.	PART	MATERIAL
1	BODY	SC_ Cast iron EN-JL1040 (GG25)
		SD_ Ductile iron EN-JS1030 (GGG40)
2	DIAPHRAGM	Rubber Natural (D10) / EPDM (D20) / Butyl (D30) / Nitrile (D40) / Neoprene (D50) / Hypalon (D60) / Viton (D70)
3	COMPRESSOR	Cast iron EN-JL1040 (GG25)
4	BONNET	SC_ Cast iron EN-JL1040 (GG25)
		SD_ Ductile iron EN-JS1030 (GGG40)

NO.	PART	MATERIAL
5	SPINDLE	Steel
6	HANDWHEEL	Cast iron EN-JL1040 (GG25)
7	H/W DOWEL PIN	Steel (EN42)
8	BODY STUDS	Steel
9	BODY NUTS	Steel
10	EYE BOLT*	Steel

\* Only for some sizes

Main Valve Parameters

	DN	15	20	25	32	40	50	65
L	EN 558 S7 (BS 5156)	108	114	127	146	159	190	216
	EN 558 S1 (DIN 3202 F1)	130	150	160	180	200	230	290
	H (open)	110	108	132,5	130,5	131,5	194,5	220
	H1 (close)	102	100	120	118	119	177	196
	a	71	71	85	85	85	115	130
	ØW	100	100	120	120	120	164	220
FLANGED ENDS TO EN PN10	ØD	95	105	115	140	150	165	185
	C	14	16	16	18	18	20	20
	ØR	45	58	68	78	88	102	122
	f	2	2	2	2	3	3	3
	nxØd	4x14	4x14	4x14	4x18	4x18	4x18	4x18
FLANGED ENDS TO ASA150#*	ØK	65	75	85	100	110	125	145
	ØD	89	98	108	117	127	152	178
	C	11,5	11,5	11,5	13	14,5	16	17,5
	ØR	35	43	51	64	73	92	105
	f	1,6	1,6	1,6	1,6	1,6	1,6	1,6
Approx. Weight	EN 558 S7 (BS 5156)	3,3	3,6	4,3	6,5	7	10,5	15,5
	EN 558 S1 (DIN 3202 F1)	3,8	4	4,8	7,5	8	11,5	16,5

\*Unless specific agreement with COMEVAL, valves with flanges 150# will be usually supplied as EN/DIN flanges with 150# drilling, since pressure is limited to EN/DIN

Dimensions in mm subject to manufacturing tolerance / Weights in kg

Information / restriction of technical rules need to be observed!  
Installation, Operating and Maintenance Manual can be downloaded at [www.comeval.es](http://www.comeval.es)

The engineer, designing a system or a plant, is responsible for the selection of the correct valve  
Product suitability must be verified, contact manufacturer for information

## Unlined valves with flanged ends

## Main Valve Parameters

	DN	80	100	125	150	200	250	300
L	EN 558 S7 (BS 5156)	254	305	356	406	521	635	749
	EN 558 S1 (DIN 3202 F1)	310	350	400	480	600	730	850
	H (open)	279	293	310	413	475,5	595,5	748
	H1 (close)	249	261	272	362	413	523	653
	a	171	Ø200	Ø234	Ø290	Ø350	Ø430	Ø512
	ØW	240	270	270	360	460	525	600
FLANGED ENDS TO EN PN10	ØD	200	220	250	285	340	395	445
	C	22	24	26	26	26	28	28
	ØR	138	158	188	212	268	320	370
	f	3	3	3	3	3	3	4
	nxØd	8x18	8x18	8x18	8x22	8x22	12x22	12x22
FLANGED ENDS TO ASA150#	ØK	160	180	210	240	295	350	400
	ØD	191	229	254	279	343	406	483
	C	19,5	24	24	25,5	29	30,5	32
	ØR	127	157	186	216	270	324	381
	f	1,6	1,6	1,6	1,6	1,6	1,6	1,6
Approx. Weight	EN 558 S7 (BS 5156)	22,5	30	44	63	112	170	258
	EN 558 S1 (DIN 3202 F1)	25,5	32	46	69	126	185	273

\*Unless specific agreement with COMEVAL, valves with flanges 150# will be usually supplied as EN/DIN flanges with 150# drilling, since pressure is limited to EN/DIN

Dimensions in mm subject to manufacturing tolerance / Weights in kg

## Rubber lined valves with flanged ends

### Main Parts and Materials

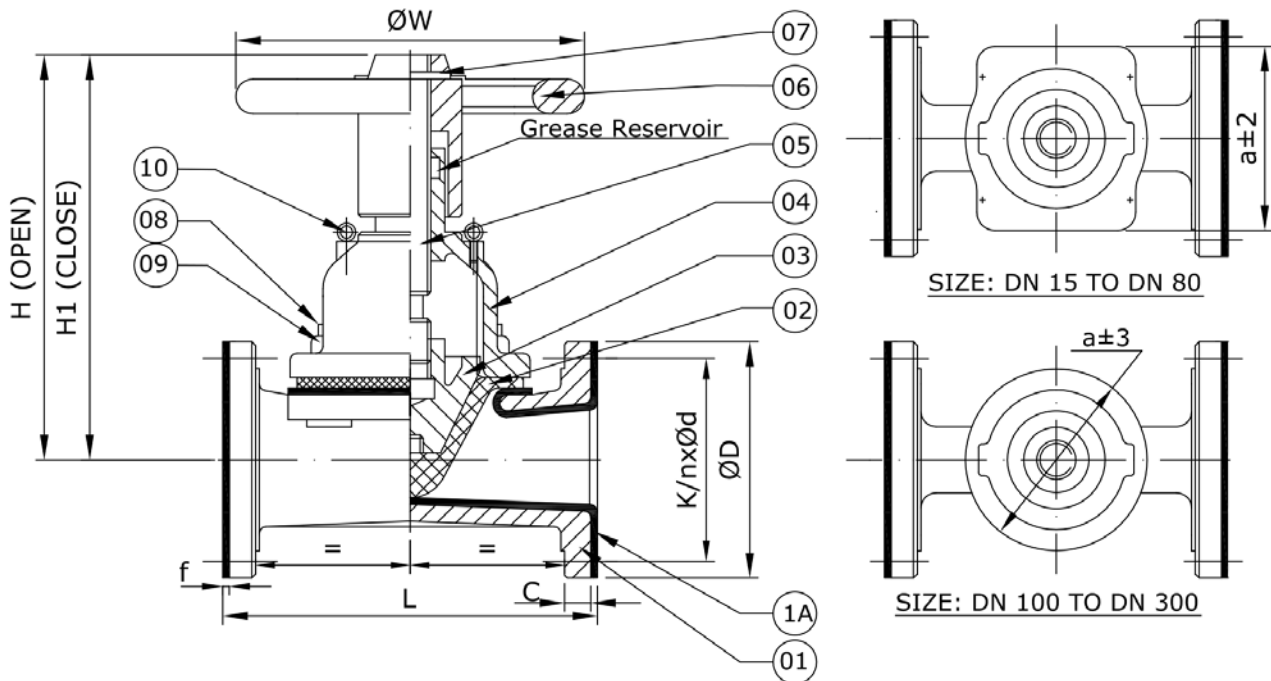

NO.	PART	MATERIAL
1	BODY	SC_ Cast iron EN-JL1040 (GG25)
		SD_ Ductile iron EN-JS1030 (GGG40)
1A	LINING	_HR_ Hard rubber
		_SR_ Soft rubber
		_BR_ Butyl rubber
		_ER_ EPDM rubber
		_NL_ Neoprene rubber
2	DIAPHRAGM	Rubber Natural (D10) / EPDM (D20) / Butyl (D30) / Nitrile (D40) / Neoprene (D50) / Hypalon (D60) / Viton (D70)

NO.	PART	MATERIAL
3	COMPRESSOR	Cast iron EN-JL1040 (GG25)
4	BONNET	SC_ Cast iron EN-JL1040 (GG25)
		SD_ Ductile iron EN-JS1030 (GGG40)
5	SPINDLE	Steel
6	HANDWHEEL	Cast iron EN-JL1040 (GG25)
7	H/W DOWEL PIN	Steel (EN42)
8	BODY STUDS	Steel
9	BODY NUTS	Steel
10	EYE BOLT*	Steel

\* Only for some sizes

### Main Valve Parameters

	DN	15	20	25	32	40	50	65
L	EN 558 S7 (BS 5156)	114	123	133	152	165	196	222
	EN 558 S1 (DIN 3202 F1)	130	150	160	180	200	230	290
	H (open)	113	111	135,5	133,5	134,5	197,5	223
	H1 (close)	105	103	123	121	122	180	199
	f	3	3	3	3	3	3	3
	a	71	71	85	85	85	115	130
FLANGED ENDS TO EN PN10	ØW	100	100	120	120	120	164	220
	ØD	95	105	115	140	150	165	185
	C	14	16	16	18	18	20	20
	nxØd	4x14	4x14	4x14	4x18	4x18	4x18	4x18
	ØK	65	75	85	100	110	125	145
FLANGED ENDS TO ASA150#*	ØD	89	98	108	117	127	152	178
	C	11,5	11,5	11,5	13,0	14,5	16,0	17,5
	nxØd	4x16	4x16	4x16	4x16	4x16	4x19	4x19
	ØK	60,3	69,8	79,4	88,9	98,4	120,6	139,7
Approx. Weight	EN 558 S7 (BS 5156)	3,6	4	4,5	7	8	12	17
	EN 558 S1 (DIN 3202 F1)	4,1	4,5	5,0	8	9	13,5	18

\*Unless specific agreement with COMEVAL, valves with flanges 150# will be usually supplied as EN/DIN flanges with 150# drilling, since pressure is limited to EN/DIN

Dimensions in mm subject to manufacturing tolerance / Weights in kg

Information / restriction of technical rules need to be observed!  
Installation, Operating and Maintenance Manual can be downloaded at [www.comeval.es](http://www.comeval.es)

The engineer, designing a system or a plant, is responsible for the selection of the correct valve  
Product suitability must be verified, contact manufacturer for information

**Rubber lined valves with flanged ends**

**Main Valve Parameters**

DN		80	100	125	150	200	250	300
<b>L</b>	<b>EN 558 S7 (BS 5156)</b>	260	313	364	414	529	643	757
	<b>EN 558 S1 (DIN 3202 F1)</b>	310	350	400	480	600	730	850
	<b>H (open)</b>	282	297,5	313,5	417	479,5	598,5	752
	<b>H1 (close)</b>	252	265	276	366	417	527	657
	<b>f</b>	3	4	4	4	4	4	4
	<b>a</b>	171	Ø200	Ø234	Ø290	Ø350	Ø430	Ø512
	<b>ØW</b>	240	270	270	360	460	525	600
<b>FLANGED ENDS TO EN PN10</b>	<b>ØD</b>	200	220	250	285	340	395	445
	<b>C</b>	22	24	26	26	26	28	28
	<b>nxØd</b>	8x18	8x18	8x18	8x22	8x22	12x22	12x22
	<b>ØK</b>	160	180	210	240	295	350	400
<b>FLANGED ENDS TO ASA150#*</b>	<b>ØD</b>	191	229	254	279	343	406	483
	<b>C</b>	19,5	24,0	24,0	25,5	29,0	30,5	32,0
	<b>nxØd</b>	4x19	8x19	8x22	8x22	8x22	12x26	12x26
	<b>ØK</b>	152,4	190,5	215,9	241,3	298,4	361,9	431,8
<b>Approx. Weight</b>	<b>EN 558 S7 (BS 5156)</b>	24	32	46	65	115	175	263
	<b>EN 558 S1 (DIN 3202 F1)</b>	27	34	48	71	121	190	278

\*Unless specific agreement with COMEVAL, valves with flanges 150# will be usually supplied as EN/DIN flanges with 150# drilling, since pressure is limited to EN/DIN

Dimensions in mm subject to manufacturing tolerance / Weights in kg



## Fluoropolymer lined valves with flanged ends

### Main Parts and Materials

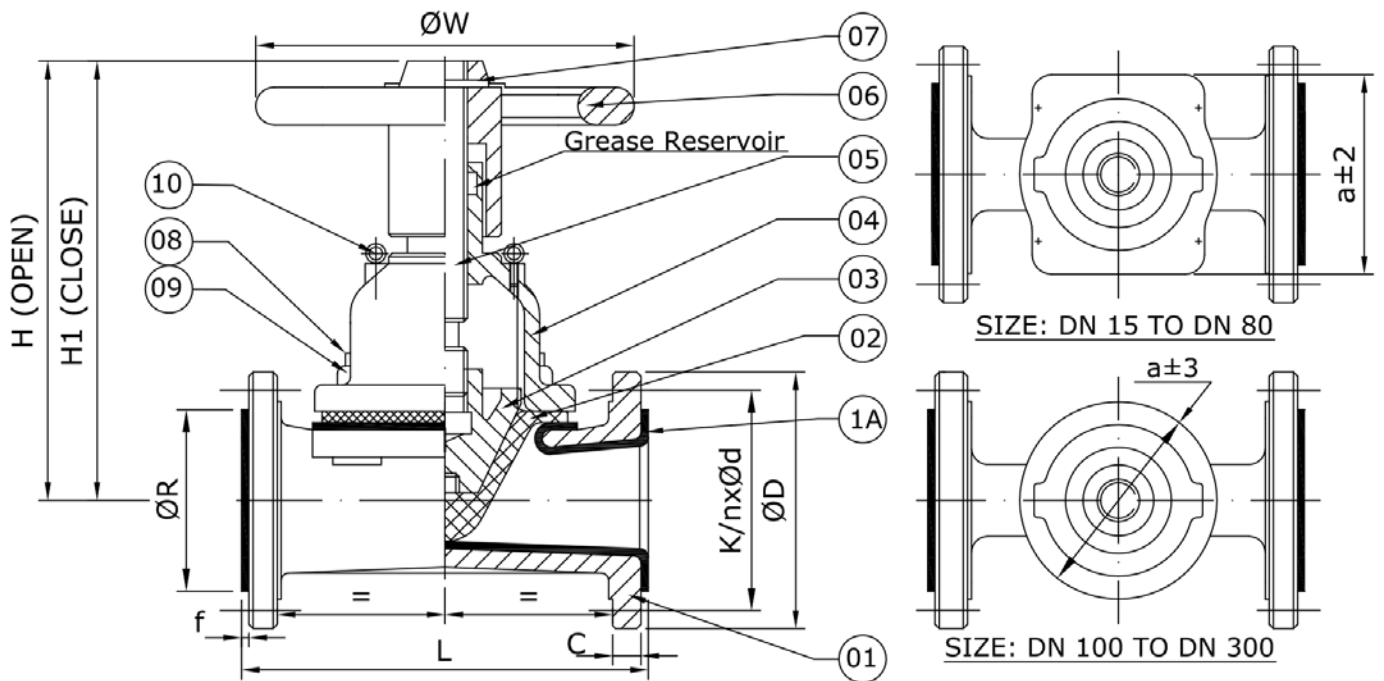

NO.	PART	MATERIAL
1	BODY	Ductile iron EN-JS1030 (GGG40)
1A	LINING	_PF_ PFA
		_FE_ FEP
		_ET_ ETFE
2	DIAPHRAGM	Rubber Natural (D10) / EPDM (D20) / Butyl (D30) / Nitrile (D40) / Neoprene (D50) / Hypalon (D60) / Viton (D70)
3	COMPRESSOR	Cast iron EN-JL1040 (GG25)

NO.	PART	MATERIAL
4	BONNET	Ductile iron EN-JS1030 (GGG40)
5	SPINDLE	Steel
6	HANDWHEEL	Cast iron EN-JL1040 (GG25)
7	H/W DOWEL PIN	Steel (EN42)
8	BODY STUDS	St. steel SS304
9	BODY NUTS	St. steel SS304
10	EYE BOLT*	Steel

\* Only for some sizes

### Main Valve Parameters

	DN	15	20	25	32	40	50	65
L	EN 558 S7 (BS 5156)	114	123	133	152	165	196	222
	EN 558 S1 (DIN 3202 F1)	130	150	160	180	200	230	290
	H (open)	113	111	135,5	133,5	134,5	197,5	223
	H1 (close)	105	103	123	121	122	180	199
	f*	3	3	3	3	3	3	3
	a	71	71	85	85	85	115	130
	ØW	100	100	120	120	120	164	220
FLANGED ENDS TO EN PN10	ØD	95	105	115	140	150	165	185
	C	14	16	16	18	18	20	20
	nxØd	4x14	4x14	4x14	4x18	4x18	4x18	4x18
	ØK	65	75	85	100	110	125	145
FLANGED ENDS TO ASA150#**	ØD	89	98	108	117	127	152	178
	C	11,5	11,5	11,5	13,0	14,5	16,0	17,5
	nxØd	4x16	4x16	4x16	4x16	4x16	4x19	4x19
	ØK	60,3	69,8	79,4	88,9	98,4	120,6	139,7
Approx. Weight	EN 558 S7 (BS 5156)	3,6	4	4,5	7	8	12	17
	EN 558 S1 (DIN 3202 F1)	4,1	4,5	5	8	9	13,5	18

\* Consult f for PFA

\*\*Unless specific agreement with COMEVAL, valves with flanges 150# will be usually supplied as EN/DIN flanges with 150# drilling, since pressure is limited to EN/DIN

Dimensions in mm subject to manufacturing tolerance / Weights in kg

Information / restriction of technical rules need to be observed!  
Installation, Operating and Maintenance Manual can be downloaded at [www.comeval.es](http://www.comeval.es)

The engineer, designing a system or a plant, is responsible for the selection of the correct valve  
Product suitability must be verified, contact manufacturer for information

## Fluoropolymer lined valves with flanged ends

### Main Valve Parameters

DN		80	100	125	150	200	250	300
L	EN 558 S7 (BS 5156)	260	313	364	414	529	643	757
	EN 558 S1 (DIN 3202 F1)	310	350	400	480	600	730	850
	H (open)	282	297,5	313,5	417	479,5	598,5	752
	H1 (close)	252	265	276	366	417	527	657
f*		3	4	4	4	4	4	4
a		171	Ø200	Ø234	Ø290	Ø350	Ø430	Ø512
ØW		240	270	270	360	460	525	600
FLANGED ENDS TO EN PN10	ØD	200	220	250	285	340	395	445
	C	22	24	26	26	26	28	28
	nxØd	8x18	8x18	8x18	8x22	8x22	12x22	12x22
	ØK	160	180	210	240	295	350	400
FLANGED ENDS TO ASA150#**	ØD	191	229	254	279	343	406	483
	C	19,5	24,0	24,0	25,5	29,0	30,5	32,0
	nxØd	4x19	8x19	8x22	8x22	8x22	12x26	12x26
	ØK	152,4	190,5	215,9	241,3	298,4	361,9	431,8
Approx. Weight	EN 558 S7 (BS 5156)	24	32	46	65	115	175	263
	EN 558 S1 (DIN 3202 F1)	27	34	48	71	121	190	278

\* Consult f for PFA

\*\* Unless specific agreement with COMEVAL, valves with flanges 150# will be usually supplied as EN/DIN flanges with 150# drilling, since pressure is limited to EN/DIN

Dimensions in mm subject to manufacturing tolerance / Weights in kg

**Halar® coated valves with flanged ends**

**Main Parts and Materials**

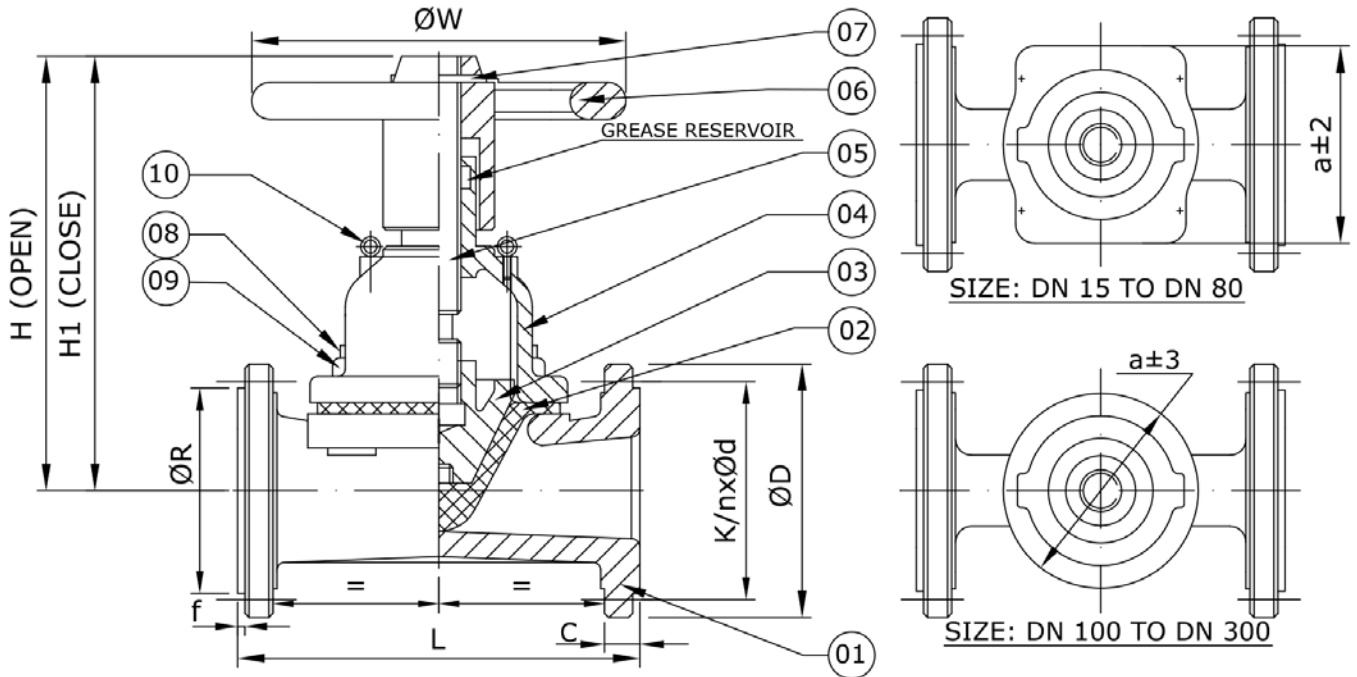

NO.	PART	MATERIAL
1	BODY	SCHL_ Cast iron EN-JL1040 (GG25)
		SDHL_ Ductile iron EN-JS1030 (GGG40)
2	DIAPHRAGM	Natural (D10) / EPDM (D20) / Butyl (D30) /
		Nitrile (D40) / Neoprene (D50) / Hypalon (D60) /
		Viton (D70)
		Rubber
3	COMPRESSOR	Cast iron EN-JL1040 (GG25)
4	BONNET	SCHL_ Cast iron EN-JL1040 (GG25)
		SDHL_ Ductile iron EN-JS1030 (GGG40)

NO.	PART	MATERIAL
5	SPINDLE	Steel
6	HANDWHEEL	Cast iron EN-JL1040 (GG25)
7	H/W DOWEL PIN	Steel (EN42)
8	BODY STUDS	St. steel SS304
9	BODY NUTS	St. steel SS304
10	EYE BOLT*	Steel

\* Only for some sizes

**Main Valve Parameters**

	DN	15	20	25	32	40	50	65
L	EN 558 S7 (BS 5156)	108	114	127	146	159	190	216
	EN 558 S1 (DIN 3202 F1)	130	150	160	180	200	230	290
	H (open)	110	108	132,5	130,5	131,5	194,5	220
	H1 (close)	102	100	120	118	119	177	196
	a	71	71	85	85	85	115	130
	ØW	100	100	120	120	120	164	220
FLANGED ENDS TO EN PN10	ØD	95	105	115	140	150	165	185
	C	14	16	16	18	18	20	20
	ØR	45	58	68	78	88	102	122
	f	2	2	2	2	3	3	3
	nxØd	4x14	4x14	4x14	4x18	4x18	4x18	4x18
	ØK	65	75	85	100	110	125	145
FLANGED ENDS TO ASA150#	ØD	89	98	108	117	127	152	178
	C	11,5	11,5	11,5	13,0	14,5	16,0	17,5
	ØR	35	43	51	64	73	92	105
	f	1,6	1,6	1,6	1,6	1,6	1,6	1,6
	nxØd	4x16	4x16	4x16	4x16	4x16	4x19	4x19
	ØK	60,3	69,8	79,4	88,9	98,4	120,6	139,7
Approx. Weight	EN 558 S7 (BS 5156)	3,3	3,6	4,3	6,5	7	10,5	15,5
	EN 558 S1 (DIN 3202 F1)	3,8	4	4,8	7,5	8	11,5	16,5

\*Unless specific agreement with COMEVAL, valves with flanges 150# will be usually supplied as EN/DIN flanges with 150# drilling, since pressure is limited to EN/DIN

Dimensions in mm subject to manufacturing tolerance / Weights in kg

Information / restriction of technical rules need to be observed!  
Installation, Operating and Maintenance Manual can be downloaded at [www.comeval.es](http://www.comeval.es)

The engineer, designing a system or a plant, is responsible for the selection of the correct valve  
Product suitability must be verified, contact manufacturer for information

**Halar® coated valves with flanged ends**

**Main Valve Parameters**

DN		80	100	125	150	200	250	300
<b>L</b>	<b>EN 558 S7 (BS 5156)</b>	254	305	356	406	521	635	749
	<b>EN 558 S1 (DIN 3202 F1)</b>	310	350	400	480	600	730	850
	<b>H (open)</b>	279	293	309,5	413	475,5	595,5	748
	<b>H1 (close)</b>	249	261	272	362	413	523	653
	<b>a</b>	171	Ø200	Ø234	Ø290	Ø350	Ø430	Ø512
	<b>ØW</b>	240	270	270	360	460	525	600
<b>FLANGED ENDS TO EN PN10</b>	<b>ØD</b>	200	220	250	285	340	395	445
	<b>C</b>	22	24	26	26	26	28	28
	<b>ØR</b>	138	158	188	212	268	320	370
	<b>f</b>	3	3	3	3	3	3	4
	<b>nxØd</b>	8x18	8x18	8x18	8x22	8x22	12x22	12x22
<b>FLANGED ENDS TO ASA150#*</b>	<b>ØK</b>	160	180	210	240	295	350	400
	<b>ØD</b>	191	229	254	279	343	406	483
	<b>C</b>	19,5	24,0	24,0	25,5	29,0	30,5	32,0
	<b>ØR</b>	127	157	186	216	270	324	381
	<b>f</b>	1,6	1,6	1,6	1,6	1,6	1,6	1,6
	<b>nxØd</b>	4x19	8x19	8x22	8x22	8x22	12x26	12x26
	<b>ØK</b>	152,4	190,5	215,9	241,3	298,4	361,9	431,8
<b>Approx. Weight</b>	<b>EN 558 S7 (BS 5156)</b>	22,5	30	44	63	112	170	258
	<b>EN 558 S1 (DIN 3202 F1)</b>	25,5	32	46	69	126	185	273

\*Unless specific agreement with COMEVAL, valves with flanges 150# will be usually supplied as EN/DIN flanges with 150# drilling, since pressure is limited to EN/DIN

Dimensions in mm subject to manufacturing tolerance / Weights in kg

**Unlined threaded valves**

**Main Parts and Materials**

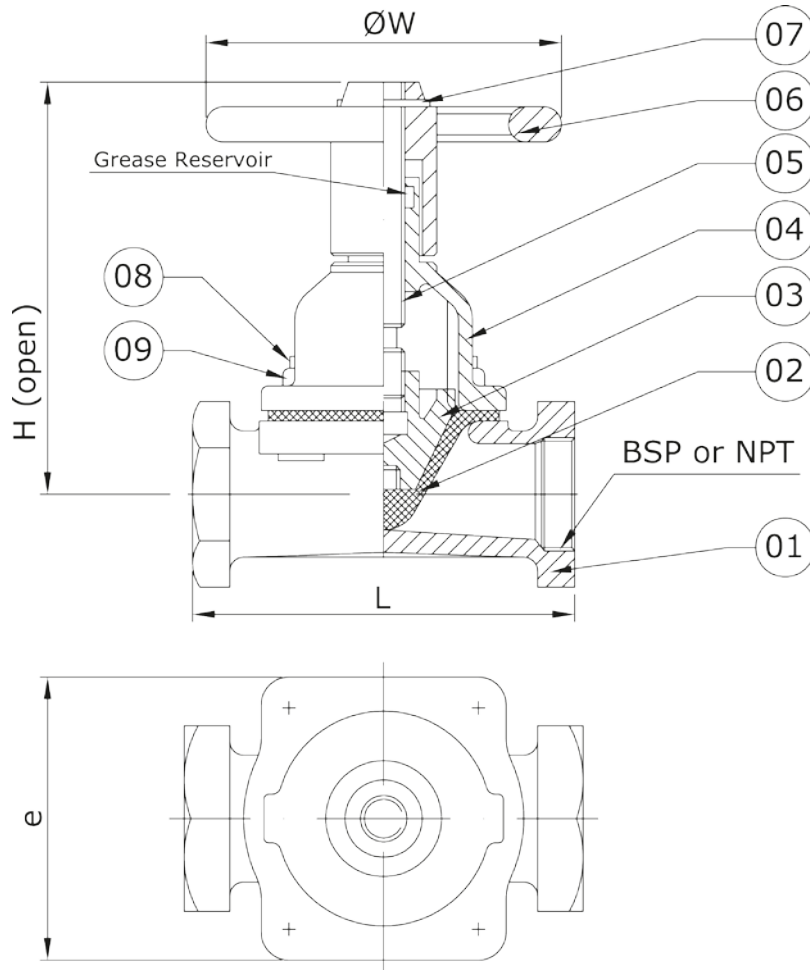

NO.	PART	MATERIAL
1	BODY	SC_ Cast iron EN-JL1040 (GG25)
		SD_ Ductile iron EN-JS1030 (GGG40)
2	DIAPHRAGM	Rubber Natural (D10) / EPDM (D20) / Butyl (D30) / Nitrile (D40) / Neoprene (D50) / Hypalon (D60) / Viton (D70)
3	COMPRESSOR	Cast iron EN-JL1040 (GG25)
4	BONNET	SC_ Cast iron EN-JL1040 (GG25)
		SD_ Ductile iron EN-JS1030 (GGG40)
5	SPINDLE	Steel
6	HANDWHEEL	Cast iron EN-JL1040 (GG25)
7	H/W DOWEL PIN	Steel (EN42)
8	BODY STUDS	Steel
9	BODY NUTS	Steel

**Main Valve Parameters**

DN	15	20	25	32	40	50	65	80
L	64	83	108	121	140	165	203	254
H (open)	112	117	142	142	140	206	236	284
ØW	100	100	120	120	120	164	220	240
e	71	71	85	85	85	115	130	171
Approx. Weight	1,8	2,2	3	4	4	7,25	12,5	19,5

Dimensions in mm subject to manufacturing tolerance / Weights in kg

Main Bonnet Dimensions

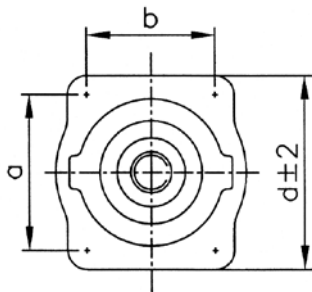
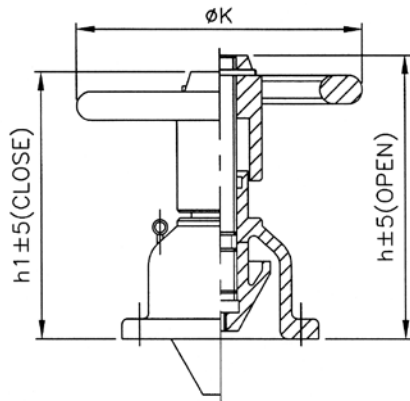

SIZE: DN 15 TO DN 80

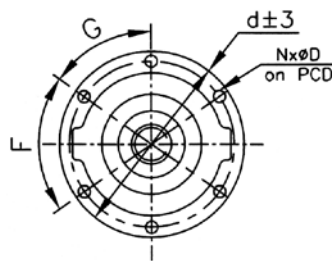

SIZE: DN 100

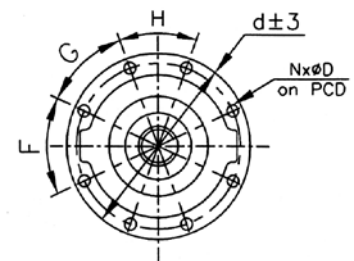

SIZE: DN 125 TO DN 200

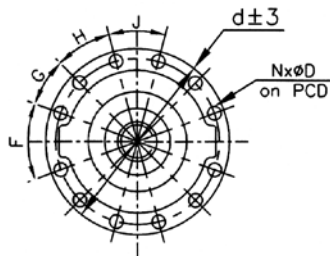

SIZE: DN 250

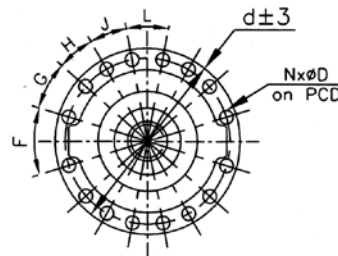

SIZE: DN 300

DN	a	b ØPCD	d	h	h1	ØK	NxØD	Weight	ANGLES BETWEEN THE HOLES				
									F	G	H	J	L
15	54	30	71	93,5	86,0	100	4x7	1,2	---	---	---	---	---
20	54	30	71	93,5	86,0	100	4x7	1,2	---	---	---	---	---
25	64	51	85	105,0	93,0	120	4x9	2,0	---	---	---	---	---
32	64	51	85	105,0	93,0	120	4x9	2,0	---	---	---	---	---
40	64	51	85	105,0	93,0	120	4x9	2,0	---	---	---	---	---
50	89	64	115	165,0	147,5	164	4x11	4,5	---	---	---	---	---
65	102	83	130	185,0	161,0	220	4x13	7,0	---	---	---	---	---
80	137	102	171	231,0	201,0	240	4x17	11,0	---	---	---	---	---
100	---	Ø171	Ø200	243,0	210,5	270	6x13	14,5	70°	55°	---	---	---
125	---	Ø205	Ø234	264,0	226,5	270	8x13	18,0	50°	45°	40°	---	---
150	---	Ø254	Ø290	346,0	295,0	360	8x13	31,0	60°	40°	40°	---	---
200	---	Ø305	Ø350	395,0	333,0	460	8x17	50,0	60°	40°	40°	---	---
250	---	Ø381	Ø430	507,0	434,5	525	12x21	79,0	40°	25°	30°	30°	---
300	---	Ø451	Ø512	641,0	546,0	600	16x21	115,0	34°	24°20'	19°	19°	21°20'

Dimensions in mm subject to manufacturing tolerance / Weights in kg

Main Spare Diaphragms Dimensions

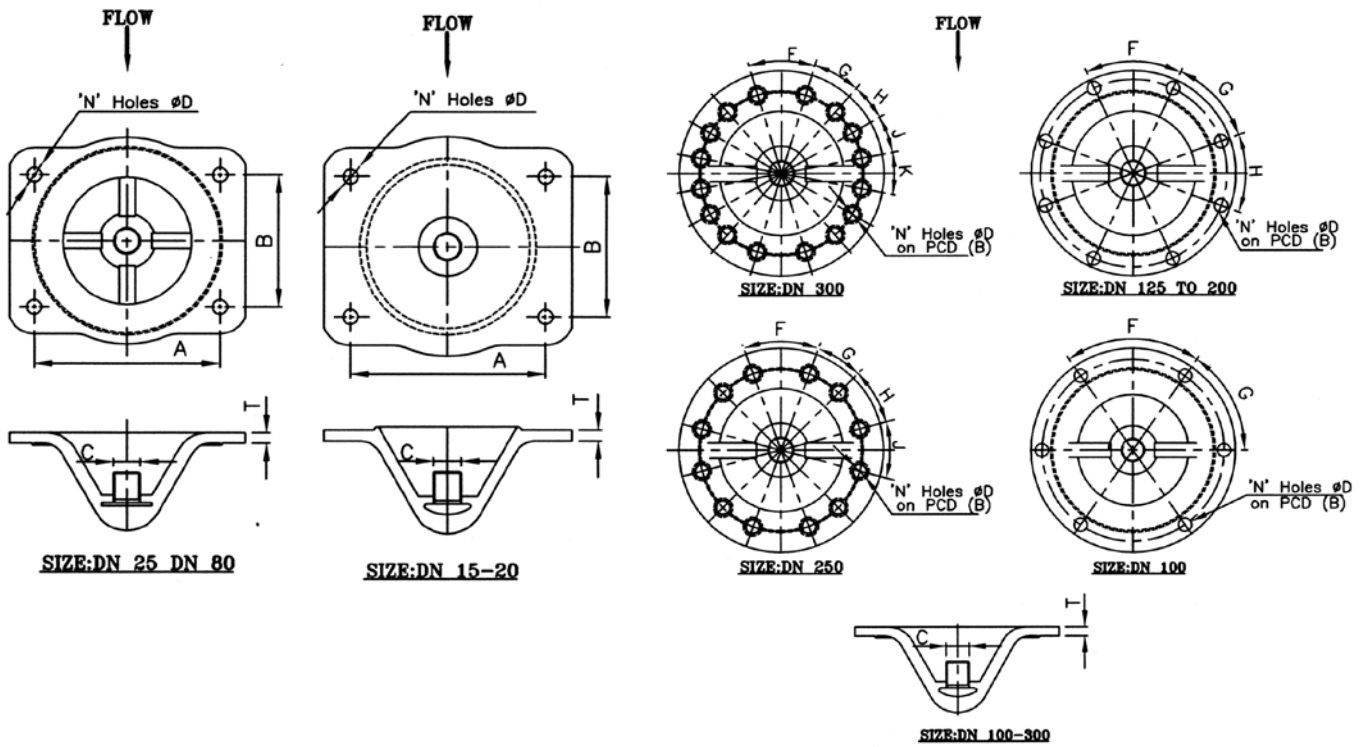

DN	DIMENSIONS OF DIAPHRAGM					ANGLES BETWEEN THE HOLES					
	A	B	C	ØD	N° HOLES	T	F	G	H	J	K
15	54	30	3/16" BSW	7.0	4	2.5	---	---	---	---	---
20	54	30	3/16" BSW	7.0	4	2.5	---	---	---	---	---
25	64	51	1/4" BSW	9.5	4	6.0	---	---	---	---	---
32	64	51	1/4" BSW	9.5	4	6.0	---	---	---	---	---
40	64	51	1/4" BSW	9.5	4	6.0	---	---	---	---	---
50	89	64	1/4" BSW	12.0	4	5.0	---	---	---	---	---
65	102	83	5/16" BSW	14.0	4	5.5	---	---	---	---	---
80	137	102	3/8" BSW	18.0	4	5.5	---	---	---	---	---
100	---	Ø171	3/8" BSW	13.0	6	7.0	70°	55°	---	---	---
125	---	Ø205	3/8" BSW	14.0	8	7.5	50°	45°	40°	---	---
150	---	Ø254	5/8" BSW	14.0	8	8.0	60°	40°	40°	---	---
200	---	Ø305	5/8" BSW	20.0	8	8.5	60°	40°	40°	---	---
250	---	Ø381	5/8" BSW	20.0	12	10.0	40°	25°	30°	30°	---
300	---	Ø451	1" BSW	20.0	16	10.0	34°	24°20'	19°	19°	21°20'

Dimensions in mm subject to manufacturing tolerance / Weights in kg



Brief Guide of Instructions: Replacing an old diaphragm

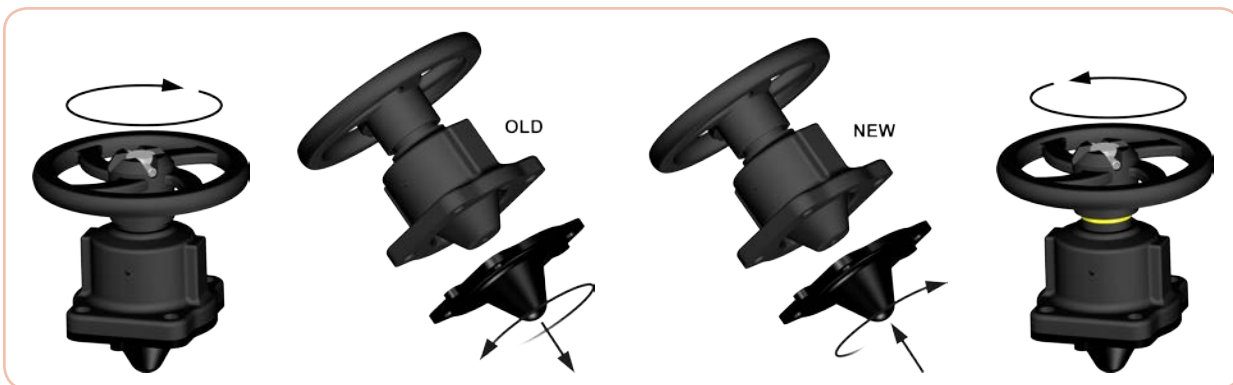



## Straight Through Type Diaphragm Valves with Pneumatic Actuator

### Main Features

- For DIAVAL manufactured valves in weir and straight through type, with rubber diaphragms and PTFE / rubber backed diaphragms.
- Rugged & compact design, long life span at the plant. Favourable size / performance ratio.
- Rolling diaphragm design, allowing long cycle operations.
- Single acting (Direct and reverse actions).
- High quality spring, large thrust.
- Visual position indicator for open / close.
- Burnished stem protected by bellow.
- Maintenance-free O-ring sealing with flexible guiding.
- Possibility of assembly of additional devices / accessories.
- Operating ambient temperatures -40°C to +100°C.
- Fully traceable at the manufacture facility, identified by aluminum riveted plates.
- Optional top mounted emergency hand wheels for manual operation.
- Compliant with Machinery Directive 2006/42/EC

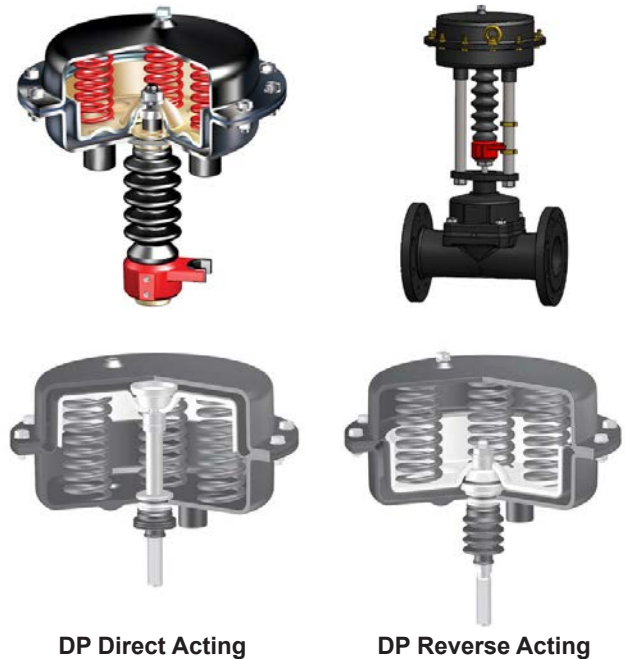

DP Direct Acting

DP Reverse Acting

### Working Principle

Direct Acting actuator is designed to operate from a normally open position. Air pressure on the top side of actuator diaphragm closes the valve and the spring opens the valve when the air is released from the actuator.

Reverse Acting actuator is designed to operate from a normally closed position. Air pressure on the bottom side of the actuator diaphragm opens the valve. When air is released spring closes the valve.

### Control Accesories

There is a number of control accessories available to be assembled on to the ARI actuators. These accessories are comprehensive of limit switches (mechanical or inductive type), proximity sensors, solenoid valves, air speed regulators, positioners, air gauge sets... and many other customized solutions.

Control accessories may be specified and provided by the customer or by DIAVAL, however, only those accessories installed and tested at any DIAVAL facilities are covered by a performance guarantee.

### Tests - After Market

All actuators are tested after assembly and before dispatch. Tests are comprehensive of visual and functional tests as per EN-12266-1/DIN 3230 P.3 - EN.10.204/2.2

Actuators can be serviced at DIAVAL facilities where a stock of common spares is permanently available. Off site service engineers are available on demand and against usual service rates.

### Operating and Maintenance Instructions

Please ensure that the DIAVAL Operating and Maintenance Instructions are provided by your supplier along with the valves. Do not try to start maintenance without having read and understood the Essential Safety Guidelines. Please consult us for further information.

### Standard Materials

Only the best quality materials are incorporated to the DIAVAL manufacturing process and are subject to a strict quality control by our DIAVAL engineers at the assembly plant.

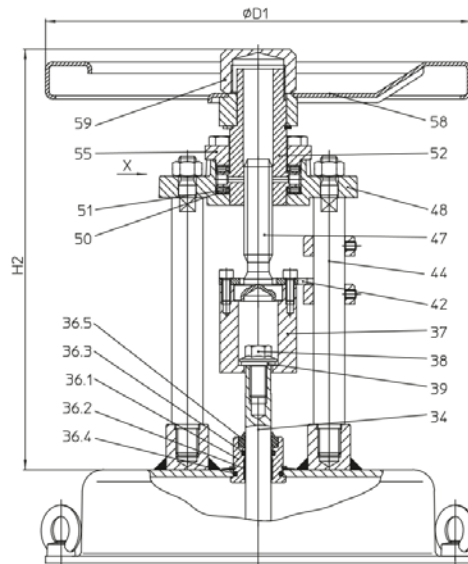
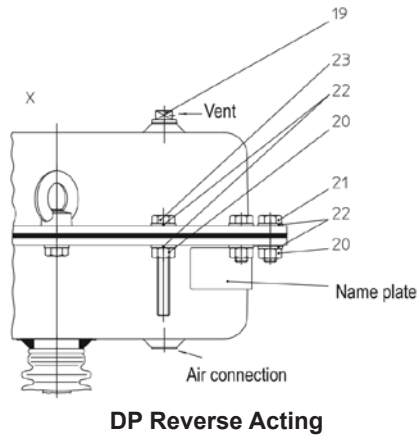
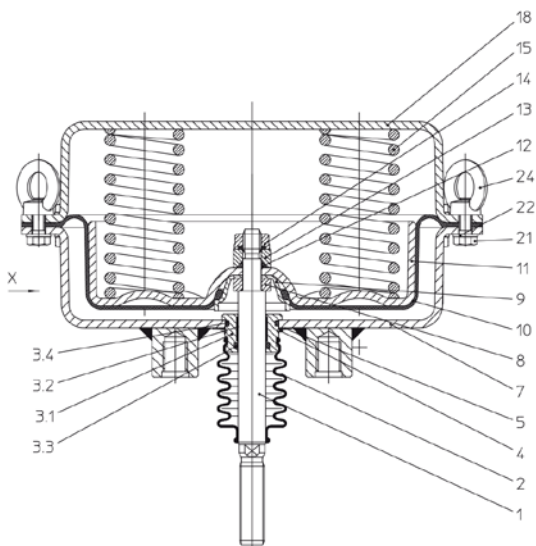
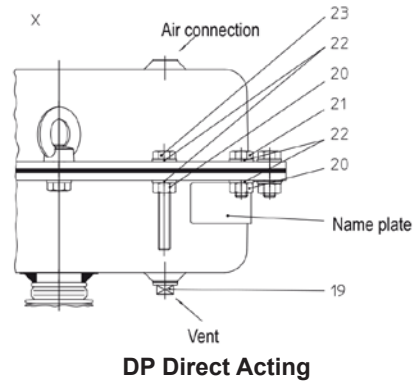
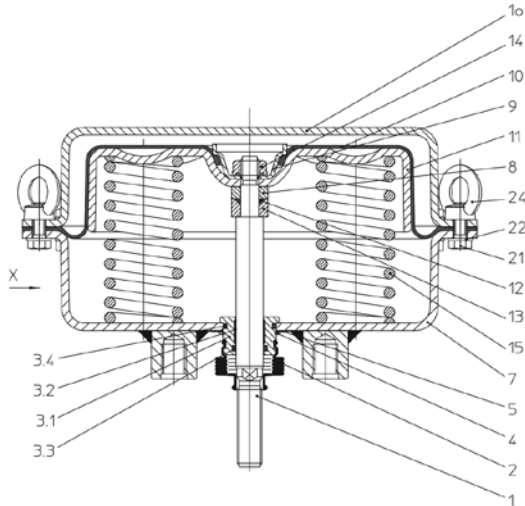

**Top Handwheel (Optional)**

**Standard Materials**

Pos.	Description	Material
1	Stem	X20Cr13+QT, 1.4021+QT
2	Bellow seal	EPDM50 or 42CR
3	Stem guiding *	X20Cr13+QT, 1.4021+QT
3.1	Stem guiding *	X20Cr13+QT, 1.4021+QT
3.2	Guiding band *	PTFE + 25%C
3.3	O-ring (stem) *	NBR
3.4	O-ring (guiding) *	NBR
3.5	Scraper *	NBR
4	Retaining ring	FSt - A3B
5	Spring plate	FSt (Fe/Zn12B)
6 / 7	Lower diaphragm casing (DP32-34Tri)	DD13+QT, 1.0335+QT (powder coated)
7	Lower diaphragm casing (DP35)	P265GH, 1.0425 / S235JR, 1.0037
8	Bushing	X20Cr13+QT, 1.4021+QT
9	Diaphragm lange	DD13+QT, 1.0335+QT (Fe/Zn12B) or X20Cr13+QT,
10	Rolling diaphragm *	1.4021+QT
11	Diaphragm plate (DP32-34Tri)	NBR + webbing
11	Diaphragm plate (DP35) *	DD13+QT, 1.0335+QT (Fe/Zn12B)
12	O-ring	St 52-3 G 03 g, 1.0570 G 03 g
13	Bushing	NBR
14	Flange nut	X20Cr13+QT, 1.4021+QT
15	Compression spring *	8 - A4G
16	Spring centring	FDSiCr
17	Spring centring	DC01, 1.0330 (Fe/Zn12B)
18	Upper diaphragm casing (DP32-34Tri)	St 52-3 G 03 g, 1.0570 G 03 g
18	Upper diaphragm casing (DP35)	DD13+QT, 1.0335+QT (powder coated)
19	Screwed cap	P265GH, 1.0425 / S235JR, 1.0037
20	Hexagon nut (DP32-34Tri) 1)	Polyäthylen
20	Hexagon nut (DP35) 1)	8 - A4G

Pos.	Description	Material
21	Hexagon screw (DP32-34Tri) 1)	C35E, 1.1181
21	Hexagon screw (DP35) 1)	8.8 - A4G
22	Washer	8.8 - A4G
23	Hexagon screw (DP32-34Tri) 1)	St - A4G
23	Hexagon screw (DP35) 1)	8.8 - A4G
24	Eye nut 1)	10.9 - A2G
34	Stem extension	8-A4G
36.1	Bellow seal *	X20Cr13+QT, 1.4021+QT
36.2	Guiding band *	X14CrMoS17+QT, 1.4104+QT
36.3	O-ring *	PTFE +25%C
36.4	O-ring *	NBR
36.5	Scraper *	NBR
37	Bushing	NBR
38	Hexagon screw	X20Cr13+QT, 1.4021+QT
39	Washer	8.8 - A4G
42	Torsion lock	X20Cr13+QT, 1.4021+QT
44 1	Distance column	8.8 - A4G
47	Stem	1SMn30+C, 1.0715+C (Fe/Zn12B)
48	Traverse	X20Cr13+QT, 1.4021+QT
50	Axial-washer	EN-JS1049, EN-GJS-400-18U-LT (Fe/Zn12B)
51	Axial-dial ring	St
52	Threaded bush	St
53	Catch pin	CuZn35Ni3Mn2Al-Pb-R490, CW710RR490
54	Lubricating nipple	St, Cu
55	Covering for traverse	5.8 - A4G
58	Handwheel	S235JR, 1.0037 (Fe/Zn12B)
59	Safety cap	Fe P01, 1.0330 (epoxy coating)

Straight Through Type Diaphragm Valves with Direct Acting Pneumatic Actuator- Rubber Diaphragm

Main Dimensions

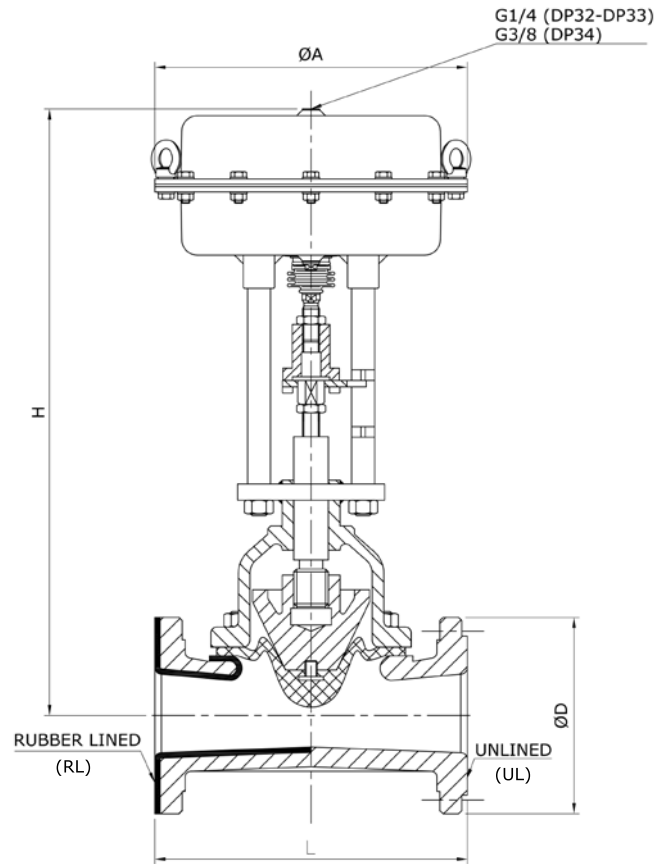
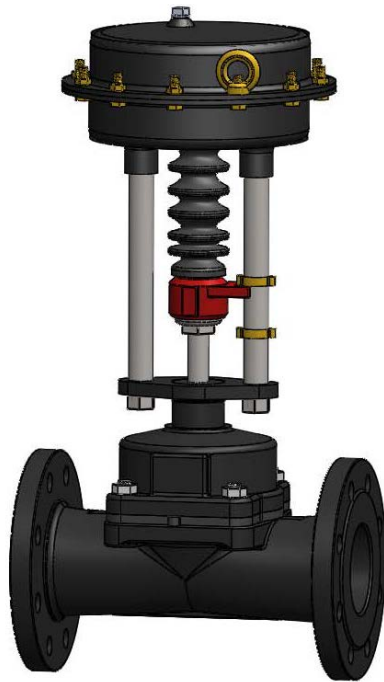

DN	L			H	ØD	ØA
	EN 558 S1 (DIN 3202 F1)		EN 558 S7 (BS 5156)			
	UL/RL	UL	RL			
15	130	108	114	420	95	250
20	150	117	123	423	105	250
25	160	127	133	453	115	250
32	180	146	152	455	140	250
40	200	159	165	463	150	250
50	230	190	196	493	165	250
65	290	216	222	685	185	250
80	310	254	260	716	200	250
100	350	305	313	754	220	405
125	400	356	364	780	250	405

Dimensions in mm subject to manufacturing tolerance.

Dimensions are based on the serialized manufacture and should be taken as preliminary.

Please, bear in mind the service clearance area when planning a skid or when installation happens in a very tight area.

Actuation Selection Chart

Direct Acting (actuator opens at air failure, springs to open/air to close).

Valve Size	Actuator Type	Max. Closing Pressure 100% ΔP (bar)	Max. Closing Pressure 0% ΔP (bar)	Air Supply to Close (bar)
DN15	DP32021020NA	8	8	2,0-2,5
DN20	DP32021020NA	8	8	2,5-3,0
DN25	DP32021030NA	8	8	2,5-3,0
DN32	DP32021030NA	8	8	2,5-3,0
DN40	DP32021030NA	8	7	2,5-3,0
DN50	DP32021030NA	8	6	4,0-4,5
DN65	DP34021050NA	8	6	2,5-3,0
DN80	DP34021065NA	8	6	3,0-3,5
DN100	DP34021065NA	8	6	3,5-4,0
DN125	DP34021065NA	6	4	4,0-4,5

Information / restriction of technical rules need to be observed!  
Installation, Operating and Maintenance Manual can be downloaded at [www.comeval.es](http://www.comeval.es)

The engineer, designing a system or a plant, is responsible for the selection of the correct valve  
Product suitability must be verified, contact manufacturer for information

Straight Through Type Diaphragm Valves with Reverse Acting Pneumatic Actuator- Rubber Diaphragm

Main Dimensions

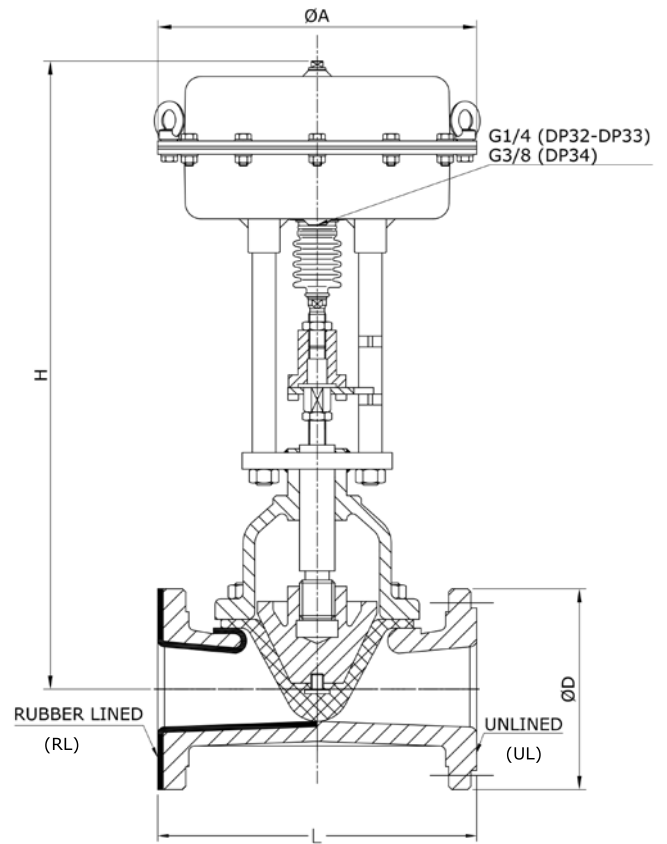
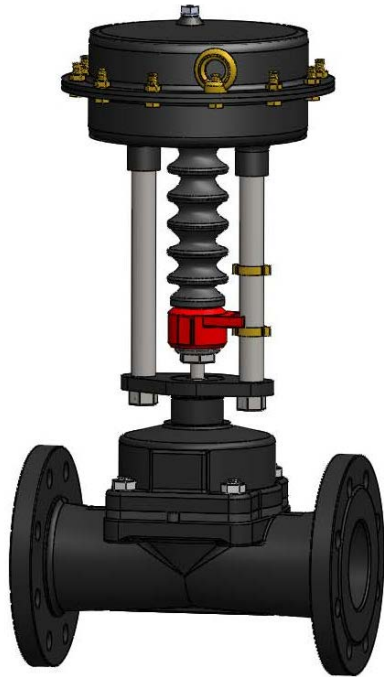

DN	L			H	ØD	ØA
	EN 558 S1 (DIN 3202 F1)		EN 558 S7 (BS 5156)			
	UL/RL	UL	RL			
15	130	108	114	420	95	250
20	150	117	123	423	105	250
25	160	127	133	453	115	250
32	180	146	152	455	140	250
40	200	159	165	463	150	250
50	230	190	196	493	165	250
65	290	216	222	685	185	250
80	310	254	260	716	200	250
100	350	305	313	754	220	405
125	400	356	364	780	250	405

Dimensions in mm subject to manufacturing tolerance.

Dimensions are based on the serialized manufacture and should be taken as preliminary.

Please, bear in mind the service clearance area when planning a skid or when installation happens in a very tight area.

Actuation Selection Chart

Reverse Acting (actuator closes at air failure, air to open/spring to close).

Valve Size	Actuator Type	Max. Closing Pressure 100% ΔP (bar)	Max. Closing Pressure 0% ΔP (bar)	Air Supply to Open (bar)
DN15	DP32041220NC	8	8	2,0-2,5
DN20	DP32082420NC	8	8	3,0-3,5
DN25	DP32082430NC	8	8	3,0-3,5
DN32	DP32082430NC	8	7	3,5-4,0
DN40	DP32082430NC	8	6	3,5-4,0
DN50	DP33153030NC	8	6	4,0-4,5
DN65	DP34082450NC	8	6	3,5-4,0
DN80	DP34102065NC	8	6	3,5-4,0
DN100	DP34204065NC	8	6	5,0-5,5
DN125	DP34204065NC	6	4	5,0-5,5

Information / restriction of technical rules need to be observed!  
Installation, Operating and Maintenance Manual can be downloaded at [www.comeval.es](http://www.comeval.es)

The engineer, designing a system or a plant, is responsible for the selection of the correct valve  
Product suitability must be verified, contact manufacturer for information

## Material Selection

Information contained in the Material Selection Chart is a combination of theoretical and application data, and should be taken as a guide only. Pressure-temperature rating, material compatibility and other parameters also to be considered for rubber selection. Please consult our Technical Department for a particular application. With constant material / process changes, Diaval® cannot accept responsibility for diaphragm and/or body material performance resulting from such changes.

Fluid	Body Material		Diaphragm		Recommendations
Abrasive slurry - non acidic	Soft rubber lined	Ductile iron	D10		
Abrasive slurry - acidic	Butyl lined		D20 or D30		
Acetic acid up to 50%	Halar® lined	FEP lined	D20 or D30		
Acetic acid over 50%	Halar® lined	FEP lined	D20 or D30		
Acetic acid (glacial)	Halar® lined	FEP lined	D20 or D30		Sealed bonnet
Acetoacetic ester	Halar® lined	Stainless steel	D90		
Acetone	Ductile iron		D20 or D30		
Acetylene	Ductile iron	Cast steel	D20 or D30		No copper
Alum	Hard rubber lined	Soft rubber lined	D10	D20 or D30	
Alumina	Ductile iron	Soft rubber lined	D20 or D30	D10	
Aluminium sulphate	Hard rubber lined	Butyl rubber lined	D10	D20 or D30	
Ammonia, aqueous	Ductile iron	Stainless steel	D10	D20 or D30	Sealed bonnet
Ammonia gaseous	Ductile iron	Stainless steel	D10	D20 or D30	Sealed bonnet
Ammonium nitrate	Butyl rubber lined	FEP lined	D20 or D30	D50	
Ammonium phosphate	Butyl rubber lined		D10	D20 or D30	
Ammonium sulphate	Butyl rubber lined		D20 or D30		
Aniline	FEP lined	Stainless steel	D92		
Antifreeze	Ductile iron	Butyl rubber lined	D20 or D30		
Apple juice	Stainless steel		D15		
Asbestos cement	Soft rubber lined	Ductile iron	D10		
Ash handling	Soft rubber lined	Ductile iron	D10		
Asphalt	Ductile iron	Cast steel	D20 or D30		
Avcat	Stainless steel	Cast steel	D70	D20 or D30	
Avgas	Stainless steel	Cast steel	D70		
Avtag	Stainless steel	Cast steel	D70	D20 or D30	
Avtur	Stainless steel	Cast steel	D70	Butyl	
Barium carbonate	Hard rubber lined	Stainless steel	D20 or D30	D50	
Barium sulphate	Soft rubber lined	Hard rubber lined	D20 or D30		
Barytes	Soft rubber lined	Hard rubber lined	D10		
Basic slag	Soft rubber lined	Ductile iron	D10		
Battery acid	Hard rubber lined	Butyl rubber lined	D20 or D30		
Bauxite	Soft rubber lined		D10		
Beet juice	Ductile iron	Hard rubber lined	D20 or D30		
Benzene	Butyl rubber lined	Halar® lined	D92		
Benzyl alcohol	FEP lined	Halar® lined	D92		Sealed bonnet
Bilge (ships)	Ductile iron	Cast steel	D40		
Blast furnace gas	Ductile iron	Ductile iron	D20 or D30		
Bleaching powder	Hard rubber lined	Hypalon lined	D60		
Borax	Hard rubber lined		D10		
Brine	Hard rubber lined	Stainless steel	D10	D92	
Brine, chlorinated	Hard rubber lined	Hypalon lined	D60		
Bromine	FEP lined		D92		Sealed bonnet
Bcf	Ductile iron		D92		
Butane	Ductile iron	Cast steel	D40	D50	Sealed bonnet
Butanol	Ductile iron	Cast steel	D20 or D30		
Calcium carbonate	Ductile iron	Soft rubber lined	D10	D20 or D30	
Calcium chloride	Hard rubber lined		D10	D20 or D30	
Calcium hydroxide	Ductile iron	Soft rubber lined	D10	D20 or D30	



**Material Selection**

Fluid	Body Material		Diaphragm		Recomendations
Calcium hypochlorie	Hard rubber lined	Ductile iron	D60	D10	
Calcium phosphate	Butyl rubber lined	Hard rubber lined	D10	D20 or D30	
Calcium sulphate	Soft rubber lined	Ductile iron	D10	D20 or D30	
Calor gas	Ductile iron		D40		
Cane juice	Ductile iron	Soft rubber lined	D20 or D30		
Carbon black	Soft rubber lined	Ductile iron	D10		
Carbon dioxide	Ductile iron	Ductile iron	D20 or D30		
Carbon monoxide	Ductile iron		D20 or D30		Sealed bonnet
Carbon tetrachloride	Ductile iron	Ductile iron	D92		
Castor oil	Ductile iron		D20 or D30		
Caustic potash	Ductile iron	Butyl rubber lined	D10	D20 or D30	Sealed bonnet
Caustic soda	Ductile iron	Butyl rubber lined	D10	D20 or D30	Sealed bonnet
Cement (dry and slurry)	Soft rubber lined	Ductile iron	D10		
Chalk	Ductile iron	Soft rubber lined	D10		
China clay	Ductile iron	Soft rubber lined	D10		
Chlorinated brine	FEP lined	Hard rubber lined	D60	D10	
Chlorine gas dry	Ductile iron	Halar® lined	D97		
Chlorine gas moist	FEP lined	Halar® lined	D97		
Chlorine gas wet	FEP lined	Halar® lined	D97		
Chlorine water	Hard rubber lined	Halar® lined	D10		
Chloroform	FEP lined	Stainless steel	D92		
Chrome alum	Butyl rubber lined	Halar® lined	D20 or D30		
Chrome plating solns	Butyl rubber lined	Halar® lined	D20 or D30		
Chrome tanning solns	Butyl rubber lined	Halar® lined	D20 or D30	D92	
Clays and slips	Soft rubber lined	Ductile iron	D10		
Coal dust	Soft rubber lined	Ductile iron	D10		
Coal gas	Ductile iron	Ductile iron	D20 or D30	D40	
Coal slurry	Soft rubber lined	Ductile iron	D10		
Coke oven gas	Ductile iron	Ductile iron	D20 or D30	D40	
Compressed air (oil free)	Ductile iron	Cast steel	D40	D20 or D30	
Compressed air (oily)	Ductile iron	Cast steel	D40	D70	
Concrete	Soft rubber lined	Ductile iron	D10		
Copper plating solutions	Butyl rubber lined	Halar® lined	D20 or D30		
Copper sulphate	Butyl rubber lined	Halar® lined	D20 or D30		
Creosote	Hard rubber lined	Halar® lined	D70		
Creosote	Ductile iron	Halar® lined	D70		
Crude oil	Cast steel	Ductile iron	D70	D92	
Cutting oil	Hard rubber lined		D40		
Demineralised water	Hard rubber lined	Stainless steel	D20 or D30	D92	
Detergents	Hard rubber lined	Halar® lined	D20 or D30	D10	
Dibutyl phthalate	Halar® lined	Ductile iron	D92		
Dichlorodiluoromethane	Ductile iron	Cast steel	D92		
Diesel oil	Ductile iron	Cast steel	D70		
Diethyl ether	Stainless steel	Ductile iron	D92		Sealed bonnet
Diethylene glycol	Ductile iron	Stainless steel	D20 or D30		
Disinfectant (general)	Ductile iron	Halar® lined	D50		
Dye liquors	FEP lined	Butyl rubber lined	EPDM	D20 or D30	
Electrolytic tinplating solutions	Butyl rubber lined	FEP lined	D20 or D30		
Ethane	Ductile iron	Cast steel	D40	D50	
Ethanol	Ductile iron	Stainless steel	D20 or D30	D20 or D30	
Ether	Ductile iron	Stainless steel	D92		Sealed bonnet
Ethyl acetate	Stainless steel	Halar® lined	D20 or D30		
Ethyl alcohol	Ductile iron	Stainless steel	D20 or D30		
Ethylene	Ductile iron	Stainless stee	D20 or D30		

**Material Selection**

Fluid	Body Material		Diaphragm	Recomendations	
Ethylene glycol	Ductile iron	Stainless steel	D20 or D30		
Ferric sulphate	Butyl rubber lined	Halar® lined	D10		
Fertilizers (dry powders)	Soft rubber lined	Ductile iron	D10		
Fertilizer slurries (wet process)	Butyl rubber lined	Ductile iron	D20 or D30	D20 or D30	
Fire foam	Ductile iron	Cast steel	D40		
Flue gas	Ductile iron	Cast steel	D40	D20 or D30	
Fly ash	Ductile iron	Soft rubber lined	D10	Butyl	
Freon	Ductile iron	Ductile iron	D92	D50	
Fuel oil	Ductile iron	Cast steel	D40		
Gas (coal)	Ductile iron	Cast steel	D40		
Gas (natural)	Ductile iron	Cast steel	D40		
Gasoline	Cast steel	Ductile iron	D70		
Glucose	Stainless steel	Stainless steel	D20 or D30		
Glycerine	Stainless steel	Hard rubber lined	D20 or D30		
Gravel	Soft rubber lined	Ductile iron	D10		
Grease	Ductile iron	Cast steel	D40		
Gypsum	Soft rubber lined	Ductile iron	D10		
Hydraulic oils (vegetable based)	Ductile iron	Ductile iron	D20 or D30		
Hydraulic oils (mineral based)	Ductile iron	Ductile iron	D40		
Hydrobromic acid	FEP lined	Halar® lined	D92		
Hydrochloric acid	Hard rubber lined	Halar® lined	D10	D92	
Hydrofluoric acid	Butyl rubber lined	Halar® lined	D20 or D30		
Hydrogen	Ductile iron	Cast steel	D20 or D30	D10	Sealed bonnet
Hydrogen peroxide	Hard rubber lined	Stainless steel	PTFE/D70	D20 or D30	
Hypo	Hard rubber lined	Halar® lined	D10	D60	
Inert gases	Ductile iron	Ductile iron	D20 or D30		
Inks	Stainless steel	Halar® lined	D92	D20 or D30	
Insecticide solutions	Ductile iron	Ductile iron	D40	D20 or D30	
Instrument air	Ductile iron	Stainless steel	D20 or D30	D40	
Iron oxide slurry	Soft rubber lined	Ductile iron	D20 or D30		
Isopropanol	Ductile iron	Hard rubber lined	D10	D20 or D30	
Kaolin	Soft rubber lined	Ductile iron	D10		
Kerosene	Ductile iron	Stainless steel	D70	D92	
Laundry bleach	Hard rubber lined	Halar® lined	D60	D10	
Lime	Ductile iron	Soft rubber lined	D10		
Liquid parafin	Ductile iron	Ductile iron	D40	D70	
Liquid petroleum gases (I.P.G.)	Ductile iron	Cast steel	D40	D20 or D30	Sealed bonnet
Lubricating oils	Hard rubber lined	Cast steel	D40	D70	
Magnesium chloride	Ductile iron	Butyl rubber lined	D10	D20 or D30	
Magnesium oxide	Butyl rubber lined	Hard rubber lined	D10	D20 or D30	
Magnesium sulphate	Soft rubber lined	Ductile iron	D10	D20 or D30	
Magnetite	Hard rubber lined	Ductile iron	D10		
Methane	Ductile iron	Ductile iron	D20 or D30	D40	
Methanol	Ductile iron	Stainless steel	D20 or D30		
Methanol/water mixture	Ductile iron	Hard rubber lined	D20 or D30	D10	
Methylated spirits	Ductile iron	Stainless steel	D20 or D30		
Methyl ethyl ketone (mek)	Stainless steel	FEP lined	D92		
Methyl isobutyl ketone	Stainless steel	FEP lined	D92	D20 or D30	
Milk	Stainless steel		D15		
Mineral oil	Ductile iron	Cast steel	D70	D40	
Molasses	Ductile iron	Stainless steel	D20 or D30		
Monosodium glutamate	Hard rubber lined	Stainless steel	D10		



**Material Selection**

Fluid	Body Material		Diaphragm		Recomendations
Mortar and cement	Soft rubber lined	Ductile iron	D10	D20 or D30	
Naphtha	Ductile iron	Cast steel	D70		
Napthalene	Ductile iron	Cast steel	D70		
Natural gas	Ductile iron	Stainless steel	D40	D50	
Nickel plating solutions	Butyl rubber lined	Halar® lined	D20 or D30	D60	
Nickel plating sludge	Butyl rubber lined	Halar® lined	D20 or D30	D60	
Nitric acid	FEP lined	Stainless steel	D92	D70	Check grade of S.S.
Nitric acid / hydrofluoric acid mix	FEP lined	Halar® lined	D92		
Nitrogen	Ductile iron	Stainless steel	D20 or D30		
Nitrous oxide (dry)	Stainless steel	FEP lined	D20 or D30		
Oils, animal	Ductile iron	Stainless steel	D40	D92	
Oils, cutting	Ductile iron	Stainless steel	D70	D40	
Oil fuel	Ductile iron	Stainless steel	D70	D40	
Oils, lubricating	Ductile iron	Stainless steel	D70	D40	
Oils, mineral	Ductile iron	Cast steel	D70	D40	
Oil, rolling	Ductile iron	Cast steel	D70	D40	
Oil, transformer	Ductile iron	Stainless steel	D70	D40	
Oils, vegetable	Stainless steel	Ductile iron	D40	D70	
Oleum	FEP lined	Halar® lined	D92		
Olive oil	Stainless steel	Ductile iron	D40	D92	
Oxygen	Ductile iron	Stainless steel	D50	D20 or D30	Degreased for oxygen
Paint (oil based)	Ductile iron	Stainless steel	D40	D20 or D30	
Paint (water based)	Ductile iron	Stainless steel	D20 or D30	D92	
Paper pulp	Hard rubber lined	Butyl rubber lined	D10	D20 or D30	
Paper stock	Hard rubber lined	Butyl rubber lined	D10	D20 or D30	
Parafin	Ductile iron	Stainless steel	D70	D40	
Parafin wax	Ductile iron	Cast steel	D40	D70	
Paraquet	Ductile iron	Halar® lined	D40		Sealed bonnet
Pentane	Ductile iron	Cast steel	D70	D92	
Perchloroethylene	Ductile iron	Cast steel	D70	D92	
Petrol	Ductile iron	Cast steel	D70		Sealed bonnet
Petroleum jelly	Ductile iron	Halar® lined	D70	D40	
Phosphoric acid	Butyl rubber lined	Halar® lined	D20 or D30		
Photographic developers	Halar® lined	FEP lined	D20 or D30	D92	
Plating solutions	Butyl rubber lined	Halar® lined	D20 or D30		
Polyethylene glycol	Ductile iron	Stainless steel	D10	D20 or D30	
Potassium chloride	Hard rubber lined	Halar® lined	D10	D20 or D30	
Potassium cyanide	Hard rubber lined	Halar® lined	D10	D20 or D30	Sealed bonnet
Potassium ferricyanide	Hard rubber lined	Halar® lined	D20 or D30	D10	
Potassium hydroxide	Ductile iron	Hard rubber lined	D20 or D30	D10	Sealed bonnet
Potassium hypochlorite	Hard rubber lined	Halar® lined	D60	D10	
Potassium phosphate	Hard rubber lined	Butyl rubber lined	D20 or D30	D10	
Pottery slip	Soft rubber lined	Ductile iron	D10		
Producer gas	Ductile iron	Cast steel	D20 or D30	D40	
Propane (gas or liquid)	Ductile iron	Cast steel	D40	D50	
Radioactive effluents	Butyl rubber lined	Stainless steel	D20 or D30		No copper parts.
Rock salt	Soft rubber lined	Hard rubber lined	D10	D20 or D30	
Rolling oil	Ductile iron	Cast steel	D70	D10	
Salt	Soft rubber lined	Hard rubber lined	D10	D20 or D30	
Sand	Soft rubber lined	Ductile iron	D10	D20 or D30	
Sea water	Stainless steel	Hard rubber lined	D10	D20 or D30	
Sewage	Ductile iron	Hard rubber lined	D10	D50	
Silver plating solutions	Butyl rubber lined	Halar® lined	D20 or D30		

**Material Selection**

Fluid	Body Material		Diaphragm		Recomendations
Slaked lime	Ductile iron	Soft rubber lined	D10	D20 or D30	
Slip (pottery)	Soft rubber lined	Ductile iron	D10		
Soap lye	Ductile iron	Butyl rubber lined	D10	D20 or D30	
Soap solutions	Ductile iron	Butyl rubber lined	D10	D20 or D30	
Sodium bicarbonate	Ductile iron	Halar® lined	D20 or D30	D92	
Sodium chloride	Soft rubber lined	Hard rubber lined	D10	D20 or D30	
Sodium hydroxide	Ductile iron	Hard rubber lined	D20 or D30	D10	Sealed bonnet
Sodium hydroxide (oily)	Ductile iron	Stainless steel	D50	D40	
Sodium hypochlorite	Hard rubber lined	Halar® lined	D10	D70	
Solvent naphtha	Ductile iron	Cast steel	D70	D40	
Stannic chloride	Halar® lined	FEP lined	D20 or D30	D92	
Starch solutions	Ductile iron	Halar® lined	D20 or D30	D60	
Stearic acid	Stainless steel	Halar® lined	D92		
Sugar	Ductile iron	Stainless steel	D20 or D30	D15	
Sulphur dioxide	Butyl rubber lined	Hard rubber lined	D20 or D30		
Sulphuric acid below 75%	Butyl rubber lined	Halar® lined	D20 or D30	D70	
Sulphuric acid 75-95%	Halar® lined	FEP lined	D92	D70	
Sulphuric acid 95-99%	Ductile iron	Halar® lined	D92	D70	Sealed bonnet
Sulphuric acid over 99%	FEP lined	Halar® lined	D92		
Syrups (sugar)	Ductile iron	Stainless steel	D20 or D30	D15	
Tetrachloroethane	Ductile iron	Stainless steel	D92	D70	Sealed bonnet
Textile dyes	Halar® lined	Butyl rubber lined	D20 or D30	D92	
Tin plating solutions	Halar® lined	Butyl rubber lined	D92	D20 or D30	
Titanium dioxide	Butyl rubber lined	Hard rubber lined	D20 or D30	D10	
Toluene	Ductile iron	Cast steel	D92		
Transformer oil	Stainless steel	Ductile iron	D70		
Trichloroethylene	Ductile iron	Stainless steel	D92	D70	Sealed bonnet
Turpentine	Ductile iron	FEP lined	D40	D70	Sealed bonnet
Vegetable oils	Ductile iron	Stainless steel	D70	D92	
Vinegar	Stainless steel		D92		
Water cold	Ductile iron	Stainless steel	D10	D20 or D30	
Water de-mineralised	Hard rubber lined	FEP lined	D10	D92	
Water drinking	Stainless steel	Stainless steel	D20 or D30		
Water oily	Ductile iron	Gunmetal	D40	D50	
Water (salt and brackish)	Stainless steel	Hard rubber lined	D10	D20 or D30	
Wood pulp	Ductile iron	Soft rubber lined	D10	D20 or D30	
Wort	Ductile iron	Stainless steel	D20 or D30		
Xylene	Ductile iron	Cast steel	D92	D70	
Zinc chloride	Soft rubber lined	Stainless steel	D10	D20 or D30	
Zinc oxide	Stainless steel	Butyl rubber lined	D20 or D30	D92	
Zinc plating solutions	Butyl rubber lined	Hard rubber lined	D20 or D30		