

## Register 12 CONTENTS - AKH2.2

<b>Contents</b>	<b>Page</b>
<i>Technical Data AKH2.2-DIN</i> .....	2
<i>Technical Data AKH2.2-ANSI</i> .....	3
<i>Material Specification AKH2.2</i> .....	4
<i>Dimensions AKH2.2-DIN</i> .....	5
<i>Dimensions AKH2.2-ANSI</i> .....	6
<i>Spare Parts AKH2.2 Standard - DIN / ANSI</i> .....	7
<i>Assembly Instructions AKH2.2</i> .....	8
<i>Disassembly Instructions AKH2.2</i> .....	9
<i>AKH2.2 - Recommended Tightening Torques</i> .....	10
<i>AKH2.2 - Manual Actuator</i> .....	11
<i>AKH2.2 - Material specification</i> .....	11
<i>Material specification - AKH2.2 with manual actuator</i> .....	12
<i>AKH2.2 - Actuator sizing torques</i> .....	13
<i>AKH2.2 with actuator mounting (drawing)</i> .....	14
<i>Material Specification - AKH2.2 with actuator mounting</i> .....	15
<i>AKH2.2 - Dimension Sheet for actuator mounting acc. to NAMUR-recommendation</i> .....	16
<i>AKH2.2/DA - Vented Seatrings</i> .....	17
<i>Material Specification AKH2.2/DA</i> .....	18
<i>Assembly Instruction- AKH2.2/DA</i> .....	19
<i>AKH2.2 - <math>K_v</math> and <math>C_v</math> - Data</i> .....	20
<i>Optional C-ball in ball valves</i> .....	21
<i>Optional V-ball in ball valves</i> .....	22

## Technical Data AKH2.2 DIN

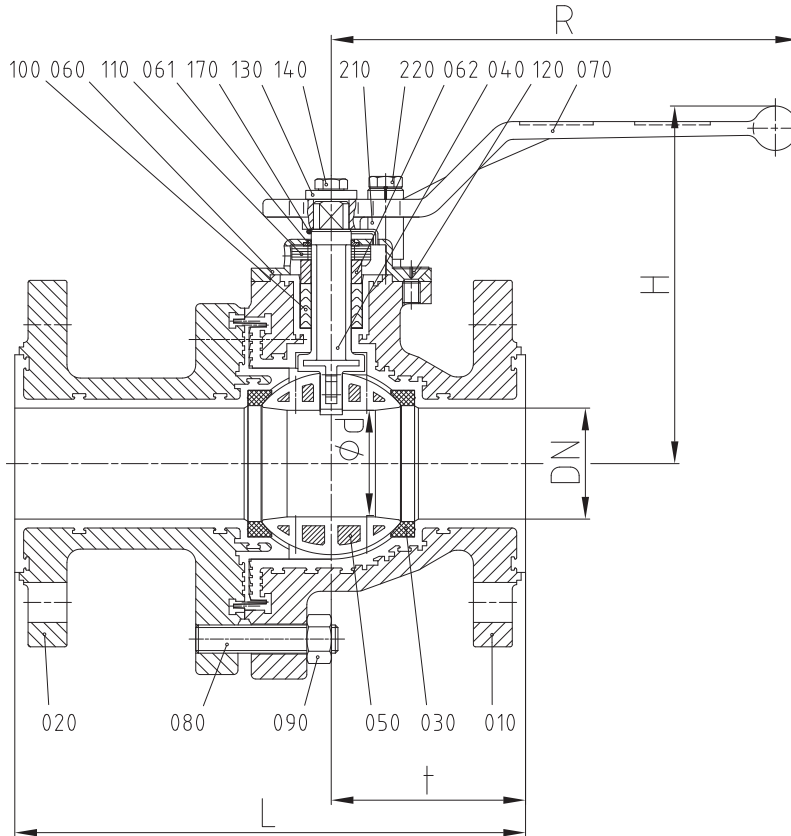

Face to Face Dimensions    DIN EN 558 (Basic series 1)  
 Flange Connection            DIN EN 1092-2 PN 16

DN / DIN		L	H	R	t	Ød	weight	
<b>015</b>	mm	130	120	160	59,5	15	kg	4,0
	inch	5,12	4,72	6,3	2,34	0,59	lbs	8,8
<b>020</b>	mm	150	120	160	69,5	20	kg	4,8
	inch	5,9	4,72	6,3	2,7	0,79	lbs	10,6
<b>025</b>	mm	160	123	160	65,5	24	kg	5,4
	inch	6,3	4,84	6,3	2,58	0,94	lbs	11,9
<b>032</b>	mm	180	145	210	80	32	kg	10,2
	inch	7,09	5,71	8,27	3,15	1,26	lbs	22,4
<b>040</b>	mm	200	145	210	80	38	kg	10,7
	inch	7,87	5,71	8,27	3,15	1,5	lbs	23,5
<b>050</b>	mm	230	160	210	87,5	48	kg	14,1
	inch	9,06	6,3	8,27	3,44	1,89	lbs	31,0
<b>065</b>	mm	290	200	313	108	65	kg	24,0
	inch	11,42	7,87	12,32	4,25	2,56	lbs	52,8
<b>080</b>	mm	310	207	313	118	80	kg	31,0
	inch	12,2	8,15	12,32	4,65	3,15	lbs	68,2
<b>100</b>	mm	350	220	313	140	100	kg	47,5
	inch	13,78	8,66	12,32	5,51	3,94	lbs	104,5

## Technical Data AKH2.2 ANSI

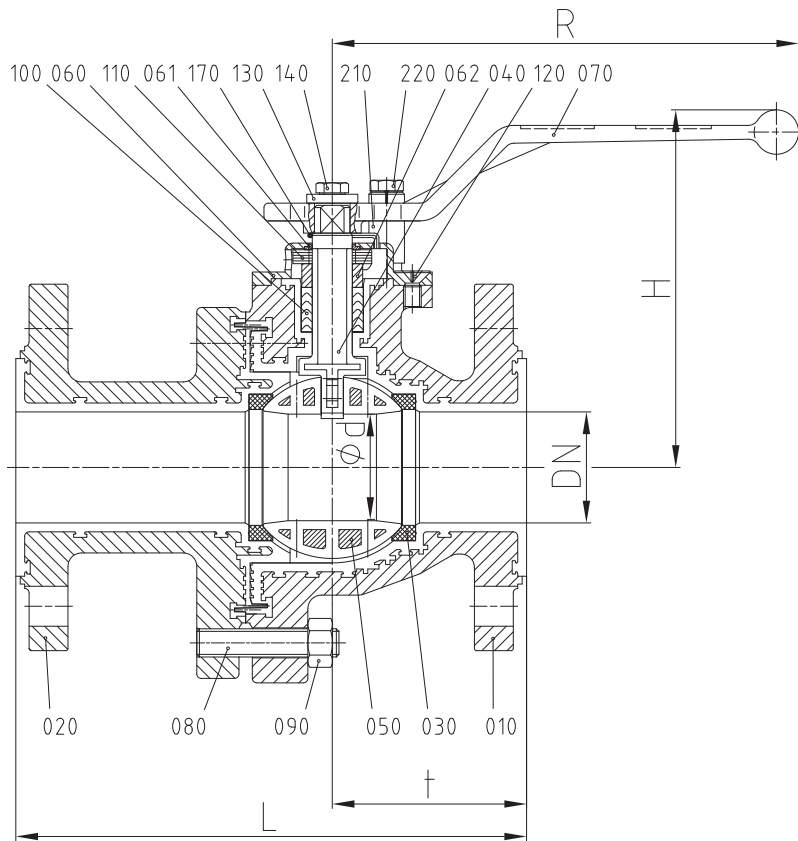

Flange Connections ANSI B 16.5 - 150lbs

DN / ANSI		L	H	R	t	Ød	weight	
1/2" *	inch	5,12	4,72	6,3	2,34	0,59	lbs	9,5
	mm	130	120	160	59,5	15	kg	4,3
3/4" *	inch	5,9	4,72	6,3	2,74	0,79	lbs	10,1
	mm	150	120	160	69,5	20	kg	4,6
1"	inch	6	4,84	6,3	2,58	0,94	lbs	11,0
	mm	152,4	123	160	65,5	24	kg	5,0
1 1/2"	inch	7	5,71	8,27	3,11	1,5	lbs	18,5
	mm	178	145	210	79	38	kg	8,4
2"	inch	8	6,3	8,27	3,44	1,89	lbs	28,2
	mm	203	160	210	87,5	48	kg	12,8
3"	inch	9,5	8,15	12,32	4,65	3,15	lbs	64,0
	mm	241	207	313	118	80	kg	29,1
4"	inch	11,5	8,66	12,32	5,51	3,94	lbs	95,7
	mm	292	220	313	140	100	kg	43,5

\* Face-toFace Dimensions acc. to DIN EN 558 (Basic series 1)

## Material specification AKH2.2

No.	Designation	Pieces	Material	Material-No. / DIN	ASTM / AISI
010	body	1	ductile iron / PFA ductile iron / FEP °	EN-JS1049 (GGG-40.3) / DIN EN 1563	A 395
020	side piece	1	ductile iron / PFA ductile iron / FEP °	EN-JS1049 (GGG-40.3) / DIN EN 1563	A 395
030	seat ring	2	PTFE	pure - PTFE	
040	stem	1	stainless steel / PFA Hastelloy C4 / PFA °°	1.4470 / DIN EN 10283 2.4610 / DIN 17744	A 890 CD3MN
050	ball				
	DN 15-25, 40-50, DN ½" - 2"	1	cast steel / PFA cast steel / FEP°	1.0619 / DIN EN 10213-2	ASTM A216 Grade WCB
	DN 32, 65 - 100, DN 3" - 4"	1	ductile iron / PFA ductile iron / FEP ° ceramic Al <sub>2</sub> O <sub>3</sub> *	EN-JS1049 (GGG-40.3) / DIN EN 1563	A 395
060	top cap	1	steel casting	1.4308 / DIN EN 10283	A 743 CF-8
061	bush	1	PTFE		
062	spacer	1	stainless steel	1.4104 / DIN EN 10088-3	A430 F
070	hand lever				
	DN 15-50, ½" - 2"	1	die cast metall (galvanizing)	ZP0410 / DIN EN 12844	
	DN 65-100, 3" - 4"	1	malleable cast iron (galvanizing)	EN-GJS-50-7 (GGG-50)	
080	stud bolt				
	DN 15, 20, 32, DN ½"-4"	1 set	stainless steel	1.4301-K70 / DIN EN 10088-3	A 193 B8
	hexagon bolt				
	DN 25, 40, 50, 65, 80, 100	1 set	stainless steel	1.4301-K70 / DIN EN 10088-3	A 193 B8
090	hexagon nut	1 set	stainless steel	1.4301-K70 / DIN EN 10088-3	A 194 8
100	packing material (chevron)	1 set	PTFE ° PTFE-graphite °		
110	belleville washer	5	stainless steel	1.4310 / DIN EN 10270-3	AISI 301
120	countersunk screw	1 set	stainless steel	1.4301 / DIN EN 10088-3	A 193 B8
130	lock washer	1	stainless steel	1.4301 / DIN EN 10088-3	AISI 304
140	hexagon bolt	1	stainless steel	1.4301 / DIN EN 10088-3	A 193 B8
170	grounding device				
	DN 25, 50 - 100 DN 1", 2" - 4"	1	stainless steel	1.4310 / DIN EN 10270-3	AISI 301
	curved spring washer				
	DN 15, 20, 32, 40 DN ½", ¾", 1½"	1	stainless steel	1.4301 / DIN EN 10088-3	A 193 B8
210	stop				
	DN 15 - 100, ½" - 4"	1	steel (galvanizing)	1.0037 / DIN EN 10025-2	A 283 B
220	hexagon bolt	1	stainless steel	1.4301 / DIN EN 10088-3	A 193 B8

\* ceramic ball on request  
 °° Hastelloy stem on request  
 ° optional

## Dimensions AKH2.2 DIN

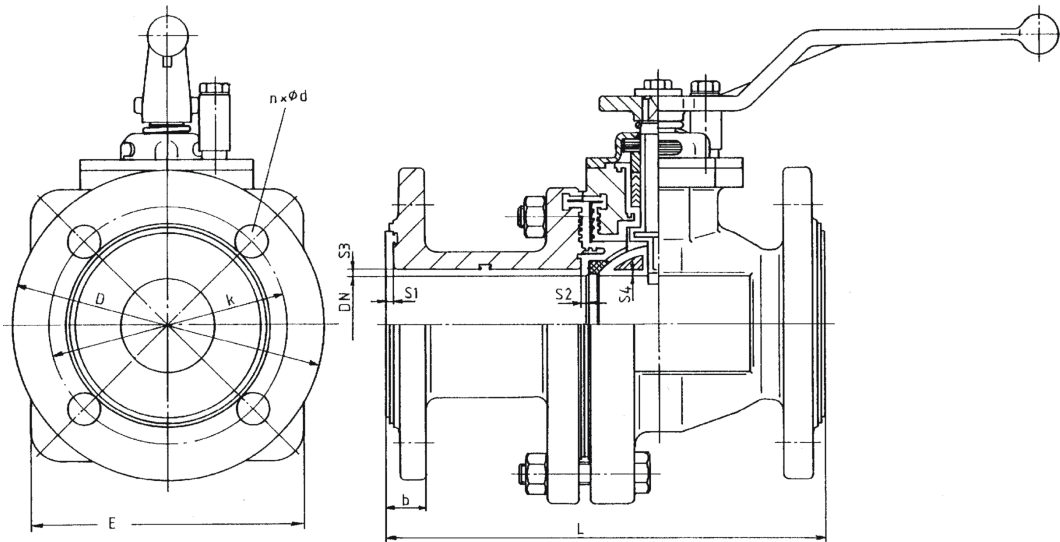

DIN		L	E°	b	D	k	nxØd	S1	S2	S3	S4
<b>015</b>	mm	130	107	15	95	65	4x14	3,5	3,5	3,5	5
	inch	5,12	4,21	0,59	3,74	2,56	4x0,55	0,14	0,14	0,14	0,2
<b>020</b>	mm	150	107	16	105	75	4x14	3,5	3,5	3,5	2,5
	inch	5,9	4,21	0,63	4,13	2,95	4x0,55	0,14	0,14	0,14	0,1
<b>025</b>	mm	160	106	17	115	85	4x14	3	3	3,5	2,5
	inch	6,3	4,17	0,67	4,53	3,35	4x0,55	0,12	0,12	0,14	0,1
<b>032</b>	mm	180	124	20,5	140	100	4x18	4	3,5	4	3,5
	inch	7,09	4,88	0,81	5,51	3,94	4x0,71	0,16	0,14	0,16	0,14
<b>040</b>	mm	200	124	20,5	150	110	4x18	4	3,5	4	3
	inch	7,87	4,88	0,81	5,91	4,33	4x0,71	0,16	0,14	0,16	0,12
<b>050</b>	mm	230	144	21,5	165	125	4x18	4	3,5	4	3
	inch	9,06	5,67	0,85	6,5	4,92	4x0,71	0,16	0,14	0,16	0,12
<b>065</b>	mm	290	190	24,5	185	145	4x18	4	3,5	4,5	3,5
	inch	11,42	7,48	0,96	7,28	5,71	4x0,71	0,16	0,14	0,18	0,14
<b>080</b>	mm	310	230	26,5	200	160	8x18	4	4	4,5	4,25
	inch	12,2	9,06	1,04	7,87	6,3	8x0,71	0,16	0,16	0,18	0,17
<b>100</b>	mm	350	250	30,5	220	180	8x18	4	5	5	4,5
	inch	13,78	9,84	1,2	8,66	7,09	8x0,71	0,16	0,2	0,2	0,18

Stem lining DN 15, 20 and 25 is 0,059 inch. All other sizes at least is 0,098 inch.  
 ° DN 080, DN 100 octagonal

# Technical Manual

## Dimensions AKH2.2 ANSI

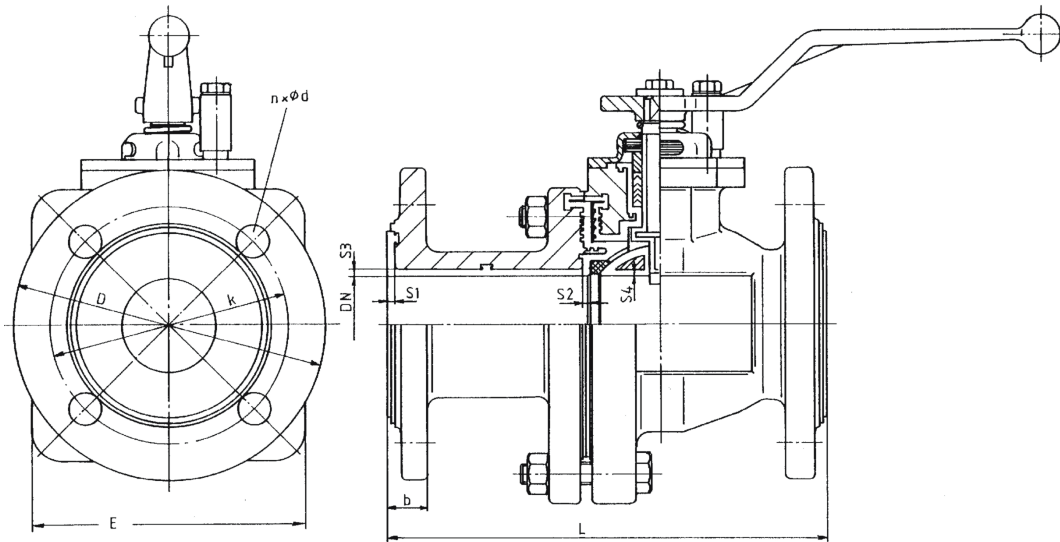

DN / ANSI		L	E°	b	D	k	nxØd	S1	S2	S3	S4
1/2"	inch	5,12	4,21	0,59	3,5	2,38	4x0,63	0,14	0,14	0,14	0,2
	mm	130	107	15	88,9	60,5	4x16	3,5	3,5	3,5	5
3/4"	inch	5,9	4,21	0,63	3,88	2,75	4x0,63	0,14	0,14	0,14	0,1
	mm	150	107	16	98,5	70	4x16	3,5	3,5	3,5	2,5
1"	inch	6	4,17	0,67	4,25	3,13	4x0,63	0,12	0,12	0,14	0,1
	mm	152,4	106	17	107,9	79,2	4x16	3	3	3,5	2,5
1 1/2"	inch	7	4,88	0,77	5	3,88	4x0,63	0,16	0,14	0,16	0,12
	mm	178	124	19,5	127	98,5	4x16	4	3,5	4	3
2"	inch	8	5,67	0,85	6	4,75	4x0,75	0,16	0,14	0,16	0,12
	mm	203	144	21,5	152,4	120,5	4x19	4	3,5	4	3
3"	inch	9,5	9,06	1,04	7,5	6	8x0,75	0,16	0,16	0,18	0,17
	mm	241	230	26,5	190,5	152,5	8x19	4	4	4,5	4,25
4"	inch	11,5	9,84	1,2	9	7,5	8x0,75	0,16	0,2	0,2	0,18
	mm	292	250	30,5	228,6	190,5	8x19	4	5	5	4,5

Stem lining DN 1/2", 3/4", 1" is 0,059 inch. All other sizes at least is 0,098 inch.  
 ° DN 3", 4" octagonal

## Spare Parts (item n°) - AKH2.2 Standard Version

DIN	ANSI	Ball			Seat Rings
		FEP	PFA	Ceramic <sup>°</sup>	PTFE
015	1/2"	0000266	0000321	0002316	0008221
020	3/4"	0000267	0000322	0002316	0008221
025	1"	0000268	0000323	0002317	0008221
032	-	0000269	0000324	---	0009226
040	1 1/2"	0000270	0000325	0002319	0008222
050	2"	0000271	0000326	0002320	0008223
065	-	0000272	0000327	0002321	0008224
080	3"	0000273	0000328	0002322	0008225
100	4"	0000274	0000329	0002323	0008226

DIN	ANSI	Stem		Packing (set)	
		Stainless Steel / PFA	Hastelloy / PFA	PTFE	PTFE / Graphite
015	1/2"	0000113	0000114	0010366	0014260
020	3/4"	0000113	0000114	0010366	0014260
025	1"	0000115	0000116	0010366	0014260
032	-	0000117	0000118	0010966	0019209
040	1 1/2"	0000117	0000118	0010966	0019209
050	2"	0000119	0000120	0010967	0017445
065	-	0000121	0000122	0010731	0019210
080	3"	0000121	0000122	0010731	0019210
100	4"	0000121	0000122	0010731	0019210

<sup>°</sup> Al<sub>2</sub>O<sub>3</sub>

## Assembly instructions AKH2.2

*The general installation and maintenance instructions must be observed.*

1. Insert stem **(040)** from inside of body in such a way that the flat side is parallel to body longitudinal axis.
2. Insert chevron packing **(100)** and spacer **(062)**.
3. Install belleville washers **(110)** on spacer (in alternating layers).
4. Install top cap **(060)** and bush **(061)** on valve body using countersunk screws **(120)**.
5. Install grounding device **(170)** also on valves with actuator.
6. Install hand lever **(070)** on to stem **(040)** and tighten it using lock washer **(130)** and hexgon screw **(140)**.
7. Insert first ball seat ring **(030)** into body **(010)**.
8. Insert ball **(050)** to valve stem by pushing the ball in a downward motion through valve body.
9. Turn hand lever 90° off longitudinal axis of body.
10. Install second ball seat ring **(030)** on to ball **(050)**.
11. Install side piece **(020)** on to body **(010)**.
12. Install hexagon bolts **(080)** or respectively stud bolts and hexagon nuts **(090)** and tighten by crisscross method to recommended torques.
13. Install lever stop **(210)** using hexagon bolt **(220)**.

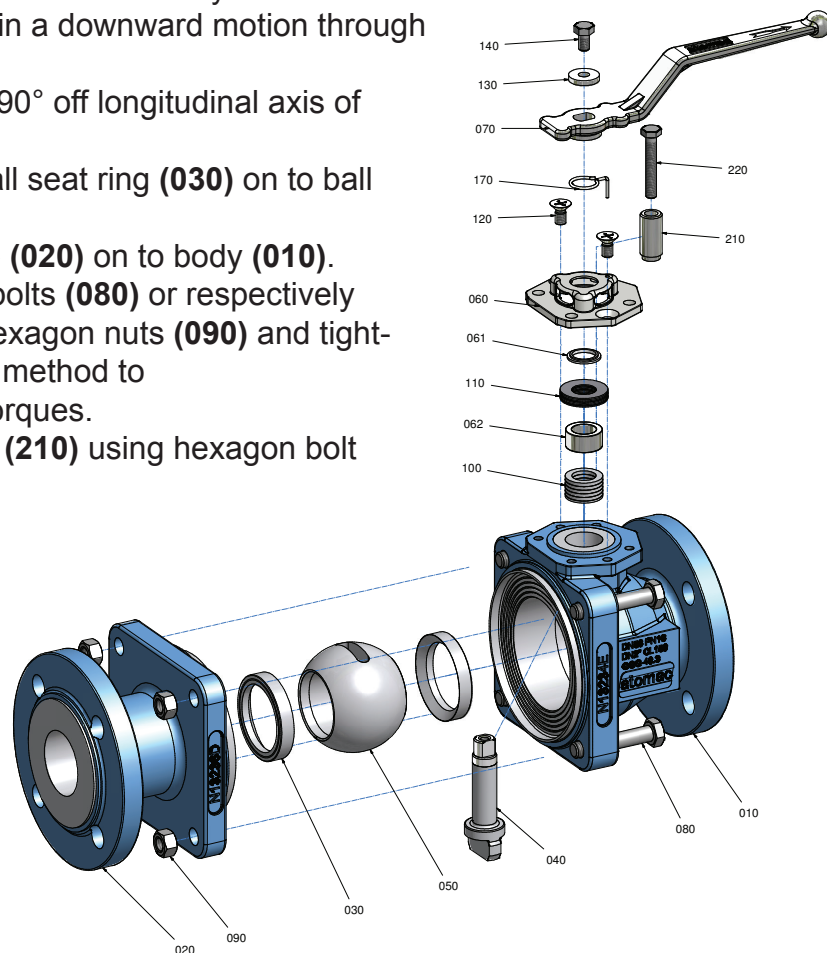



## Disassembly instructions AKH2.2

*For all jobs which are to be carried out on an installed valve, the works safety requirements and the general accident prevention instructions must be observed. Moreover, the general installation and maintenance instructions for fluorocarbon resin-lined atomac valves must be considered.*

1. Prior to disassembly, the valve must be cleaned from all fluid according to the above mentioned instructions. Particular care must be taken that during the rinsing and draining of the piping, the valve is opened and closed repeatedly. Only when following this procedure, it is ensured that all remaining pressure inside the body is eliminated.
2. Put body on a work bench with a soft cover (rubber mat).
3. Remove stud bolts (080) and separate side piece (020) from body.
4. Remove first ball seat ring (030).
5. Put hand lever is closed position. The ball can easily be pushed out of the body. Remove second ball seat ring (030).
6. Remove hand lever (070).
8. Remove lever stop (210).
9. Remove countersunk screws (120) and top cap (060), bush (061), belleville washers (110) and spacer (062).
10. Remove stem (040) pushing it down through the body. Care must be taken not to damage body liner.
11. Chevron packing (100) can easily be removed.

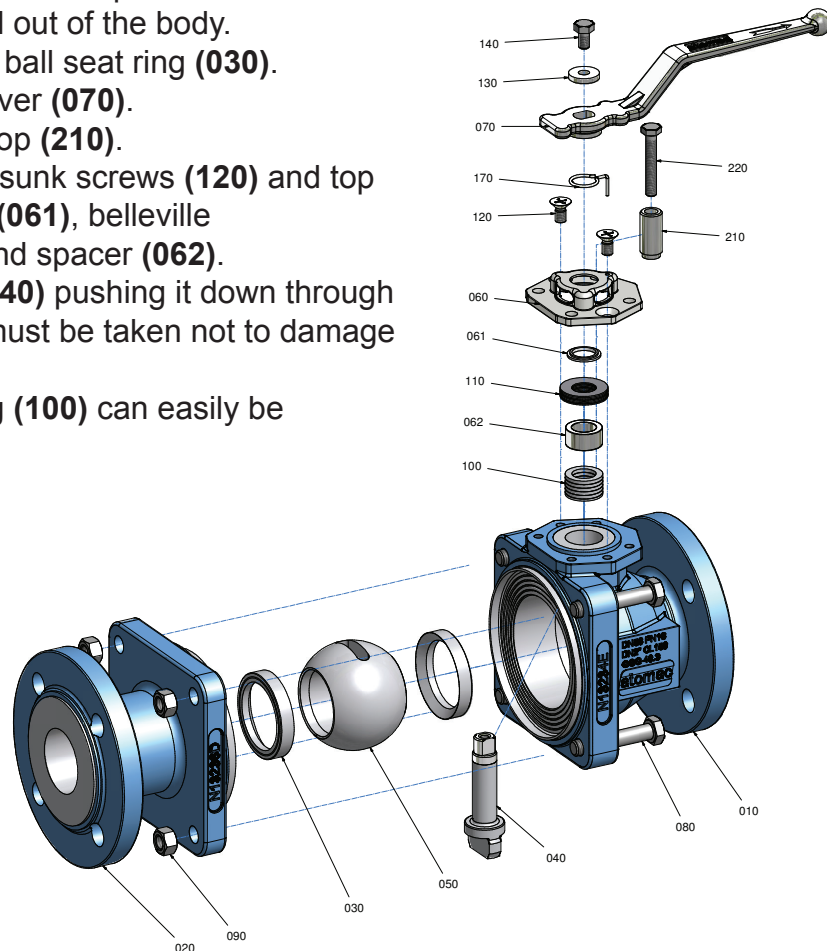

# Technical Manual

## AKH2.2 - recommended tightening torques\*

DN	tie rods (080/090)		connection flange	
	Nm	in.lbs	Nm	in.lbs
<b>015</b>	24	212,4	10	88
½"	25	221,3	8	71
<b>020</b>	24	212,4	18	160
¾"	25	221,3	11	97
<b>025</b>	26	230,1	25	221
1"	26	230,1	15	133
<b>032</b>	53	469,1	40	354
<b>040</b>	53	169,1	50	442
1½"	60	531	26	257
<b>050</b>	79	699,2	65	575
2"	88	778,8	60	531
<b>065</b>	145	1283,3	90	796
<b>080</b>	83	734,6	55	486
3"	86	761,1	100	885
<b>100</b>	134	1185,9	65	575
4"	143	1265,6	76	673

\* maximum value

## Manual Actuator

(worm gear)

The fully closed, waterproof actuator consists of a body with lid, worm gear, input shaft and hand wheel. For the correct adjustment of the ball position, there are two adjustable stops mounted in the body.

The gear is fully greased and does not need any further lubrication.

The actuator with hand wheel is mounted on a bracket with four stainless steel bolts. The on/off position is indicated through a pointer. The actuator is self-locked.

## Material specification

Designation	Material
Body	Gray Iron
Worm	Spheroidal Graphite Cast Iron
Input Shaft	AISI 410
Hand Wheel	Steel

**Material specification - AKH2.2  
 with manual actuator**

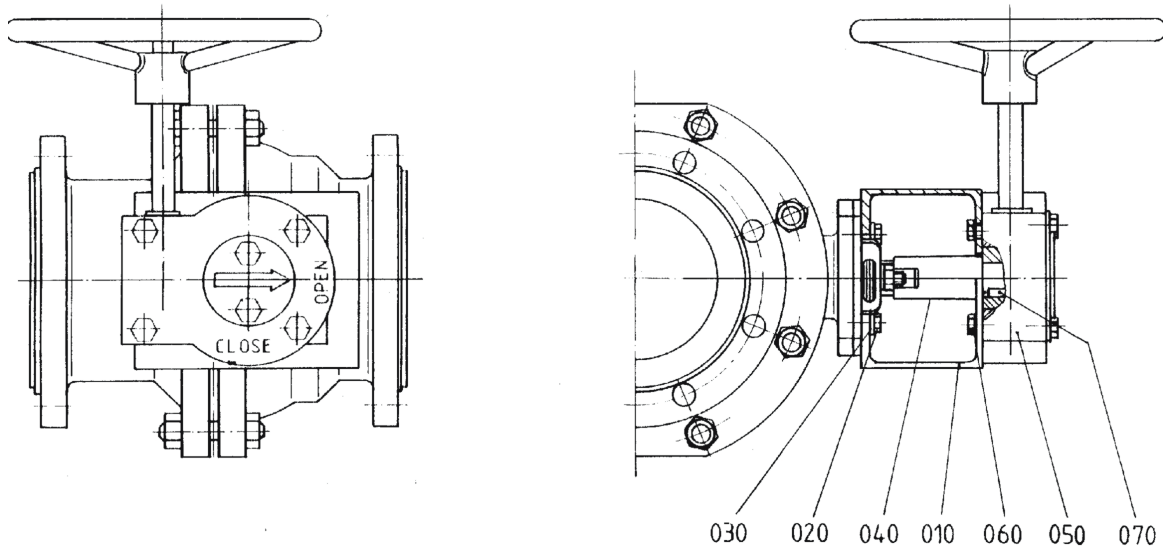

No.	Designation	Pieces	Material	Material-No. / DIN	ASTM / AISI
010	actuator bracket	1	steel	1.0037 / DIN EN 10025-2	A 283 B
020	hexagon bolt	4	Stainless steel	1.4301 / DIN EN 10088-3	A 193 B8
030	serrated lock washer	4	Stainless steel	1.4301 / DIN EN 10088-3	AISI 304
040	adapter	1	Stainless steel	1.4104 / DIN EN 10088-3	AISI 430 F
050	actuator	1			
060	hexagon bolt	4	Stainless steel	1.4301 / DIN EN 10088-3	A 193 B8
070	key	1	steel	1.0050 / DIN EN 10277-1	A 572 GR 50

## AKH2.2 - Actuator Sizing Torques

Packingmaterial: chevron PTFE or PTFE-graphite

- for clean and clear application

Size		0 bar Δ p Nm	0 psi Δ p in/lbs	10 bar Δ p Nm	150 psi Δ p in/lbs	19 bar Δ p Nm	275 psi Δ p in/lbs	MAST	
								Nm	in/lbs
015	1/2"	7	62	7	62	8	71	40	354
020	3/4"	7	62	7	62	8	71	40	354
025	1"	7	62	8	71	8	71	40	354
032	-	20	177	27	239	34	301	115	1018
040	1 1/2"	20	177	27	239	34	301	115	1018
050	2"	27	239	34	301	45	398	130	1151
065	-	51	451	73	646	93	426	420	3717
080	3"	59	522	85	752	108	956	420	3717
100	4"	79	699	119	1053	158	1398	420	3717

- for dry and slurry application

Size		0 bar Δ p Nm	0 psi Δ p in/lbs	10 bar Δ p Nm	150 psi Δ p in/lbs	19 bar Δ p Nm	275 psi Δ p in/lbs	MAST	
								Nm	in/lbs
015	1/2"	9	81	9	81	10	92	40	354
020	3/4"	9	81	9	81	10	92	40	354
025	1"	9	81	10	92	10	92	40	354
032	-	26	230	35	311	44	391	115	1018
040	1 1/2"	26	230	35	311	44	391	115	1018
050	2"	35	311	44	391	59	518	130	1151
065	-	66	587	95	840	121	1070	420	3717
080	3"	77	679	111	978	140	1243	420	3717
100	4"	103	909	155	1369	205	1818	420	3717

- Stated torques are sizing torques. No further safety factors are to be applied against these torques.
- The use of ceramic balls in lined valves will result in 15% higher sizing torques.
- The use of C-Balls or V-Balls does not result in change in sizing torques.
- Stated sizing torques are „Break-Open“ and „Re-Seating“ torques. Running torques are typically 35% below sizing torques.
- The stated „MAST“ value is the Maximum Allowable Stem Torque. Beyond this value permanent deformation / destruction of liner is to be expected.
- Please note the service conditions of the pressure- / vacuum-temperature-diagrams: register 1, page 13.

### AKH2.2 with actuator mounting

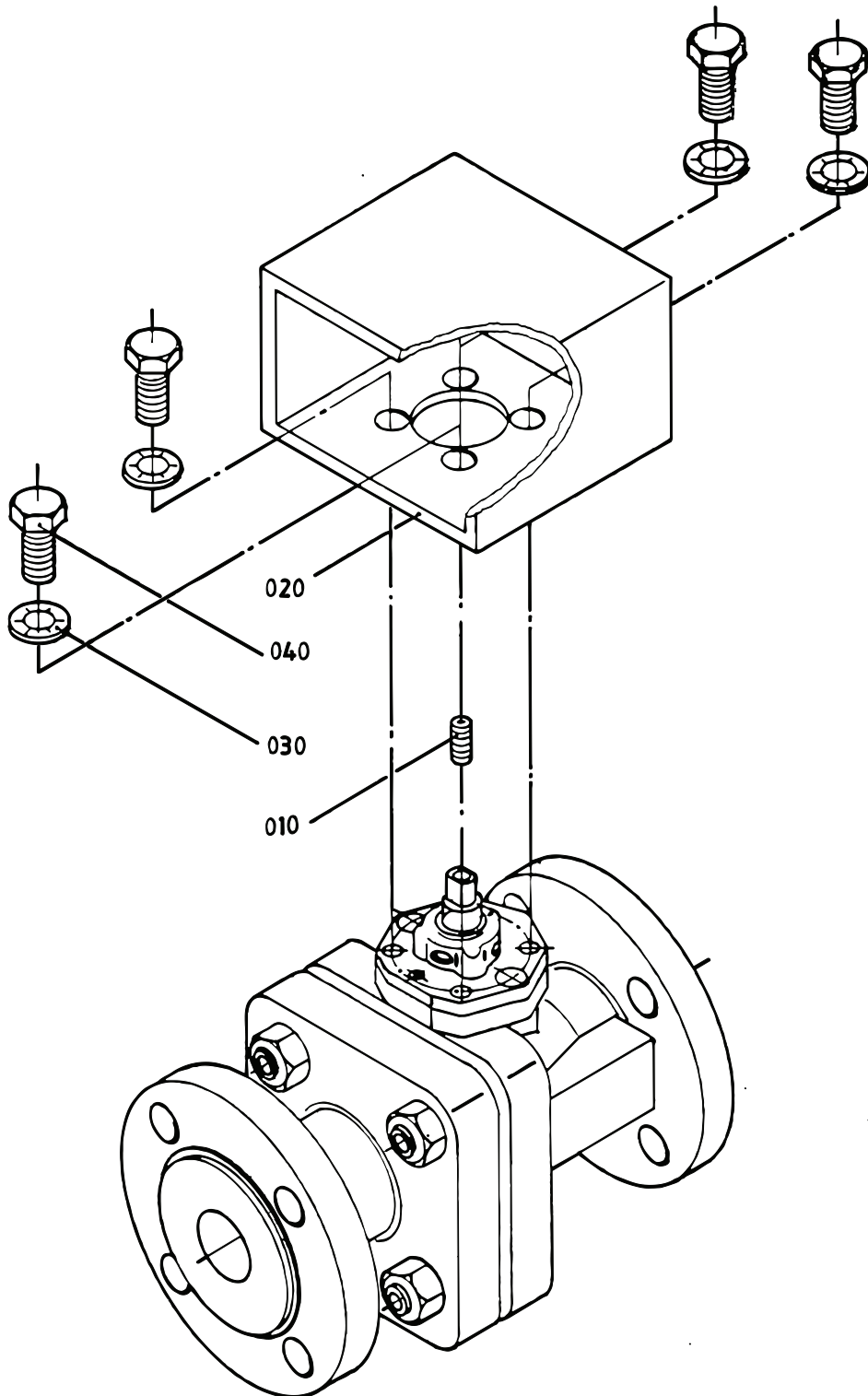

## Material specification - AKH2.2 with actuator mounting

No.	Designation	Pieces	Material	Material-No.	DIN	ASTM / AISI
010	threaded pin	1	stainless steel	1.4301	DIN EN 10088-3	A 193 B8
020	actuator bracket	1	steel (yellow chromated)	1.0037	DIN EN 10025-2	A 283-B
030	serrated lock washer	4	stainless steel	1.4301	DIN EN 10088-3	AISI 304
040	hexagon bolt	4	stainless steel	1.4301	DIN EN 10088-3	A 193 B8

*Item-No. 010 „threaded pin“ is used with sizes DN 015,020,025 and ½“, ¾“, 1“ only*

## AKH2.2 - Dimension sheet for actuator mounting acc. to NAMUR - recommendation

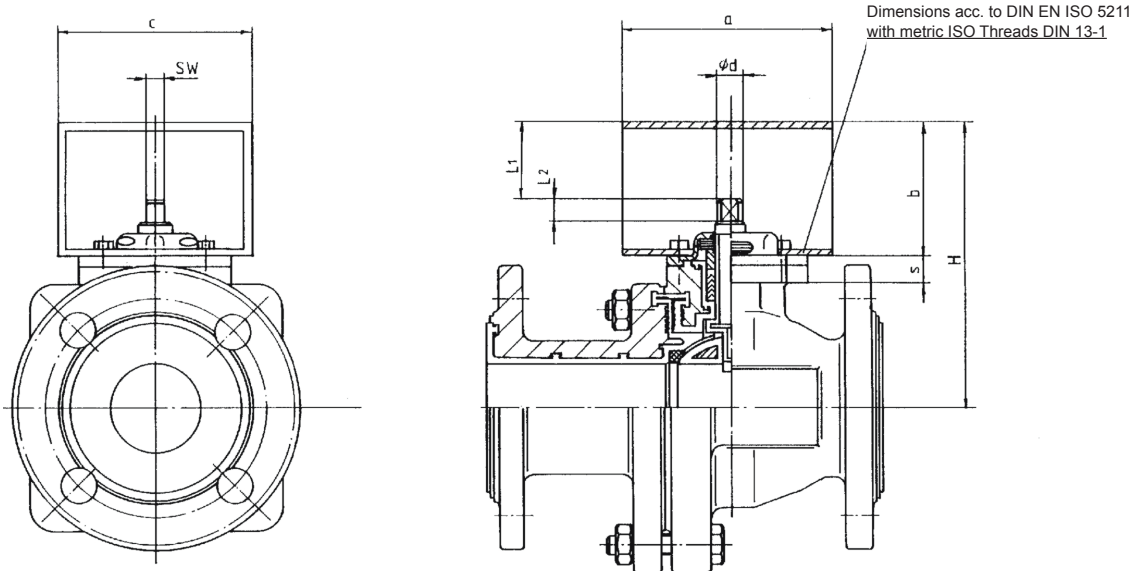

DIN	ANSI		H	a	b	c	SW	d	S	L1	L2	ISO 5211
015	½"	mm	112,5	75	60	100	8	10	12,5	39	7,5	F05
		inch	4,43	2,95	2,36	3,94	0,315	0,393	0,49	1,54	0,3	
020	¾"	mm	112,5	75	60	100	8	10	12,5	39	7,5	F05
		inch	4,43	2,95	2,36	3,94	0,315	0,393	0,49	1,54	0,3	
025	1"	mm	114	75	60	100	8	10	12,5	35,5	9,3	F05
		inch	4,49	2,95	2,36	3,94	0,315	0,393	0,49	1,4	0,37	
032	-	mm	135	100	60	100	12	16	16	31,5	12,5	F07
		inch	5,31	3,94	2,36	3,94	0,472	0,63	0,63	1,24	0,49	
040	1½"	mm	135	100	60	100	12	16	16	31,5	12,5	F07
		inch	5,31	3,94	2,36	3,94	0,472	0,63	0,63	1,24	0,49	
050	2"	mm	148	100	60	100	12	16	16	29	12,5	F07
		inch	5,83	3,94	2,36	3,94	0,472	0,63	0,63	1,14	0,49	
065	-	mm	207	135	80	140	16	22	20	41	15,5	F10
		inch	8,15	5,31	3,15	5,51	0,63	0,866	0,79	1,61	0,61	
080	3"	mm	214	135	80	140	16	22	20	41	15,5	F10
		inch	8,43	5,31	3,15	5,51	0,63	0,866	0,79	1,61	0,61	
100	4"	mm	229	135	80	140	16	22	20	41	15,5	F10
		inch	9,02	5,31	3,15	5,51	0,63	0,866	0,79	1,61	0,61	



## AKH2.2/DA

### Seat ring with pressure compensation grooves

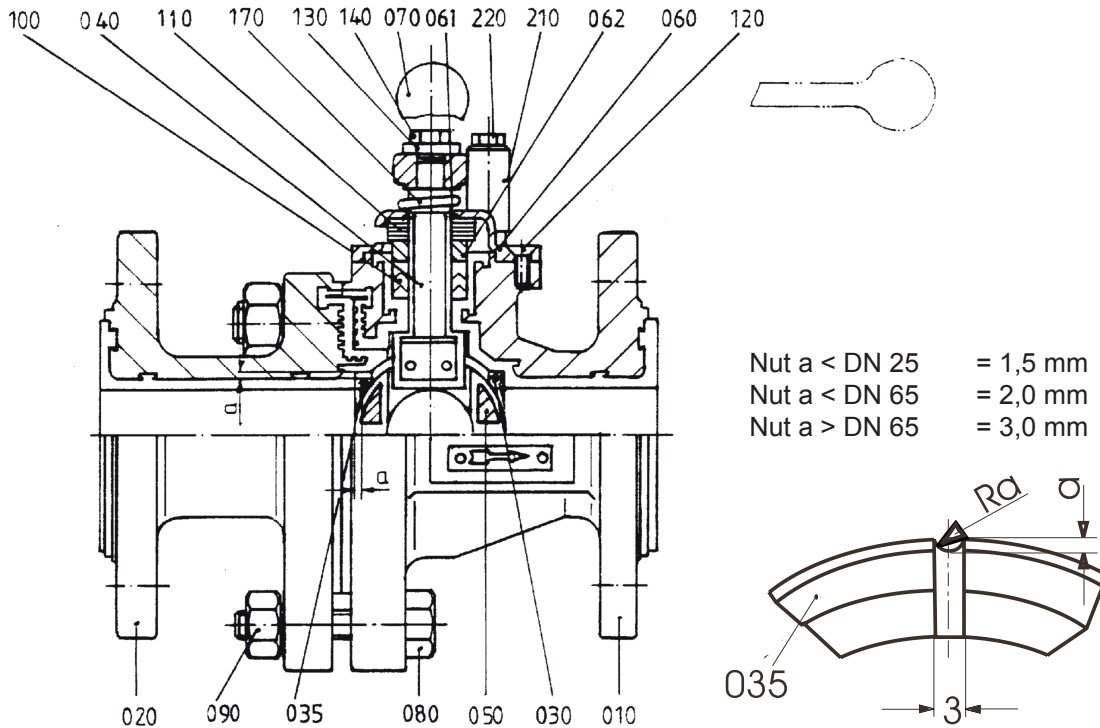

### Special Recleaning and Packing Procedures

#### 1. Recleaning

The ball valve should be thoroughly cleaned with a clean, dry, lint-free towel and blown off with dry nitrogen gas. This will assure that the valve is free from moisture, grease and other media before packing.

#### 2. Packing

Prior to packing, the ball valve should be jig welded in a PE-foil (0.2 mm thick). The bag contains desiccants acc. to DIN 55473, quantity acc. to DIN 55474 and a moisture indicator.

## Material specification AKH2.2/DA

No.	Designation	Pieces	Material	Material-No. / DIN	ASTM / AISI
010	body	1	ductile iron / PFA ductile iron / FEP °	EN-JS1049 (GGG-40.3) / DIN EN 1563	A 395
020	side piece	1	ductile iron / PFA ductile iron / FEP °	EN-JS1049 (GGG-40.3) / DIN EN 1563	A 395
030	seat ring	1	PTFE	pure - PTFE	
035	seat ring with pressure compensation grooves	1	PTFE	pure - PTFE	
040	stem	1	stainless steel / PFA Hastelloy C4 / PFA °°	1.4470 / DIN EN 10283 2.4610 / DIN 17744	A 890 CD3MN
050	ball				
	DN 15-25, 40-50, DN ½"- 2"	1	cast steel / PFA cast steel / FEP°	1.0619 / DIN EN 10213-2	ASTM A216 Grade WCB
	DN 32, 65 - 100, DN 3"- 4"	1	ductile iron / PFA ductile iron / FEP ° ceramic Al <sub>2</sub> O <sub>3</sub> *	EN-JS1049 (GGG-40.3) / DIN EN 1563	A 395
060	top cap	1	steel casting	1.4308 / DIN EN 10283	A 743 CF-8
061	bush	1	PTFE		
062	spacer	1	stainless steel	1.4104 / DIN EN 10088-3	A430 F
070	hand lever				
	DN 15 - 50, ½"- 2"	1	die cast metall (galvanizing)	ZP0410 / DIN EN 12844	
	DN 65 - 100, 3"- 4"	1	ductile iron (galvanized)	EN-GJS-50-7 (GGG-50)	
080	stud bolt				
	DN 15, 20, 32, DN ½"-4"	1 set	stainless steel	1.4301-K70 / DIN EN 10088-3	A 193 B8
	hexagon bolt				
	DN 25, 40, 50, 65, 80, 100	1 set	stainless steel	1.4301-K70 / DIN EN 10088-3	A 193 B8
090	hexagon nut	1 set	stainless steel	1.4301-K70 / DIN EN 10088-3	A 194 8
100	packing material (chevron)	1 set	PTFE ° PTFE-graphite °		
110	belleville washer	5	stainless steel	1.4310 / DIN EN 10270-3	AISI 301
120	countersunk screw	1 set	stainless steel	1.4301 / DIN EN 10088-3	A 193 B8
130	lock washer	1	stainless steel	1.4301 / DIN EN 10088-3	AISI 304
140	hexagon bolt	1	stainless steel	1.4301 / DIN EN 10088-3	A 193 B8
170	grounding device				
	DN 25, 50 - 100 DN 1", 2" - 4"	1	stainless steel	1.4310 / DIN EN 10270-3	AISI 301
	curved spring washer				
	DN 15, 20, 32, 40 DN ½", ¾", 1 ½"	1	stainless steel	1.4301 / DIN EN 10088-3	A 193 B8
210	stop				
	DN 15 - 100, ½" - 4"	1	steel (galvanizing)	1.0037 / DIN EN 10025-2	A 283 B
220	hexagon bolt	1	stainless steel	1.4301 / DIN EN 10088-3	A 193 B8

\* ceramic ball on request  
 °° Hastelloy stem on request  
 ° optional

## Assembly Instructions AKH2.2/DA

*The general installation and maintenance instructions must be observed.*  
**Attention**, please take care of the right direction of indicator while assembly.

1. Insert stem (040) from inside of body in such a way that the flat side is parallel to body longitudinal axis.
2. Insert chevron packing (100) and spacer (062).
3. Install belleville washers (110) on spacer (in alternating layers).
4. Install top cap (060) and bush (061) on valve body using countersunk screws (120).
5. Install grounding device (170) also on valves with actuator.
6. Install hand lever (070) on to stem (040) and tighten it using lock washer (130) and hexgon nut (140).
7. Insert first ball seat ring (030) into body (010).
8. Insert ball (050) to valve stem by pushing the ball in a downward motion through valve body.
9. Turn hand lever 90° off longitudinal axis of body.
10. Install ball seat ring with pressure compensation groovers (035) on to ball (050).
11. Install side piece (020) on to body (010).
12. Install hexagon bolts (080) or respectively stud bolts and hexagon nuts (090) and tighten by crisscross method to recommended torques.
13. Install lever stop (210) using hexagon bolt (220).

*Disassembly instruction see register 12, page 9*

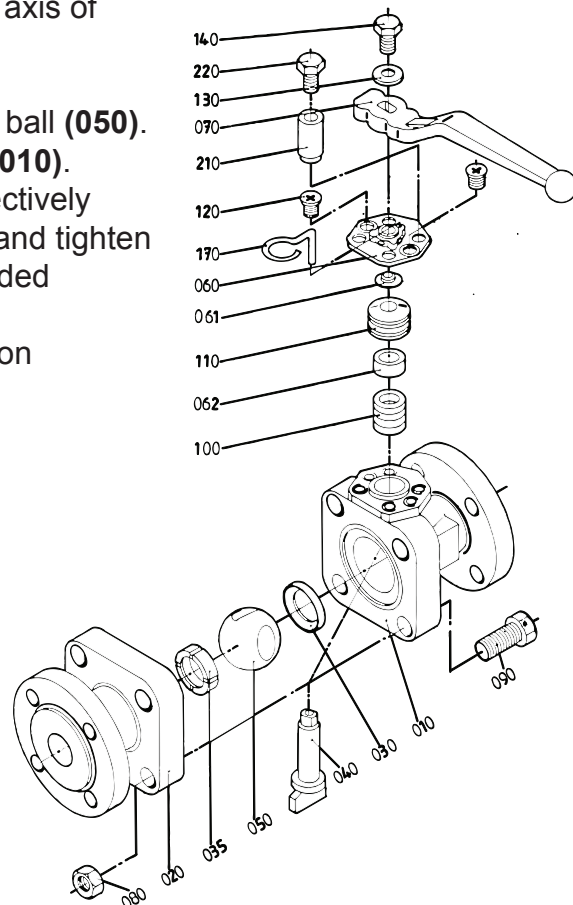

## AKH2.2 - $K_v$ DATA and $C_v$ Data (DIN EN 60534-2-3)

DIN	ANSI	$K_v$ m <sup>3</sup> /h	$C_v$ gal/min
015	1/2"	16,9	19,6
020	3/4"	24,4	28,4
025	1"	38,6	44,9
032	-	68,4	79,5
040	1 1/2"	121,4	141,1
050	2"	199,9	232,3
065	-	329,3	382,7
080	3"	525,8	611,1
100	4"	940,2	1092,8

## Optional C-ball in ball valves

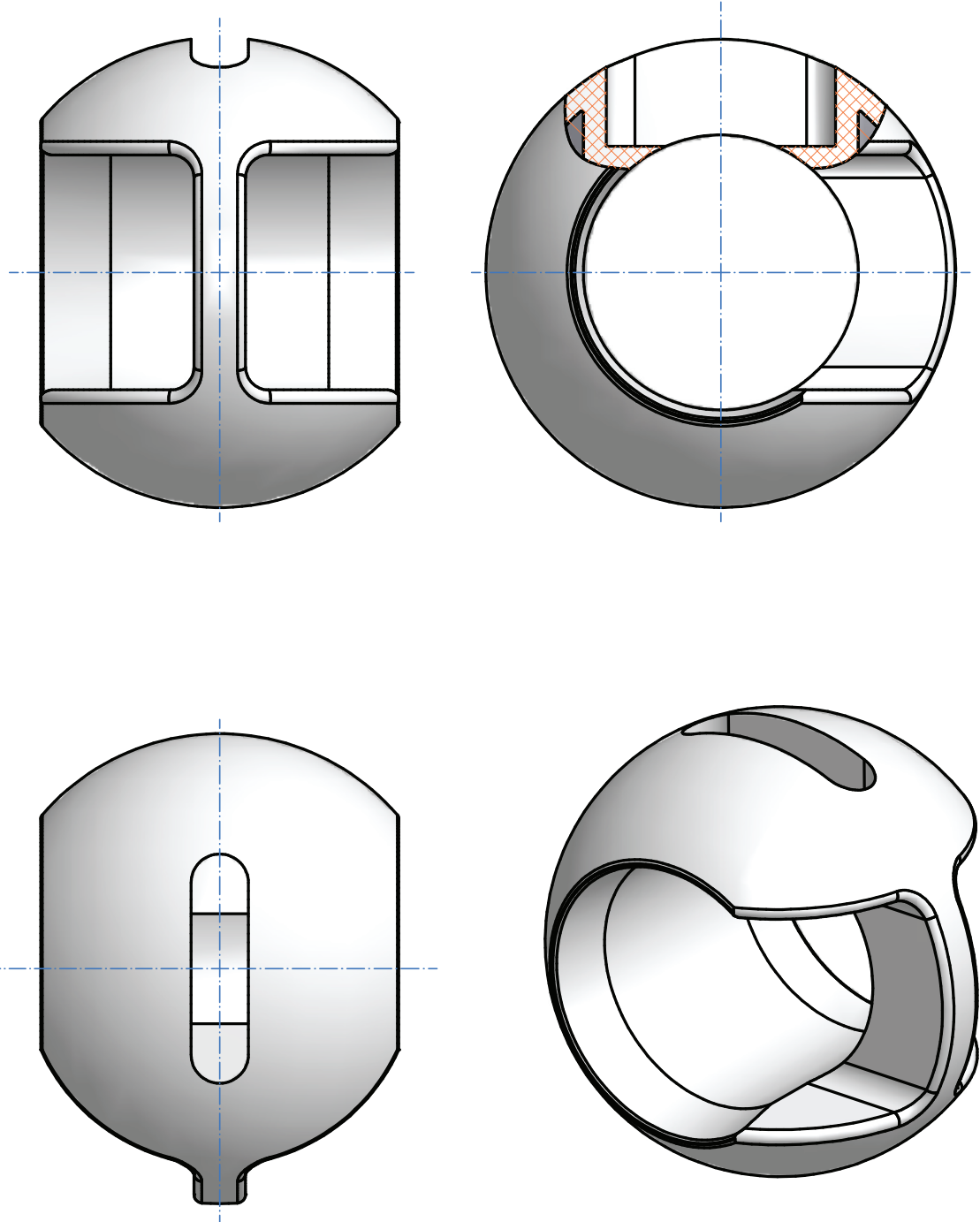

For details please contact our Sales office at Ahaus, Germany

### Optional V-ball in ball valves

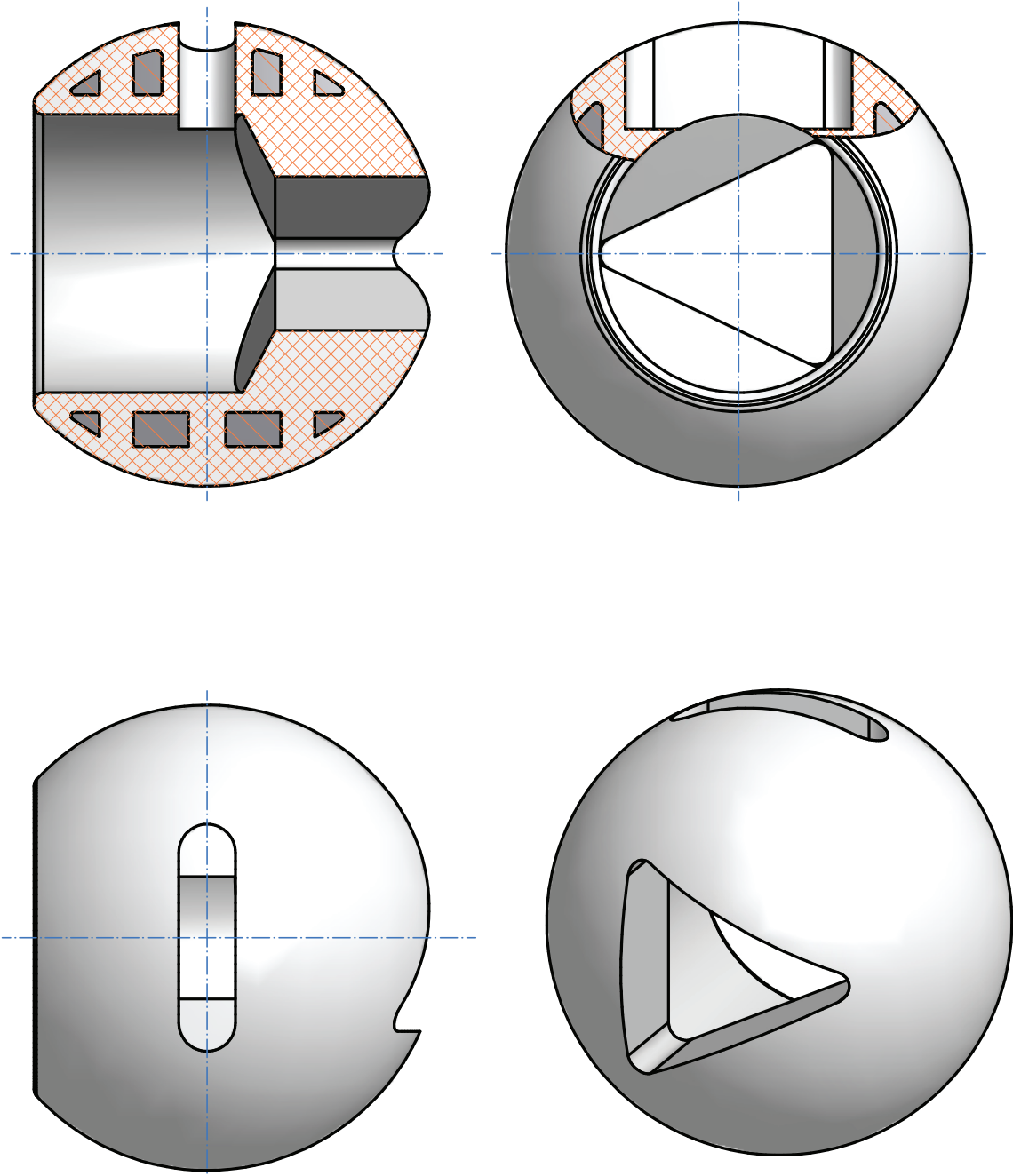

For details please contact our Sales office at Ahaus, Germany