

Drystar GV400 & EH2600/4200 Packages

Edwards has pioneered the use of dry vacuum pumps in some of the most critical and demanding applications. By combining the well proven Edwards claw mechanism pumps with a hydrokinetic drive booster; the Edwards Drystar GV400/EH2600 and GV400/EH4200 series provides benefits in economy, performance and compactness, with a clean robust pumping alternative to oil-sealed vacuum pumping systems.

The Drystar systems non-contacting mechanism reduces wear and maintenance for higher up-time and provides for faster pump-down performance. The Drystar packages are effective and cost efficient, and offer the ability to handle dust and water vapour without the risk of process contamination, loss of performance and maintenance issues associated with oil-sealed vacuum pumping systems.



Features and benefits

- Reduced maintenance
 - Eliminate regular oil changes, non-contacting mechanism eliminates wear
 - Extended pump life on dusty applications - no dust build-up in oil, leading to high wear
 - No need for pressure switching and bypass arrangements
- Improved process
 - No oil contamination of process - improved product quality
 - Consistent vacuum performance - no water contamination of seal oil which reduces pump performance and extends pump down time
 - Hydrokinetic drive booster gives faster pump down performance
- Added environmental and safety standards
 - Eliminates exhaust oil mist, oil handling and disposal costs
 - Reduces handling of contaminated pump oil, spillages and exhaust oil vapour around the pump area
 - Reduced footprint for better space utilisation
 - Global aftermarket support for improved uptime and support

Applications

You can be assured Edwards has the application expertise and the Drystar pump or integrated system solution to meet your needs.

- Metallurgy
 - VM, VAR, EB welding
- Heat treatment
 - Low pressure nitriding, sintering, brazing
- Coating
 - Glass coating, roll coating, HDD drive manufacturing, optical filters, decorative coatings
- Chemical Vapour Deposition
- Load lock
- Transformer and other drying
- Large chamber evacuation



Standard options & accessories

Kit	When to use
Standard purge kit	Clean, inert, non-cycling applications
Atmospheric seal purge	
Seal purge	
Nitrogen/CDA seal purge	Cycling and dusty applications
Full purge	Cycling and dusty applications with high vapour loads/ flammables or corrosives
Nitrogen/CDA seal purge, gas ballast and exhaust purge	
Direct water cooling	Standard use
GV pump indirect cooling (with solenoid option)	Poor water quality or elevated temperature operation
Silencer (stainless steel drainable or mild steel cleanable)	Dusty applications
Filtration	
Electrical Controls	High oxygen concentration pumped gases, corrosive gases
Fomblinised combinations	

Technical data

GV400 dry pump and EH2600/4200 booster:

		GV400 dry pump	EH2600/4200 booster	GV400 dry pump	EH2600/4200 booster
		50 Hz		60 Hz	
Peak pump speed	m ³ /hr (cfm)	2200 (1300) with EH2600 3200 (1900) with EH4200		2500 (1500) with EH2600 3800 (2300) with EH4200	
Ultimate	mbar (Torr)	9 x 10 ⁻³ (7 x 10 ⁻³)		6 x 10 ⁻³ (5 x 10 ⁻³)	
Motor size	kW	18.5	11	22	11
Power at vacuum	kW	7	2	8	2
Water flow rate	litres/hr max	240	360	240	360
Seal purge flow rate	litres/min	25	N/A	25	N/A
Noise	dB(A)	<82	<83	<82	<83
Mass	kg	714	345 (EH2600) 380 (EH4200)	714	345 (EH2600) 380 (EH4200)

Performance

GV400 + EH2600 Booster 50-60Hz

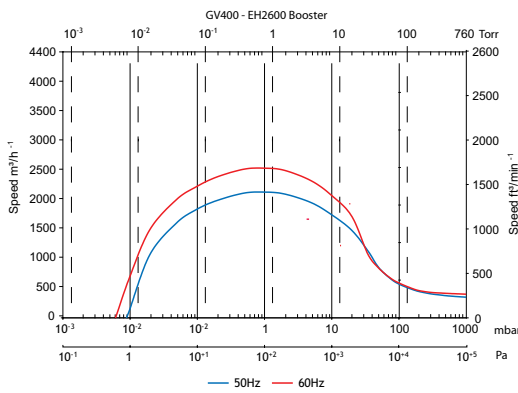

GV400 + EH4200 Booster 50-60Hz

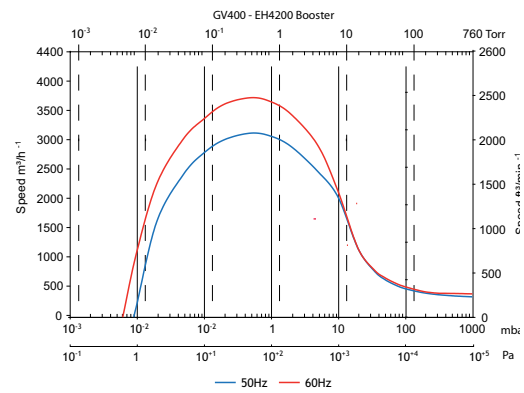

Pump down GV400 + EH Booster 50 Hz

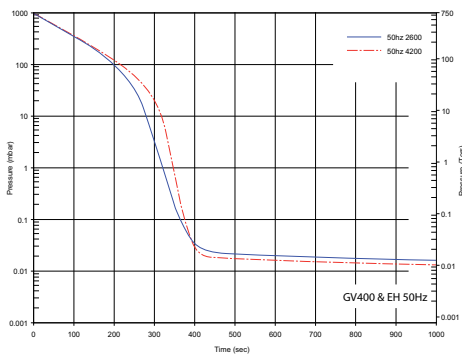

Pump down GV400 + EH Booster 60 Hz

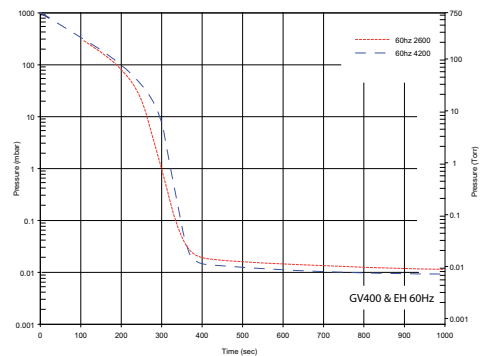

Pumpdown times - 3m³ chamber made of stainless steel and nitrile seals. Area factor of 3.

Dimensions (mm)

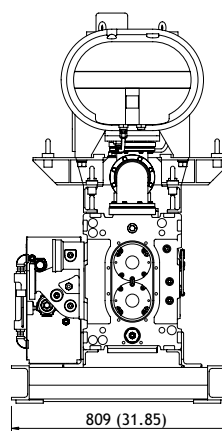
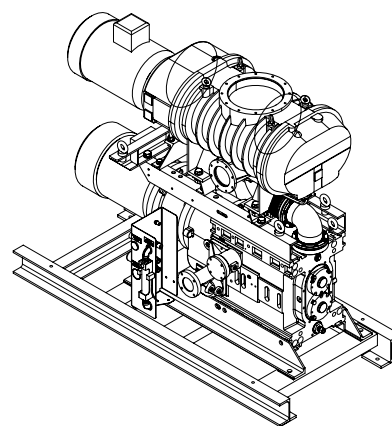
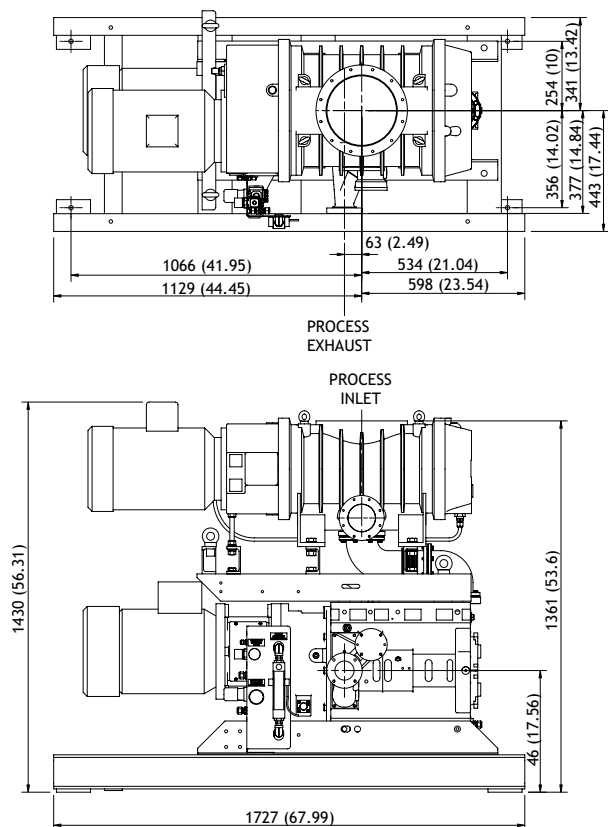

Standard packages	50 Hz, 400 V	60 Hz, 230/460 V
GV400 + EH2600, direct cooling, nitrogen/CDA shaft seal purge, MS silencer	GE7786551A	GE7786552A
GV400 + EH2600, direct cooling, full purge package, MS silencer	GE7786C51A	GE7786C52A
GV400 + EH4200, direct cooling, nitrogen/CDA shaft seal purge, MS silencer	GE7986551A	GE7986552A
GV400 + EH4200, direct cooling, full purge package, MS silencer	GE7986C51A	GE7986C52A

Global contacts

EUROPE

UK Crawley +44 1293 528844
 UK (local rate) 08459 212223
 Belgium Brussels +32 2 300 0730
 France Paris +33 1 4121 1256
 Germany Munich 0800 000 1456
 Italy Milan +39 02 48 4471

USA

Niagara (toll free) +1 800 848 9800
BRAZIL
 Sao Paulo +55 11 3952 5000
ISRAEL
 Qiryat-Gat +972 8 681 0633

ASIA PACIFIC

China (toll free) +86 400 111 9618
 India, Pune +91 20 4075 2222
 Japan, Yachiyo +81 47 458 8831
 Korea, Bundang +82 31 716 7070
 Singapore +65 6546 8408
 Taiwan R.O.C. Jhunan Town +886 3758 1000