

EM OIL SEALED ROTARY PUMPS

MEDIUM AND LARGE PUMPS



WWW.EDWARDSVACUUM.COM

INNOVATIVE PRODUCTS

GLOBAL STRENGTH

LOCAL SUPPORT

VACUUM EXPERTISE

PROVEN PERFORMANCE THAT SETS THE INDUSTRY STANDARDS

Edwards EM series two stage oil sealed rotary vane vacuum pumps are renowned for their high ultimate vacuum, rapid pumping speeds, quiet operation and ability to handle water vapour.

A comprehensive range of accessories is available to allow their use on the widest variety of vacuum applications.

The standard "Industrial" models are suitable for most duties and are safe to handle non-flammable gases and vapours within the normal operating parameters of the pump. Flammable gases and vapors may also be pumped, provided they are outside the flammable range. Please consult Edwards for advice.

EM primary pumps may be supplied for use with PFPE oil. This enables them to be used in harsh (corrosive) processes, or where Oxygen will be present in high concentrations.

EM primary pumps (hydrocarbon oil only) may be supplied with ATEX classification either as part of a pump system or stand-alone. Please consult Edwards for more details.

The EM range of direct drive rotary vane pumps are inherently compact and vibration free, and with their finger-proof fan and coupling housings they offer excellent operator protection.

Edwards rugged two stage mechanical oil sealed pumps are available in sizes from 40 to 275 m³h⁻¹ 50Hz (30 to 180 ft³min⁻¹ 60Hz). Smaller models from 0.7 to 28 m³h⁻¹ 50Hz (0.5 to 19 ft³min⁻¹ 60Hz) are also available, ask Edwards for more details.

They feature:

- *Advanced pressurised oil circuit to give effective lubrication even under high gas loads*
- *When the pump is switched off, the spring loaded distributor valve provides oil and air suck-back protection*
- *Gas Ballast control to assist in handling high water vapour loads*
- *Industrial roller bearings on drive shaft for ultimate reliability and long, trouble free life*
- *Full height oil sight glass for easy checking of oil level and condition*
- *Easy change oil filter, with oil filter condition gauge on larger models*
- *Central inlet port to allow easy mounting of mechanical booster pump if required*
- *Easy to maintain, with convenient service kits and international customer support.*
- *A wide range of accessories to match your application needs*
- *The pumps and accessories can be supplied either as individual components or as fully systemised, factory-tested combinations.*

Typical Applications:

- *Vacuum metallurgy processes*
- *Thin film coating technologies*
- *Pharmaceutical freeze drying*
- *Refrigeration and air conditioning system evacuation, drying, and backfilling*
- *Transformer and cable drying and impregnation, insulating oil treatment plant*
- *Lamp manufacture*
- *Cryogenic vessel evacuation*
- *Vacuum drying and distillation in chemical industries*
- *Semiconductor device manufacture*
- *Backing pump for high vacuum applications*



E2M40 TWO STAGE

42.5 m³h⁻¹, 25 ft³min⁻¹, 700 l min⁻¹

ORDERING INFORMATION

PRODUCT DESCRIPTION	ORDERING NUMBER
EM40 Industrial	
E2M40 220-240 V or 380-415 V, 3-ph, 50 Hz	A36401935
E2M40 208-230 V or 460 V, 3-ph, 60 Hz	A36402982
EM40 PFPE*	
E2M40FX 220-240 V or 380-415 V, 3-ph, 50 Hz	A36411935
E2M40FX 208-230 V or 460 V, 3-ph, 60 Hz	A36412982
EM40 ATEX**	
E2M40T4 400 V, 3-ph, 50 Hz	A36418993

Ultragrade 70 oil, NW40 "O" ring and centering ring, ISO 40 "C" clamp, bolts, washers, 28 mm external diameter coupling tube and compression sleeve for outlet, ISO 25 "C" clamp, bolts and washers supplied with each pump

* No oil supplied

** ATEX EM pumps may be supplied with ATEX classification either as part of a pump system or stand-alone, on application. Please consult Edwards.

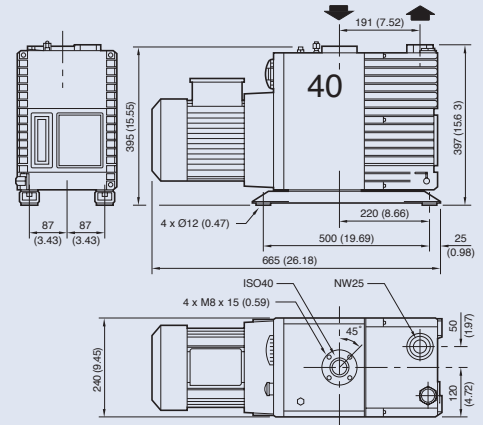

E2M80 TWO STAGE

80 m³h⁻¹, 47 ft³min⁻¹, 1333 l min⁻¹

ORDERING INFORMATION

PRODUCT DESCRIPTION	ORDERING NUMBER
EM80 Industrial	
E2M80 220-240 V or 380-415 V, 3-ph, 50 Hz	A36501935
E2M80 208-230 V or 460 V, 3-ph, 60 Hz	A36502982
EM80 PFPE*	
E2M80FX 220-240 V or 380-415 V, 3-ph, 50 Hz	A36511935
E2M80FX 208-230 V or 460 V, 3-ph, 60 Hz	A36512982
EM80 ATEX**	
E2M80T4 400 V, 3-ph, 50 Hz	A36518993

Ultragrade 70 oil, NW40 "O" ring and centering ring, ISO 40 "C" clamp, bolts, washers, 28 mm external diameter coupling tube and compression sleeve for outlet, ISO 25 "C" clamp, bolts and washers supplied with each pump

* No oil supplied

** ATEX EM pumps may be supplied with ATEX classification either as part of a pump system or stand-alone, on application. Please consult Edwards.

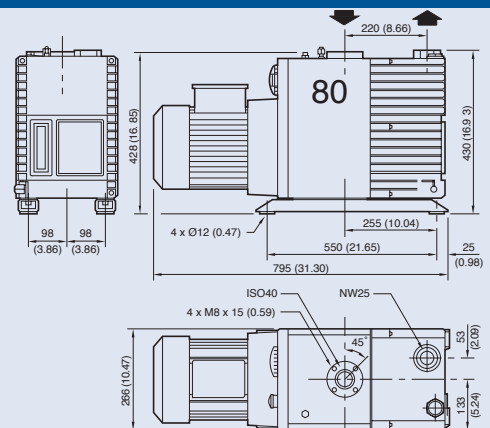

DATA SUMMARY EM OIL SEALED ROTARY VANE PUMPS

Pump	E2M40	E2M80	E2M175	E2M275
Displacement 50 Hz 60 Hz	42.5 m ³ h ⁻¹ / 25 ft ³ min ⁻¹ 50.5 m ³ h ⁻¹ / 29.7 ft ³ min ⁻¹	80 m ³ h ⁻¹ / 47.1 ft ³ min ⁻¹ 96 m ³ h ⁻¹ / 56.5 ft ³ min ⁻¹	178 m ³ h ⁻¹ / 105 ft ³ min ⁻¹ 214 m ³ h ⁻¹ / 126 ft ³ min ⁻¹	292 m ³ h ⁻¹ / 172 ft ³ min ⁻¹ 350 m ³ h ⁻¹ / 206 ft ³ min ⁻¹
Speed 50 Hz (Pneurop) 60 Hz	37 m ³ h ⁻¹ / 21.8 ft ³ min ⁻¹ 44 m ³ h ⁻¹ / 25.9 ft ³ min ⁻¹	74 m ³ h ⁻¹ / 43.6 ft ³ min ⁻¹ 90 m ³ h ⁻¹ / 53 ft ³ min ⁻¹	160 m ³ h ⁻¹ / 94 ft ³ min ⁻¹ 196 m ³ h ⁻¹ / 115 ft ³ min ⁻¹	255 m ³ h ⁻¹ / 150 ft ³ min ⁻¹ 306 m ³ h ⁻¹ / 180 ft ³ min ⁻¹
Number of stages	2			
Ultimate vacuum (total pressure) without gas ballast mbar / Torr with gas ballast mbar / Torr	1.0 x 10 ⁻³ / 7.7 x 10 ⁻⁴ 7.0 x 10 ⁻³ / 5.4 x 10 ⁻³	1.0 x 10 ⁻³ / 7.7 x 10 ⁻⁴ 7.0 x 10 ⁻³ / 5.4 x 10 ⁻³	1.0 x 10 ⁻³ / 7.7 x 10 ⁻⁴ 5.0 x 10 ⁻³ / 3.75 x 10 ⁻³	1.0 x 10 ⁻³ / 7.7 x 10 ⁻⁴ 5.0 x 10 ⁻³ / 3.8 x 10 ⁻³
Inlet connection ISO40	ISO40		ISO 63 blank flange with seal	
Outlet connection	25 mm flange suitable for NW25		ISO 40 flange center tapped 1½ inch BSP	
Maximum permitted pressure at outlet	0.5 bar gauge			
Maximum inlet pressure for water vapour	7 mbar / 5.3 Torr	5 mbar / 3.8 Torr	20 mbar / 15 Torr	12 mbar / 9 Torr
Maximum water vapor pumping rate	0.2 kg h ⁻¹ / 0.4 lb h ⁻¹	0.3 kg h ⁻¹ / 0.7 lb h ⁻¹	2.4 kg h ⁻¹ / 5.3 lb h ⁻¹	2.3 kg h ⁻¹ / 5.1 lb h ⁻¹
Weight	72 kg / 159 lb	105 kg / 231 lb	200 kg / 441 lb	225 kg / 495 lb
Motor protection rating	IP 44 or IP 54	IP 44 or IP 54	IP 44	
Motor power 50 Hz 60 Hz	1.1 kW / 1.5 hp 1.5 kW / 2 hp	2.2 kW / 3 hp 3 kW / 4 hp	5.5 kW / 7.5 hp 6.5 kW / 8.5 hp	7.5 kW / 10 hp 8.5 kW / 11 hp
Standard oil capacity maximum minimum	4.07 liter / 4.3 qt 2.2 liter / 2.3 qt	6.3 liter / 6.7 qt 4.0 liter / 4.2 qt	25 liter / 26 qt 16 liter / 17 qt	28 liter / 29.5 qt 19 liter / 20 qt
PFPE oil capacity maximum minimum	3.5 liter / 3.2 qt 1.32 liter / 1.6 qt	4.01 liter / 4.2 qt 2.19 liter / 2.3 qt	18 liter / 19 qt 6.5 liter / 6.9 qt	18 liter / 19 qt 7 liter / 7 qt
Recommended oil	Ultragrade 70			
Noise level	65 dB(A)	70 dB(A)	75 dB(A)	

SYSTEMS CAPABILITY

Our comprehensive range of mechanical booster and oil sealed rotary pumps forms the basis for the manufacture of factory-tested combination pumping systems. These systems have displacements from 310 to 4140 m³h⁻¹ 50Hz (220 to 2935 ft³min⁻¹ 60Hz).

Edwards rotary pumps are specifically designed with centrally placed inlets, so that the mechanical booster pump can be mounted on the backing pump with minimum overhang, to give a very compact arrangement.

The pannier-style outlet accessories together with the absence of gas-lines and pressure switches contribute further to the neat, compact designs.

The combination systems can be supplied complete with on-line starters for each pump. These are configured so that the mechanical booster pump cannot be switched on before the rotary pump, and so that both pumps are switched off together.



PUMP ACCESSORIES

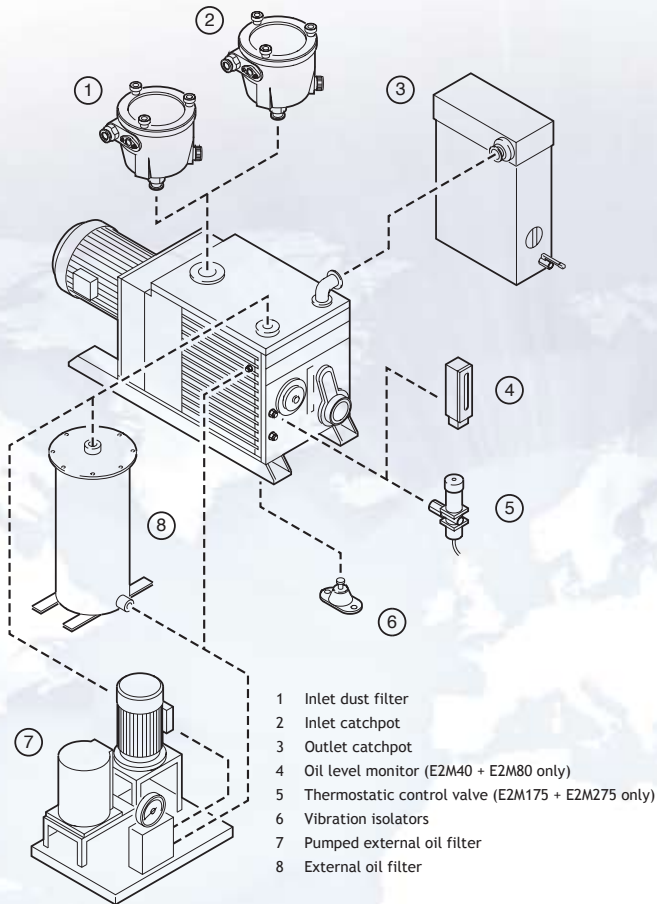

Industrial oil sealed pumps are used in a wide variety of applications and produce reliable vacuum for many processes. To optimize the installation and to prolong pump life, Edwards offers a range of accessories for our large oil-sealed pumps. Our pumps and accessories are designed to ensure that accessories are easy to install.

We offer inlet and exhaust traps and filters, together with external oil filtration and oil pressure monitoring, pump temperature control and vibration isolators.

Spares

A range of spares including flanges, cords, tubings, oils, fluids, sealants and greases are available to ensure the smooth running of your pump.

See Edwards catalog for further details.

GLOBAL CUSTOMER SUPPORT:

- Service spares, kits and tooling
- On-site support
- Product repair and overhaul
- Product exchange
- Upgrades
- Refurbished product sales
- Service contracts and agreements
- Operation, maintenance and service training

GLOBAL CONTACTS:

AUSTRALIA

Australia +61 4 0199 1193

BELGIUM

Brussels +32 2 363 0030

BRAZIL

Sao Paulo +55 11 3952 5000

CHINA

Shanghai +86 21 5866 9618

FRANCE

Paris +33 1 47 98 24 01

GERMANY

Munich 0800 000 1456

INDIA

Mumbai +91 22 2565 1177

ISRAEL

Kiryat-Gat +972 8 681 0633

ITALY

Milan +39 02 48 4471

JAPAN

Yachiyo +81 47 458 8831

KOREA

Bundang +82 31 716 7070

SINGAPORE

Singapore +65 6546 8408

TAIWAN R.O.C.

Toufen Town +886 37 611422

UNITED KINGDOM

Crawley +44 1293 528844

UK Only 08459 212223

UNITED STATES

MA +1 978 658 5410

US Only +1 800 848 9800



WWW.EDWARDSVACUUM.COM